

OPTIMUM 8 - OPTIMUM 1931 E

Operator's manual

OPTIMUM 8 - OPTIMUM 1931 E

4000415480

E 11 15

US / GB



A

FOREWORD

- 1 - User responsibility 8**
 - 1.1- Owner's responsibility 8
 - 1.2- Employer's responsibility 8
 - 1.3- Trainer's responsibility 8
 - 1.4- Operator's responsibility 8
- 2 - Safety 9**
 - 2.1- Safety instructions 9
 - 2.1.1 - Misuse Hazards 9
 - 2.1.2 - Falling Hazards 10
 - 2.1.3 - Overturning / Tip-over Hazards 11
 - 2.1.4 - Electrocution Hazards 14
 - 2.1.5 - Explosion / Fire Hazards 15
 - 2.1.6 - Crushing / Collision Hazards 16
 - 2.1.7 - Uncontrolled movement Hazards 17
- 3 - Safety inquiries 18**
- 4 - Incident notification 18**
- 5 - Compliance 18**
 - 5.1- Product information 18
 - 5.1.1 - Change of Ownership Notification 18
 - 5.1.2 - Owner information update form 19
 - 5.2- Product specifications 20

B

FAMILIARIZATION

- 1 - General safety 21**
 - 1.1- Intended use 21
 - 1.2- Decal content 22
 - 1.3- Symbols and colors 23
 - 1.4- Level of severity 23
 - 1.5- Symbols legend and definitions 24
- 2 - Models description 25**
- 3 - Primary machine components 26**
 - 3.1- Layout 26
 - 3.2- Maintenance support 27
 - 3.3- Ground control box 28
 - 3.3.1 - Layout 28
 - 3.3.2 - HAULOTTE Activ'Screen 29
 - 3.3.2.1 - LCD screen 30
 - 3.4- Platform control box 34
 - 3.4.1 - Layout 34
- 4 - Performance Specifications 36**
 - 4.1- Technical characteristics 36
 - 4.2- Working area / Range of motion 38
- 5 - Decals and markings locations 40**

CONTENTS



C

PRE-OPERATION INSPECTION

- 1 - Recommendations 53**
- 2 - Working area assessment 53**
- 3 - Inspection and Functional test 54**
 - 3.1- Daily inspection 54
- 4 - Safety functional checks 58**
 - 4.1- E-Stop button check 58
 - 4.2- Activation of controls 58
 - 4.3- Fault detector 59
 - 4.3.1 - Buzzers test 59
 - 4.4- Overload sensing system (if fitted) 59
 - 4.5- Slope warning device 60
 - 4.6- Travel speed limitation 60
 - 4.7- Electronic variable speed drive 60
 - 4.8- Operating temperature (For Russia and the Ukraine only) 61
 - 4.9- Machine braking 61
 - 4.10- Wheel motor brake release 61
 - 4.11- Pothole protection system 61
 - 4.12- On-board charger 62
 - 4.12.1 - Battery charge level 62
 - 4.13- Anti-crush system when lowering 62

D

OPERATION INSTRUCTIONS

- 1 - Operation. 63**
 - 1.1- Introduction 63
 - 1.2- Operation from the ground control box 63
 - 1.3- Operation from the platform control box 64
- 2 - Ground control box 66**
 - 2.1- To start and stop the machine 66
 - 2.2- Movement control 66
 - 2.3- Additional controls from the ground control box 67
- 3 - Platform control box 68**
 - 3.1- To start and stop the machine 68
 - 3.2- Drive and steer control 68
 - 3.3- Movement control 69
- 4 - Emergency procedure 70**
 - 4.1- In case of power loss 70
 - 4.2- To rescue operator in platform 70
- 5 - Transportation 71**
 - 5.1- Putting in transport position 71
 - 5.2- Machine layout 72
 - 5.3- Unloading 72
 - 5.4- Towing 73
 - 5.4.1 - Free wheel mode 74
 - 5.5- Storage 75
 - 5.6- Loading by ramp 75
 - 5.7- Unloading by ramp 75
 - 5.8- Lifting operation 76
 - 5.9- Loading and unloading with forklift 77



6 - Cold Weather Recommendations	78
6.1- Hydraulic oil	78
7 - Battery care and maintenance	79
7.1- Battery charging	79

E

GENERAL SPECIFICATIONS

1 - Machine dimensions	83
2 - Major component masses	84
3 - Acoustics and vibrations	84
4 - Wheel/Tire assembly	85
4.1- Technical specifications	85
4.2- Inspection and maintenance	85
5 - Options	87
5.1- Plumber's kit	87
5.1.1 - Description	87
5.1.2 - Characteristics	87
5.1.3 - Safety precautions	87
5.1.4 - Pre-operation inspection	88
5.1.5 - Operation	88
5.1.6 - Disassembly - Assembly	89
5.1.7 - Specific decals	90

F

MAINTENANCE

1 - General	91
2 - Maintenance Schedule	92
3 - Inspection program	93
3.1- General program	93
3.2- Daily inspection	94
3.3- Periodic inspection	94
3.4- Reinforced inspection	94
3.5- Major inspection	95
4 - Repairs and adjustments	95

CONTENTS



G

OTHER INFORMATION

- 1 - Warranty disclosure 97**
 - 1.1 - After Sales Service 97
 - 1.2 - Manufacturer's warranty 97
 - 1.2.1 - Warranty acceptance 97
 - 1.2.2 - Warranty period 97
 - 1.2.3 - Procedure conditions 97
 - 1.2.4 - Conditions of warranty 98
- 2 - Subsidiary contact information 100**



A - Foreword

You have just purchased a HAULOTTE® product and we would like to thank you for your business.

The Aerial Work Platform is a mechanical device primarily designed and manufactured with the intent to position people with the necessary tools and material to overhead elevated temporary workplaces. All other uses or alterations/modifications to the aerial work platform must be approved by HAULOTTE®.

This manual shall be considered a permanent component of the machine and shall be kept with the aerial work platform in the designated Manual Holder, at all times.

Safe operation of this product can only be assured if you follow the operating instructions contained in this manual. To ensure proper and safe use of this equipment, it is strongly recommended that only trained and authorized personnel operate and maintain the aerial work platform.

We would particularly like to draw your attention to 2 essential points :

- Comply with safety instructions.
- Use the equipment within the specified/published performance limits.

With regard to the designation of our equipment, we stress that this is purely for commercial purposes and not to be confused with the technical specifications. Only the specifications in this manual should be used to study the suitability of the equipment for the intended use.

This operator's manual is specific to the HAULOTTE® products listed on the cover page of this manual.



Original language and version :

Manuals in English and French are the original instructions. Manuals in other languages are translations of the original instructions.

The operator's manual does not replace the basic training required for equipment operators. HAULOTTE® has compiled this manual to assist in safe and efficient operation of the products covered in the manual.

The manual must be available to all operators and must be kept in a legible condition. Additional copies can be ordered from HAULOTTE Services®.

Stay Safe and keep working with HAULOTTE® !

A - Foreword

1 - User responsibility

1.1 - OWNER'S RESPONSIBILITY

The owner (or hirer) has the obligation :

- To inform operators of the instructions contained in the Operator's Manual.
- For applying the local regulations regarding operation of the machine.
- To replace all manuals or decals that are either missing or not legible. Additional copies can be ordered from HAULOTTE Services®.
- To establish a preventive maintenance program in accordance with the manufacturer's recommendations, taking into account the environment and severity of use of the machine.
- To perform periodic inspections in accordance with HAULOTTE® recommendations and local regulations.

All malfunctions and problems identified during the inspection shall be corrected before the aerial work platform is returned to service.

1.2 - EMPLOYER'S RESPONSIBILITY

The employer has the obligation :

- To authorize the operator to use the machine.
- To inform and familiarize the operator with the local regulations.

Forbid anyone from operating the machine if :

- Under the influence of drugs, alcohol, etc.
- Subject to fits, loss of motor skills, dizziness, etc.

1.3 - TRAINER'S RESPONSIBILITY

The trainer must be qualified to provide training to operators in accordance with applicable local regulations. The training must be given in an obstacle-free area until the trainee is considered competent as defined by the training program undertaken.

1.4 - OPERATOR'S RESPONSIBILITY

The operator has the obligation to :

- Read and understand the contents of this manual and familiarize himself with the decals affixed on the machine.
- To inspect the machine before use according to HAULOTTE®'s recommendations..
- To inform the owner (or hirer) if the manual or any decals are missing or are not legible.
- To inform of any malfunctioning of the machine.

The operator shall ensure that frequent inspections were conducted by the owners and the operator may only operate the machine for the purpose intended by the manufacturer.

Only authorized and qualified operators may operate HAULOTTE® machines.

All operators must become familiar with and fully understand the emergency controls and be able to operate the machine in an emergency.

The operator has the obligation to stop using the machine in the event of malfunction or safety problems on the machine or in the work area and report the problem immediately to his/her supervisor.

A - Foreword

2 - Safety

2.1 - SAFETY INSTRUCTIONS

2.1.1 - Misuse Hazards

- Do not use the machine for any other purpose than to position people, their tools and material to the overhead/elevated temporary work places.
- Do not use the machine as a crane, material lift or elevator. Only use the machine as it was intended.
- Do not attach overhanging loads when raising or lowering the platform.
- Do not tie the platform to an adjacent fixed or mobile structure.
- Do not use/operate the machine when alone. A survey person or immediate Supervisor must be present on the ground in case of emergency.
- Do not use a faulty or poorly maintained machine. Remove defective/damaged machine from service.
- Do not climb onto the compartment covers of the machine.
- Do not replace items critical to machine stability with items of different weight or specification.
- Do not replace factory-installed tires with tires of different specifications or ply rating.
- Do not alter or disable machine components that in any way affect safety and stability.
- Do not disable the safety devices.



A

B

C

D

E

F

G

H

I

A - Foreword

2.1.2 - Falling Hazards

To enter or exit from the platform :

- The machine must be completely stowed.
- Face the machine to access the entry opening to the platform.
- Keep 3 points of contact (both hands and a foot) on the steps and the guardrail.

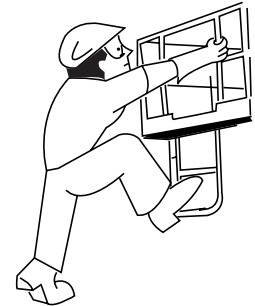

Before commencing operation :

- Ensure that guard rails are correctly installed and secured.
- Ensure that gate or sliding bar is in its proper closed position.
- Remove oil or grease from the steps, floor, handrail and the guardrails.
- Clear the platform floor free of debris.



When in the platform :

- Occupants must wear a harness in accordance with governmental regulations. Use a fall restraint harness adjusted to your size that has been inspected by a competent person.
- The correct use of the harness requires the lanyard to be connected to an anchorage point designated by the decals. Refer to this decal located on the platform.
- Hold on securely to the guardrails.
- Always keep your feet firmly on the floor of the platform.
- Do not sit, stand, or climb on the platform guard rails.
- Work only within the platform guardrails area and do not lean over guardrails to perform work.
- Do not exit the platform until it is in the completely stowed position.
- Do not use the guardrail as a means of access to climb in or out of the platform.

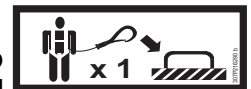

A - Foreword

2.1.3 - Overturning / Tip-over Hazards

Before positioning and operating the machine :

- Ensure that the surface is capable of supporting the machine weight including the rated capacity.
- Do not exceed the maximum rated capacity that includes the weight of both material and allowed number of occupants. Do not exceed the allowable number of occupants.
- Place the loads uniformly distributed on the platform floor.
- Do not increase the working height (using extensions, ladder, etc.).
- Do not place ladders or scaffolds in the platform or against any part of this machine.
- Do not use the machine in winds exceeding the permissible limit.
- Do not increase the surface area of the platform exposed to wind. This includes adding panels, mesh, banners. Be aware when working with materials with a large surface area. This will add to the wind load on the machine.
- Do not raise the platform or drive with platform elevated on an incline exceeding the rated slope for the machine.
- Do not drive the machine on slopes or grades exceeding the specified limits.
- Do not replace components critical to stability with components of different weight or specification.
- Never use the machine with material or objects suspended from the guard-rail.
- Do not pull or push towards any object outside of the platform. Do not exceed the maximum allowable side force stated in the performance specifications.
- Do not use the machine to support any external structure.
- Do not use the machine to tow other machines or to drag materials.



A

B

C

D

E

F

G

H

I

A - Foreword

Using a machine on a slope



Do not exceed the slope limit for each operation.  Section B 4.1 Technical specifications.

Gradeability :

- Driving in stowed position UP or DOWN a slope.



Sideslope :

- Driving in stowed position across a slope.



Rated slope :

- Operating with platform elevated.



- If the tilt alarm sounds with the platform uphill : Stow the machine completely.
- If the tilt alarm sounds with the platform facing downhill : Stow the machine completely.
- **While driving on a slope:**
 - Always orientate the machine in the direction of the slope.
 - Stow the machine completely.
 - Do not travel down slopes in high speed.
 - Do not drive fast in narrow or cluttered areas. Keep speed under control while making turns or sharp bends.

WIND : The aerial work platform can operate up to a maximum wind speed as indicated in the specifications. To identify the local wind speed, use the Beaufort scale below, use a wind gauge or an anemometer.

A - Foreword

N.B.:-THE BEAUFORT SCALE OF WIND FORCE IS ACCEPTED INTERNATIONALLY AND IS USED WHEN COMMUNICATING WEATHER CONDITIONS. A WIND SPEED RANGE AT 10 M (32 FT 9 IN) ABOVE FLAT, CLEAR LAND IS ASSOCIATED WITH EACH DEGREE.

Beaufort scale

Force	Meteorological description	Observed effects	m/s	km/h	mph
0	Calm	Smoke rises vertically.	0 - 0,2	0 - 1	0 - 0,62
1	Very light breeze	Smoke indicates the wind direction.	0,3 - 1,5	1 - 5	0,62 - 3,11
2	Light breeze	Wind felt on the face. Leaves rustle. Weather vanes turn.	1,6 - 3,3	6 - 11	3,72 - 6,84
3	Slight breeze	Leaves and small twigs in constant motion. Flags move slightly.	3,4 - 5,4	12 - 19	7,46 - 11,8
4	Nice breeze	Raised dust and loose papers. Small branches are moved.	5,5 - 7,9	20 - 28	12,43 - 17,4
5	Nice breeze	Small trees in leaf to sway. Crested wavelets form on inland waterways.	8,0 - 10,7	29 - 38	18,02 - 23,6
6	Cool wind	Large branches in motion. Power lines and chimneys 'sing'. Umbrellas used with difficulty.	10,8 - 13,8	39 - 49	24,23 - 30,45
7	Near gale	Whole trees in motion. Inconvenience felt when walking against wind.	13,9 - 17,1	50 - 61	31 - 37,9
8	Squall	Some branches break. Generally we cannot walk against the wind.	17,2 - 20,7	62 - 74	38,53 - 45,98
9	Strong squall	The wind causes slight damage to buildings. Tiles and chimney stacks are blown off.	20,8 - 24,4	75 - 88	46,60 - 54,68

A - Foreword

2.1.4 - Electrocuting Hazards

The machine is not electrically insulated and does not provide protection from contact or proximity to electrically charged conductors.

Always position the lift at a safe distance from electrically charged conductors to ensure that no part of the machine is within an unsafe area.

Respect the local rules and the minimum safety distance from power lines.

Minimum safe approach distances

Electric voltage	Minimum safety distance	
	Mètre	Feet
0 - 300 V	Avoid contact	
300 V - 50 kV	3	10
50 - 200 kV	5	15
200 - 350 kV	6	20
350 - 500 kV	8	25
500 - 750 kV	11	35
750 - 1000 kV	14	45

N.B.-:USE THIS TABLE EXCEPT WHERE LOCAL REGULATIONS INDICATE OTHERWISE.

- Do not operate the machine when close to live power lines, consider the movement of the machine and the sway of the electric power lines particularly in windy conditions.
- Do not operate the machine during lightning, thunderstorms, snow/ice or any weather condition that could compromise operator safety.
- Do not use the machine as a ground for welding.
- Do not weld on the machine without first disconnecting the battery terminals.
- Always disconnect ground cable first.
- The machine must not be used while charging the batteries.
- When using the platform AC power line, ensure it is protected with a circuit breaker.

Keep away from the machine if it contacts energized power lines. Personnel on the ground or in the platform must not touch or operate the machine until energized power lines are shut off.



A - Foreword

2.1.5 - Explosion / Fire Hazards

Always wear protective clothing and eye wear when working with batteries and power sources/systems.

N.B.:-ACID IS NEUTRALIZED WITH SODIUM BICARBONATE AND WATER.

- Do not work on or operate a machine in an explosive or flammable atmosphere / environment.
- Do not touch hot components.
- Do not bridge the battery terminals with metallic objects.
- Do not service the battery in proximity of spark, open flame, lit cigarettes.



A

B

C

D

E

F

G

H

I

A - Foreword

2.1.6 - Crushing / Collision Hazards

When in the platform :

- Check the work area for overhead clearance, for any obstacles besides and below the platform when raising/lowering the platform and or before driving.
- During movement, keep all the parts of the body inside the platform. Hold onto the guardrails on the opposite side to any surrounding structures. Take care to avoid trapping hands whilst holding the guardrails.
- To position machine close to a building/structure, use extension deck feature, instead of driving machine closer to structure.
- Always cordon off the area around the base of the machine to keep personnel and other equipment away from the machine while in use.
- Warn personnel not to work, stand, or walk under a raised boom/platform.
- Do not drive in reverse direction (opposite the field of vision).
- Always ensure that the chassis is never driven any closer than 1 m (3 ft 3 in) to holes, bumps, slopes, obstructions, debris and ground coverings that may hide holes and other dangers.
- Keep non-operating personnel at least (16 ft 5 in) away from the machine when driving.
- Be aware of driving direction.
 - Check the driving direction with the help of the red or green arrow on the chassis relative to the red and green arrows on the platform control box.
 - Also note that when changing the driving direction (Forward <> Reverse) the joysticks or switches must return to the neutral position before reversing the drive direction and for movement to occur.
- When driving, position the platform so as to provide the best possible visibility and to avoid any blind spots.
- Hold on securely to the guardrails.
- Occupants must wear a harness in accordance with governmental regulations. Use a fall restraint harness adjusted to your size that has been inspected by a competent person.
- Lanyard must be attached to the designated anchorage point.
- Avoid contact with fixed or mobile obstacles (other machines).
- Other machines (crane, aerial work platform, etc.) operating in the work area increase the risk of crushing or collision. Restrict the operation of machines moving within the aerial work platform work area.
- Take into consideration the stopping distance, reduced visibility and blind spots of the machine.
- Limit travel speed to suit the ground surface condition, slope (incline), and people in the vicinity.

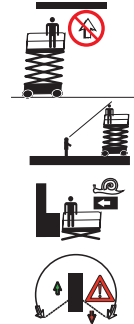

A - Foreword

2.1.7 - Uncontrolled movement Hazards

Do not use a damaged or malfunctioning machine.

Be aware of uncontrolled movement and always respect the following :

- Maintain clearance from high voltage lines.
- Maintain clearance from generators, radar, electromagnetic fields.
- Never expose the batteries or electrical components to water (high pressure washer, rain).
- Never tow the machine over extended distances.
- In case of a machine breakdown, it is possible to tow short distance to load it onto a trailer.
- Never leave the hydraulic cylinders fully extended before switching off the machine, or when stationary for an extended period of time.
- Lower the arms to the stowed position.
- Select a safe parking location, on a firm level surface, clear of obstruction and traffic.
- Ensure all compartments are closed and secured.
- Chock the wheels.

A

B

C

D

E

F

G

H

I

A - Foreword

3 - Safety inquiries

Inquiries relating to design criteria/specifications of a product, standards compliance, or overall machine safety should be sent to the HAULOTTE® PRODUCT SAFETY department.

Each inquiry or request should include all relevant information; including contact name, telephone number, mailing address, email address, plus the machine model and serial number.

The HAULOTTE® Product Safety department will evaluate each request/inquiry and will provide a written response.

4 - Incident notification

Notify HAULOTTE® immediately when a HAULOTTE® product has been involved in an incident/accident leading to personal injury or death, or when there is a major property damage.

<p>HAULOTTE Group - EUROPE Product Safety Department</p> <p>Address : La Péronnière - BP 9 - 42152 L'Horme - France</p> <p>Tel : +33 (0)4 77 29 24 24</p> <p>Email : ProductSafety@haulotte.com</p>	<p>HAULOTTE Group - Australia, India and Asia Product Safety Department</p> <p>Address : 46 Green Road - VIC 3175 - Dandenong - Australia</p> <p>Tel : +61 3 9792 1000</p> <p>Email : ProductSafety@haulotte.com</p>	<p>HAULOTTE Group - North & South America Product Safety Department</p> <p>Address : 125 Taylor Parkway, Archbold, OH 43502 - United States</p> <p>Tel : +1 419 445 8915</p> <p>Email : ProductSafety@haulotte.com</p>
---	--	--

5 - Compliance

5.1 - PRODUCT INFORMATION

Without the written permission from Haulotte, modifying a HAULOTTE® product is a Safety concern. Any modification may violate Haulotte design parameters, government regulations and industry standards.

If you desire a modification to the product, submit a request in writing to HAULOTTE®.

With the utmost care to ensure enhanced reliability and greater safety of the HAULOTTE® products, it is pertinent that when a "Service or Safety Bulletin" is issued, action is taken immediately. Once the bulletin has been addressed, make sure that the completed form is submitted to HAULOTTE®.

Do not hesitate to contact HAULOTTE Services®, should you have any questions relating to the issued bulletin(s) or with questions on the policy itself.

5.1.1 - Change of Ownership Notification

It is important and necessary to keep HAULOTTE Services® updated with current ownership of the machine. This way, HAULOTTE® will be able to provide the necessary support for the product. If you have sold or transferred this machine(s); it is your responsibility to notify HAULOTTE Services®. It is not required to include Lessees/Renters of Leased/Rented machines on this form.

Use the HAULOTTE® Product Status Notification form to report scrapped, stolen, missing or recovered machine(s).

A - Foreword

5.1.2 - Owner information update form

Owner information update form

Complete this form and mail or fax it to :

HAULOTTE® subsidiary Name :

Address 1 :

Fax :

Address 2 :

e.mail address :

Address 3 :

Product information :

Model :

Machine serial number :

Owner / Servicing information : Do not include leased or rented units in this form

Current product owner 1 :

Current product owner 2 :

Name :

Name :

Company :

Company :

Address 1 :

Address 1 :

Address 2 :

Address 2 :

Country :

Country :

Phone :

Phone :

Date of ownership :

Date of ownership :

Signature :

Signature :

Date :

Date :

Company stamp is mandatory :

Company stamp is mandatory :

Tick here if the machine has been permanently removed from service (scrapped). The manufacturer's nameplate must be removed and returned to HAULOTTE Group when the unit is removed from service.

Reason for removal :

A - Foreword

5.2 - PRODUCT SPECIFICATIONS

HAULOTTE® cannot be held liable for any changes to the technical characteristics/ specifications contained in this manual. HAULOTTE® has a continuous improvement policy in place for its product range; given this policy, the Company reserves the right to modify their products technical characteristics / specifications without notice.

Certain options can modify the machine's operating characteristics and its' associated safety. If your machine was originally delivered with options fitted, replacing a safety component associated with a particular option does not require any particular precaution other than those associated with the installation itself (static test)

Otherwise, it is essential to follow the manufacturer's recommendations as stated below :

- Installation by authorised HAULOTTE® personnel only.
- Update the manufacturer's identification plate.
- Have stability tests carried out by a certified agency/competent person.
- Ensure decals are updated.

B - Familiarization

1 - General safety

1.1 - INTENDED USE

To ensure the safe use of an Aerial Work Platform, support personnel must always be available on the ground. If necessary, support personnel will be required to operate the emergency functions of the machine and in rescuing the operator.

Do not operate the product in the following situations :

- On soft, unstable or cluttered ground.
- With wind blowing faster than the permissible limit.
 - Check the allowable wind speed specified in the performance specifications tabulation.
 - Consult the Beaufort scale.
- Close to power lines. Keep a safe distance.
- Outside of the temperature range -20°C / $+50^{\circ}\text{C}$ (-4°F / $+122^{\circ}\text{F}$).
- In an explosive atmosphere / environment.
- During storms.
- In the presence of strong electromagnetic fields.

N.B.-:USE THE MACHINE UNDER "NORMAL" CLIMATIC CONDITIONS. IF YOU NEED TO USE THE MACHINE IN CLIMATIC CONDITIONS LIKELY TO CAUSE DETERIORATION (EXTREME : HUMIDITY, TEMPERATURES, SALINITY, CORROSIVENESS, ATMOSPHERIC PRESSURE), CONTACT HAULOTTE SERVICES®. REDUCE INTERVALS BETWEEN SERVICING.

N.B.-:WHILE THE MACHINE IS NOT IN USE, CARE MUST BE TAKEN TO BRING THE MACHINE TO THE FULLY STOWED POSITION. ENSURE THAT THE MACHINE IS LOCKED IN A SECURE LOCATION, AND THE CONTROL KEY IS REMOVED TO PREVENT UNAUTHORISED USE OF THE MACHINE.

B - Familiarization

1.2 - DECAL CONTENT

Decals are provided to alert the user of hazards inherent with the Aerial Work Platforms.

Decals provide the following information :

- The level of severity.
- The specific hazard.
- A method to avoid, suppress or reduce the hazard.
- Descriptive text (where required).

Familiarize yourself with the decals and the hazard severity levels.

CE and AS standards



ANSI and CSA standards



Marking	Description
1	Hazard symbol
2	Level of severity
3	Avoidance symbol pictorial
4	Avoidance text

Decals must be kept in good legible condition.

Familiarize yourself with the decals and their respective color codes.







Additional decals can be ordered from HAULOTTE Services®.

B - Familiarization











1.3 - SYMBOLS AND COLORS

Symbols and colors are used to alert the operator of safety precautions and/or to highlight important safety information.

The following safety symbols are used throughout this manual to indicate specific hazards and the hazard severity level when operating or maintaining the Aerial Work Platform.

Symbol	Description
	Danger : Risk of injury or death
	Caution : Risk of material damage
	Prohibited action
	Reminder to use good practice or follow pre-operation checks
	Cross-reference to another part of the manual
	Cross-reference to another manual
	Cross-reference to repair (contact HAULOTTE Services®)
N.B. :	Additional technical information

1.4 - LEVEL OF SEVERITY

Color	Title	Description
		Danger : Indicates a hazardous situation which if not avoided, WILL result in death or serious injury.
		Warning : Indicates a hazardous situation which if not avoided, COULD result in death or serious injury.
		Caution : Failure to comply could result in minor or moderate injury.
		Notice : Indicates recommended practices if not followed, may result in a malfunction or damage the machine or its components.
		Procedure : Indicates a maintenance operation.

B - Familiarization

1.5 - SYMBOLS LEGEND AND DEFINITIONS

Symbols are used throughout this manual to depict hazards, avoidance measures and indicate when information is required.

Refer to the following table to familiarize yourself with these symbols.

Symbol	Description	Symbol	Description	Symbol	Description
	Body crushing hazard		Foot crushing hazard		High pressure fluid ejection hazard
	Hand crushing hazard		Entanglement hazard		Health-damaging effects from hot work environment
	Health/safety hazards related to chemicals		Burns and scalds from contact with flames, explosion or radiation from heat sources		Injury from Electric arcs - Energy supply disconnecting devices - Batteries fire, emissions, etc
	Electrical contact or lightning strike		Tip over due to excessive loading / wind load and excessive ground slope		Relate and coordinate directional arrows on the chassis with those on the control box
	Risk of operator(s) falling		Do not put foot in this area		Do not put your hand in this area
	Never expose batteries and electrical component to high pressure washer		Ensure entry drop rail is down		Keep away from product working area
	Flames prohibited		Maintain safe clearance from high voltage electrically charged conductors as described in manual - Do not use in thunderstorms		Overload
	Refer to operator manual		Safety belt		Use appropriate lanyard attached to dedicated anchor point.
	Wheel pressure		Enable switch		Use safety prop before attempting any maintenance work
	Tow point		Tie down point		Lift point
	Keep away from hot surfaces		Wear protective equipment		

B - Familiarization

2 - Models description

Regulation	Models
ANSI and CSA standards	OPTIMUM 1931 E
CE and AS standards	OPTIMUM 8

A

B

C

D

E

F

G

H

I

B - Familiarization

3 - Primary machine components

3.1 - LAYOUT

OPTIMUM 8 - OPTIMUM 1931 E

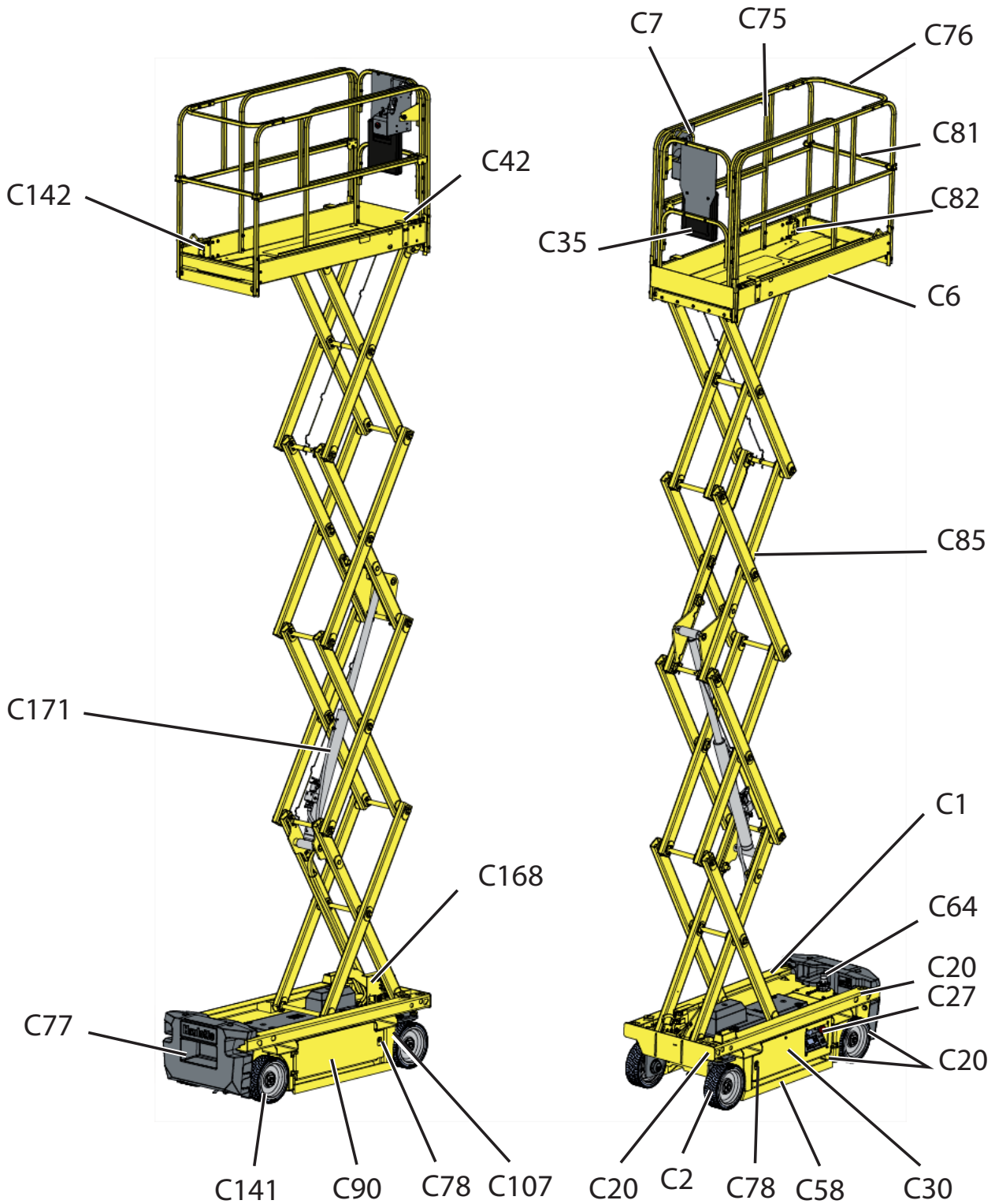

B - Familiarization

Marking	Description	Marking	Description
C1	Chassis	C77	Platform access ladder
C2	Front drive wheels	C78	Compartment locking latch
C6	Platform	C81	Sliding guardrail
C7	Platform control box	C82	Deck extension handle
C20	Tie-down (and/or forklift loading)	C85	Scissors
C27	Ground control box	C90	Battery bay (block)
C30	Hydraulic oil tank	C107	Pull T-handle for emergency lowering
C35	Document holder	C141	Rear wheel
C42	'Enable Switch' pedal (Optional - Not shown)	C142	Lanyard attachment points
C58	Pothole protection	C168	Maintenance support
C64	Tilt sensor	C169	Folding guardrails (Optional - Not shown)
C75	Extension desk	C171	Scissors lifting cylinder
C76	Guardrail		

3.2 - MAINTENANCE SUPPORT

The maintenance stand must be in place before any maintenance operation is begun.

Placing the machine in maintenance configuration :

- Lift scissor arms to a sufficient height (floor of the platform at around 2,5 m / 8 ft 2 in from the ground).
- Pull the plastic handle and put the stand in the vertical position.
- Release the handle. The stand should remain in the vertical position.
- Lower the scissor arms.
- Scissor arm pivoting rod should rest on the V groove of the stand.

Putting in use position :

- To put back the machine into its normal operation, reverse the steps used above.



B - Familiarization

3.3 - GROUND CONTROL BOX

3.3.1 - Layout

General view

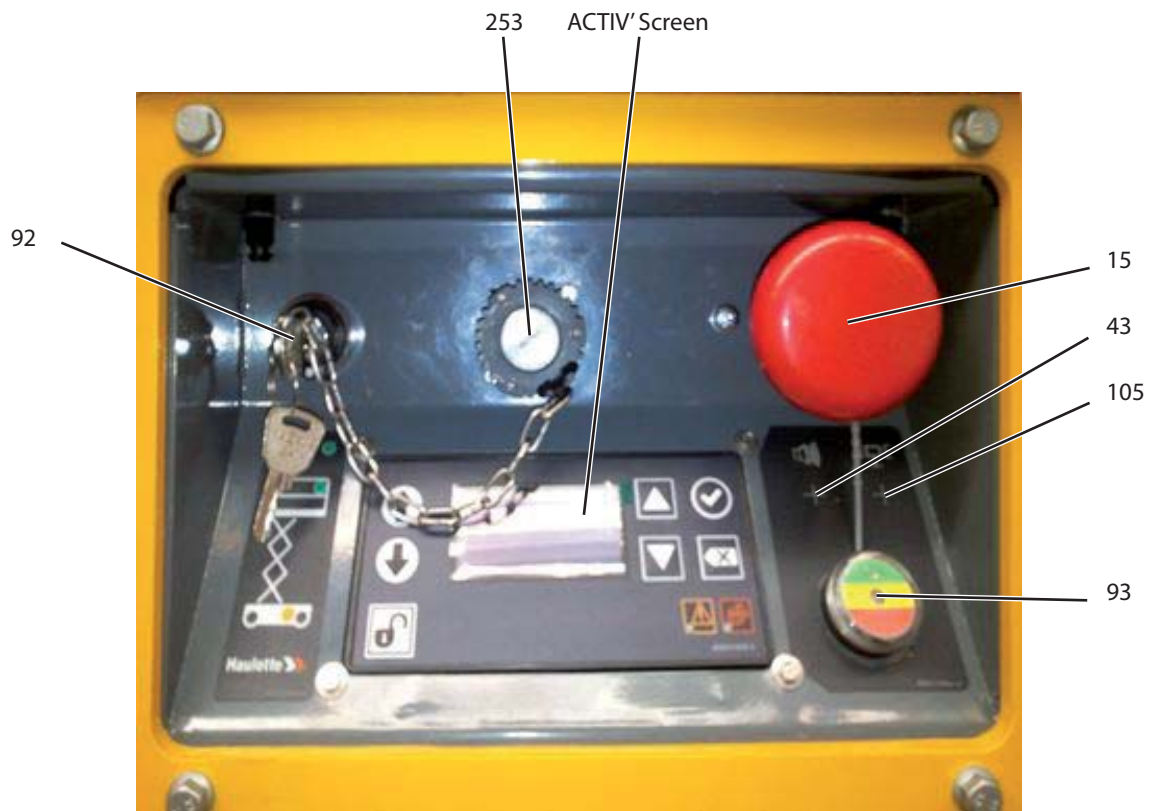

Controls and indicators

Marking	Description	Function
15	E-stop button	Pulled out : Ground control box energized Pushed in : De-energizes control system
43	Horn button	Not used
92	Control box activation key selector	Right : Ground control box energized Center : De-energizes control system Left : Platform control box energized
93	Battery charging indicator	Battery charger status
105	Beacon light (Optional)	Move upwards : Flashing light turn ON Move downwards : Flashing light turn OFF
253	Diagnostic tool socket	Connection to the diagnostic tool (HaulotteDiag)

B - Familiarization

3.3.2 - HAULOTTE Activ'Screen

Upon starting and during operation of the machine, the LCD screen "Activ'Screen" located on the ground control box displays in real time the machine operating status.

HAULOTTE Activ'Screen

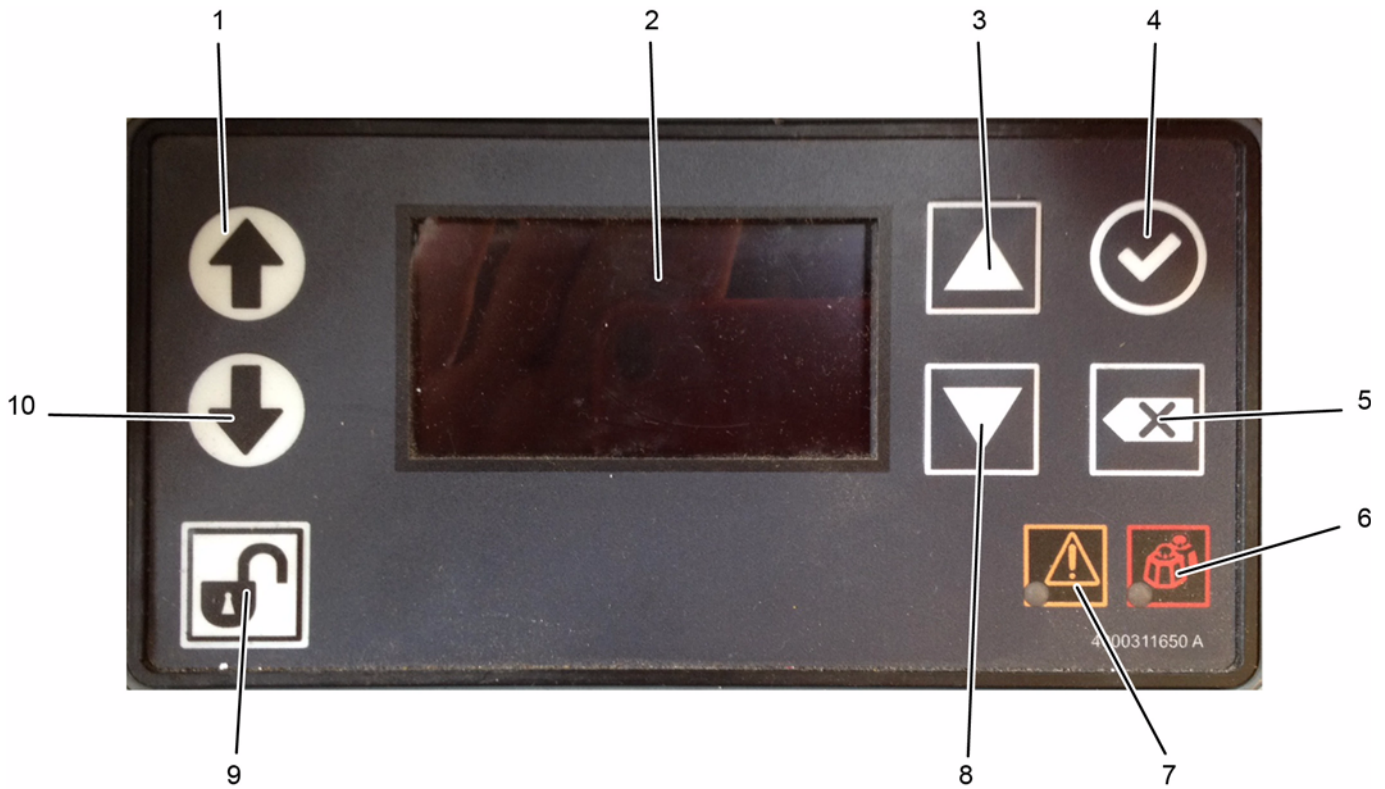

Controls and indicators

Marking	Description	Function
1	Platform raising control	Platform raises
2	LCD screen	Display status of operation of the machine
3	Navigation button	Navigation in the menus - Scroll up
4	Confirmation button	Validation in the menus
5	Cancellation button	Go back
6	Platform overload indicator	Platform overload indicator
7	Machine fault indicator light	Constantly lit in the event of an operation malfunction
8	Navigation button	Navigation in the menus - Scroll down
9	'Enable Switch' selector	Press in and hold : Enable switch
10	Platform lowering control	Platform lowers

B - Familiarization

3.3.2.1 - LCD screen

At startup with the ground or platform controls selected; system initiates a self check :

- Bar gets filled up.

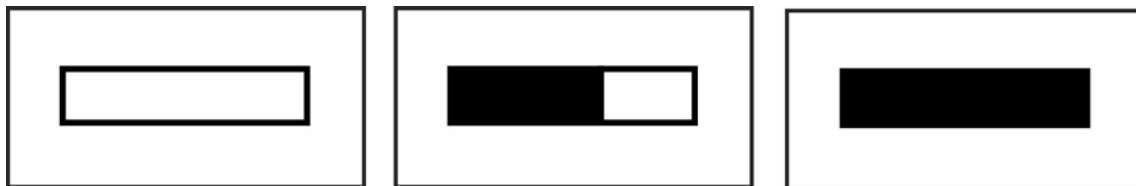

- Home screen comes on with status icon of the machine - okay to proceed functioning the controls.

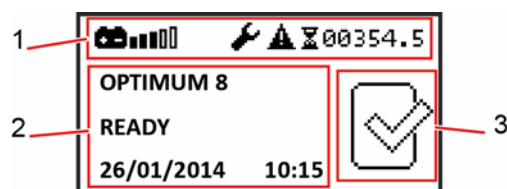

Symbol	Description
1	Information icons
2	Information text
3	Status icon of the machine

Symbol	Description
	Battery status
	Maintenance use
	Fault / alarms
	Hour meter

B - Familiarization

- After pressing on :

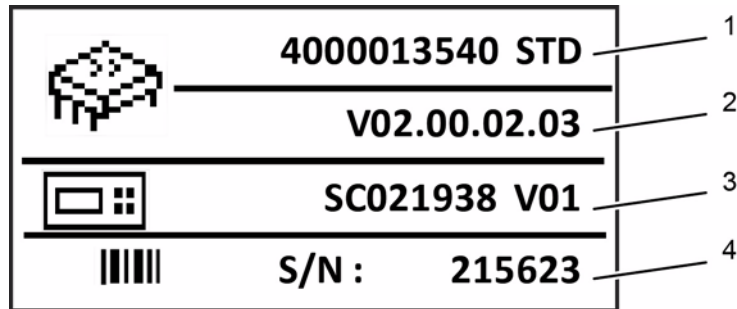

Symbol	Description
1	Software part number
2	Software version + Screen software version + Screen version
3	Screen identification + Screen software version
4	Machine serial number displayed

- After again pressing on
- Access code screen comes on - refer to maintenance manual for entering the access code

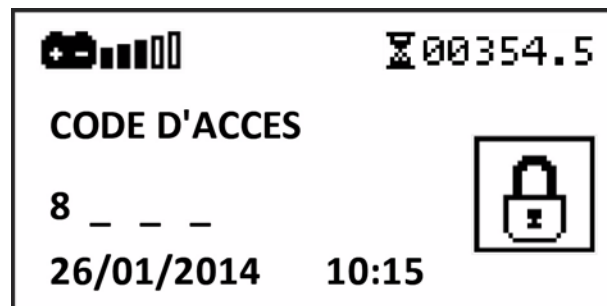

- Validation by pressing on is active only if access code is known and entered - refer to maintenance manual for the procedure for the different level code useage

B - Familiarization

Alarm status

Alarm status displayed as applicable - samples shown below

- Tilt

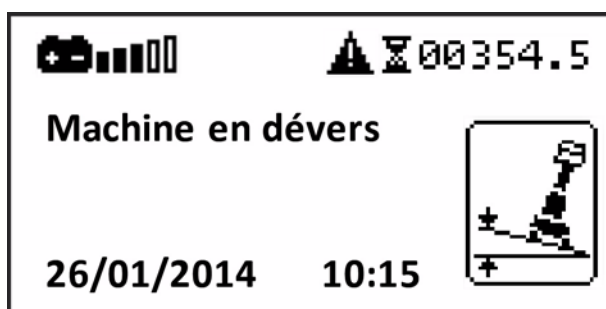

- Overload

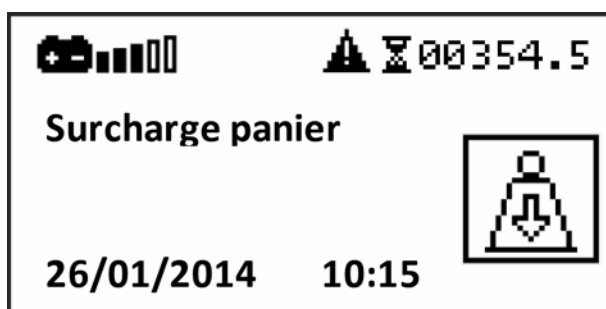

- Low battery

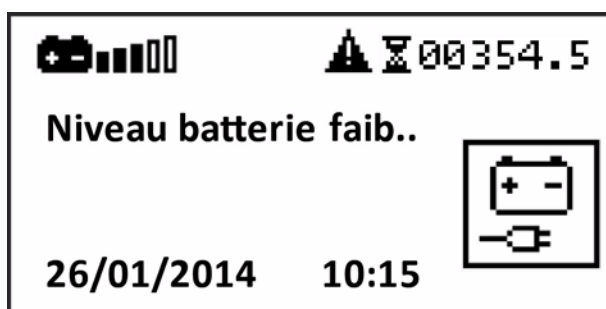

B - Familiarization

- Present fault

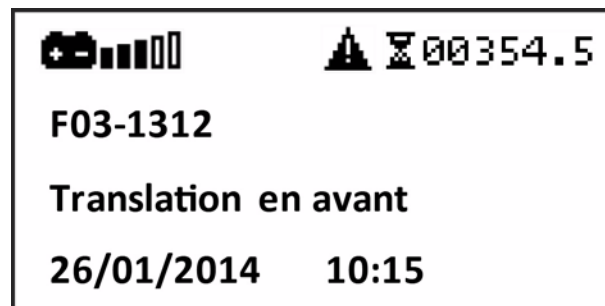

- Platform control box E-stop button

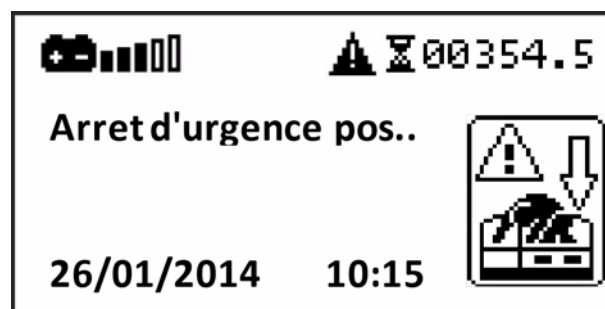

B - Familiarization

3.4 - PLATFORM CONTROL BOX

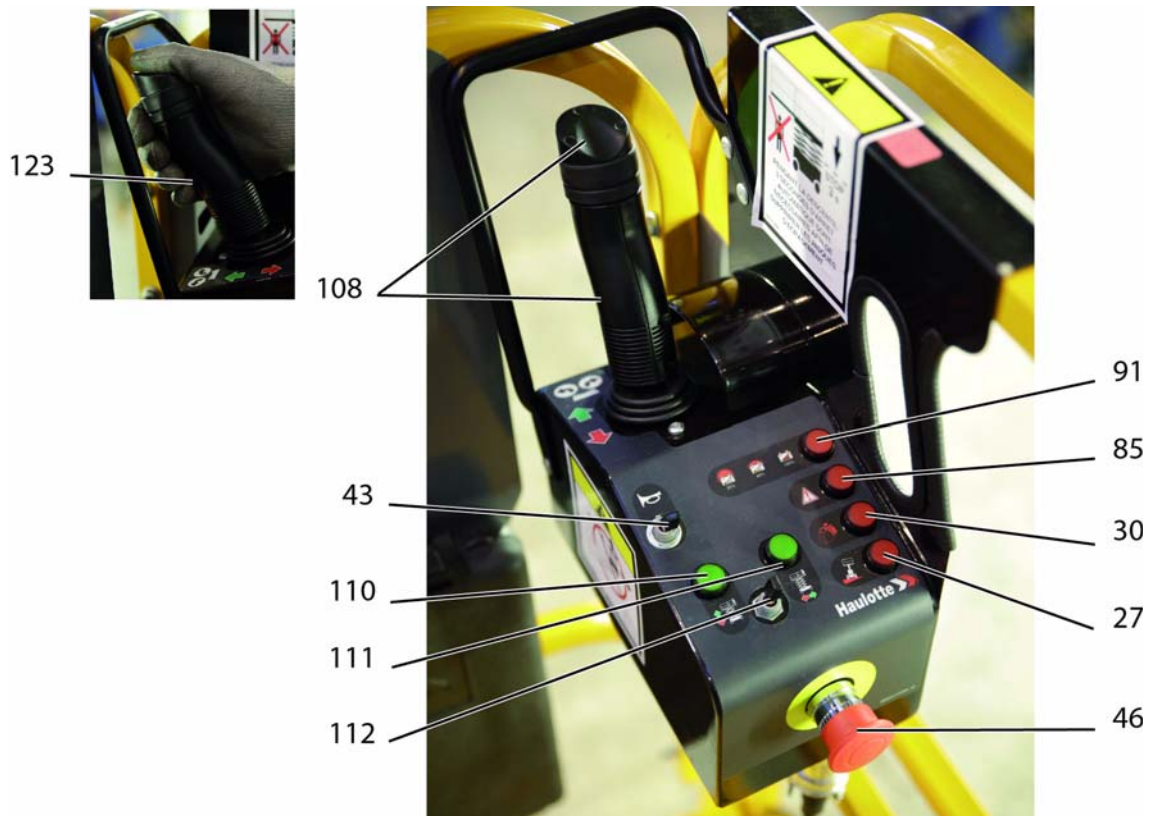

3.4.1 - Layout

General view

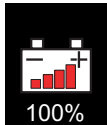

B - Familiarization

Controls and indicators

Marking	Description	Function
27	Tilt indicator	Machine on excessive slope
30	Overload indicator	Platform overloaded
43	Horn button	Move upwards and hold to activate horn
46	E-stop button	Pulled out : Platform control box power supply energized Pushed in : De-energizes control system
85	Fault indicator	Fault indicator Faulty or tilting or overloaded machine
		 100%
		Battery charged
91	Battery charging indicator	 40%
		Flashing : Batteries have 40 % charge left
		 20%
		Constantly on : Batteries have only 20 % charge left
108	Movement joystick	Move forward : Forward drive or platform raising Move backwards : Reverse drive or platform lowering
	Front axle steering selector	Press right side of button : Right-hand steering Press left side of button : Left-hand steering
110	Raising / lowering selector	On : Raising / Lowering selection activated Off : Raising / Lowering movement is not selected
111	Driving selection indicator	On : Driving function activated Off : Driving movement is not selected
112	2-position selector	Move to the left : Platform raising / lowering Move to the right : Drive movements
123	'Enable Switch' selector	Press in and hold : Associated command is validated Release : Associated command movement is halted

B - Familiarization

4 - Performance Specifications

4.1 - TECHNICAL CHARACTERISTICS

Use the table to select the right Haulotte machine for the job.

CE and AS standards

Machine	OPTIMUM 8	
Characteristics - Dimensions	SI	Imp.
Maximum working height	7,77 m	25 ft 6 in
Maximum platform height	5,77 m	18 ft 11 in
Total weight	1520 kg	3,352 lbs
Maximum platform capacity	230 kg	500 lbs
Maximum number of occupants allowed	Indoor use : 2 Outdoor use : 1	
Maximum wind speed allowed	Indoor use : 0 km/h Outdoor use : 45 km/h	Indoor use : 0 mph Outdoor use : 28 mph
Manual force - CE - AS	Indoor use : 400 N (90 lbf) Outdoor use : 200 N (45 lbf)	
Gradeability	25 %	
Maximum side rated slope allowed - CE - AS	1,5°	
Maximum longitudinal rated slope allowed - CE - AS	3°	
Maximum load on wheel	963 kg	2,123 lbs
Maximum ground pressure of wheel on paved ground	13,84 daN/cm ²	209 lb/in ²
Drive speed :		
• Folded machine maximum speed	4,5 km/h	2.79 mph
• Unfolded machine maximum speed	0,5 km/h	0.3 mph
Maximum freewheel speed during towed operation	4,5 km/h	2.79 mph
Outside turning radius	1,5 m	4 ft 11 in
Inside turning radius	1 m	3 ft 3 in
Power source - Electric		
Battery	24 V - 105Ah (C5)	
Hydraulic tank capacity	6 l	1.6 gal US

B - Familiarization

ANSI and CSA standards

Machine	OPTIMUM 1931 E	
Characteristics - Dimensions	SI	Imp.
Maximum working height	7,77 m	25 ft 6 in
Maximum platform height	5,77 m	18 ft 11 in
Total weight	1440 kg	3,175 lbs
Maximum platform capacity	230 kg	500 lbs
Maximum number of occupants allowed	Indoor use : 2 Outdoor use : 2	
Maximum wind speed allowed	Indoor use : 0 km/h Outdoor use : 45 km/h	Indoor use : 0 mph Outdoor use : 28 mph
Manual force - ANSI - CSA	445 N	100 lbf
Gradeability	25 %	
Rated slope - ANSI - CSA	0°	
Maximum load on wheel	963 kg	2,123 lbs
Maximum ground pressure of wheel on paved ground	14,31 daN/cm ²	207 lb/in ²
Drive speed :		
• Folded machine maximum speed	4,5 km/h	2.79 mph
• Unfolded machine maximum speed	0,5 km/h	0.3 mph
Maximum freewheel speed during towed operation	4,5 km/h	2.79 mph
Outside turning radius	1,5 m	4 ft 11 in
Inside turning radius	1 m	3 ft 3 in
Power source - Electric		
Battery	24 V - 105Ah (C5)	
Hydraulic tank capacity	6 l	1.6 gal US

B - Familiarization

4.2 - WORKING AREA / RANGE OF MOTION

OPTIMUM 8 - OPTIMUM 1931 E

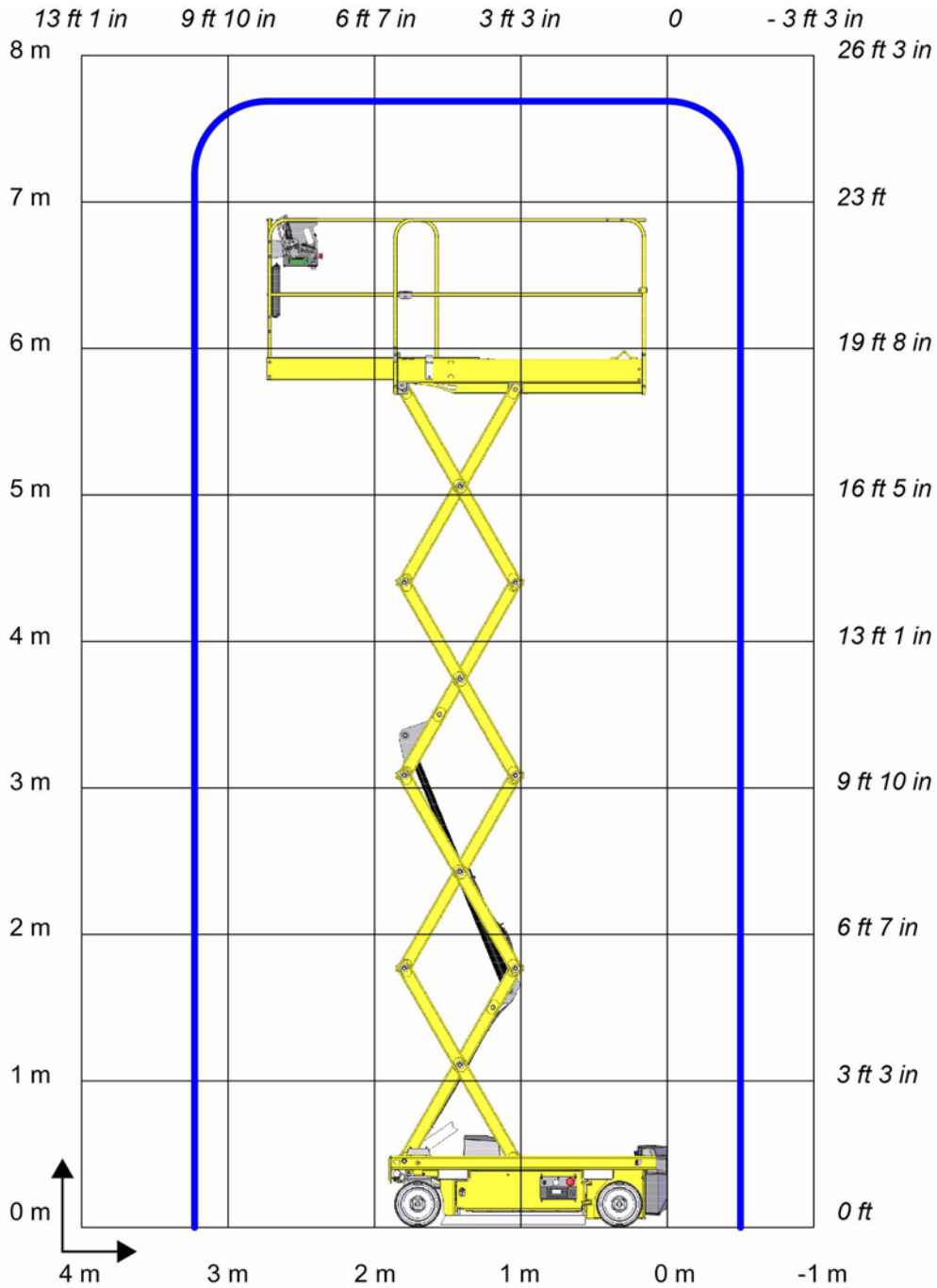

B - Familiarization

5 - Decals and markings locations

CE standard - OPTIMUM 8

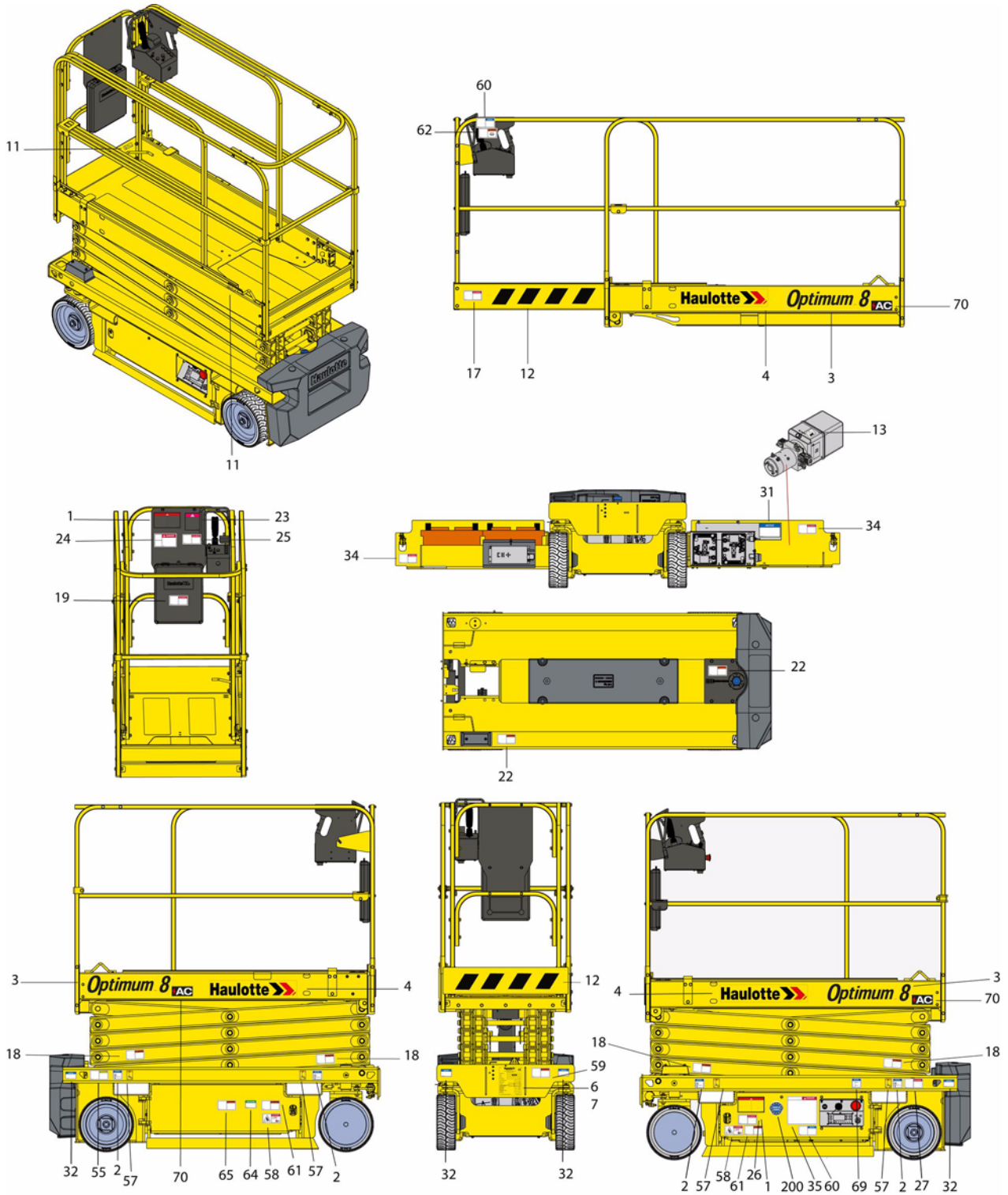

B - Familiarization

CE standard

Marking	Color	Description	Quantity	OPTIMUM 8
1	Red	Height of the floor and load	2	4000422970
2	Blue	Maximum Pressure per Tire - Floor Loading	4	4000417260
3	Other	Commercial name - Bright machine	2	3078146730
3	Other	Commercial name - Dark machine	2	307P222270
4	Other	Decal HAULOTTE® - 500 x 100 - Bright machine	2	307P217080
4	Other	Decal HAULOTTE® - 500 x 100 - Dark machine	2	307P224740
4	Other	Decal HAULOTTE® - 500 x 100 - Red machine	2	307P220360
5	Other	Identification plate	1	3078146180
11	Other	Lanyard attachment points	2	307P216290
12	Other	Material risk - Yellow and black adhesive tape	1	2421808660
13	Other	Hydraulic oil	1	307P221080
17	Red	Risk of crushing	2	4000244370
18	Orange	Hand crushing hazard - Risk of crushed hands	4	4000024890
19	Red	Operation instructions	1	4000025140
22	Orange	Wound foot - Do not place foot	2	4000027090
23	Red	Risk of crushing - Driving direction	1	3078145100
24	Red	Danger of electrocution	1	4000244350
25	Red	Risk of crushing - Closing drop rail	1	4000025080
26	Red	Danger of electrocution - Ground for welding	1	4000027100
27	Red	Verification of tilt operation	1	4000244380
31	Red	Brake release	1	4000361570
32	Blue	Anchorage point - Traction	4	4000027310
34	Red	Risk of electrocution - Water projection	2	4000025130
				In german : 307P222730 In english : 307P222740 In croatian : 4000360810 In danish : 307P222760 In spanish : 307P222770 In estonian : 4000360870 In finish : 307P222780 In french : 3078149030 In dutch : 307P222790 In hungarian : 4000360890 In italian : 307P222800 In japanese : 4000359830 In latvian : 4000359840 In lithuanian : 4000359850 In norwegian : 4000359900 In polish : 4000359860 In portuguese : 307P222810 In romanian : 4000359870 In slovakian : 4000359880 In slovenian : 4000359890 In swedish : 307P222820
35	Red	Operation instructions	1	
55	Yellow	Risk of electrocution - Charger - 240 V	1	4000273940
57	Other	Position of the lift truck forks	4	3078143830
58	Other	Battery compartment locking	2	4000310170
59	Red	Scissors safety	1	4000027550
60	Blue	Using the machine during battery charging is forbidden	1	4000273950
61	Blue	Risk of crushing	2	4000025060
62	Red	Stop time during descent	1	4000271010
64	Green	Battery verification	1	4000274040

B - Familiarization

Marking	Color	Description	Quantity	OPTIMUM 8
65	Orange	Hand crushing hazard - Battery	1	4000027440
68	Other	Transport height	1	4000417380
69	Other	Battery isolation switch	1	4000420660
70	Other	Electric traction AC	2	4000425350
200	Other	"Made in Europe"	1	4000137690

B - Familiarization

AS standard - OPTIMUM 8

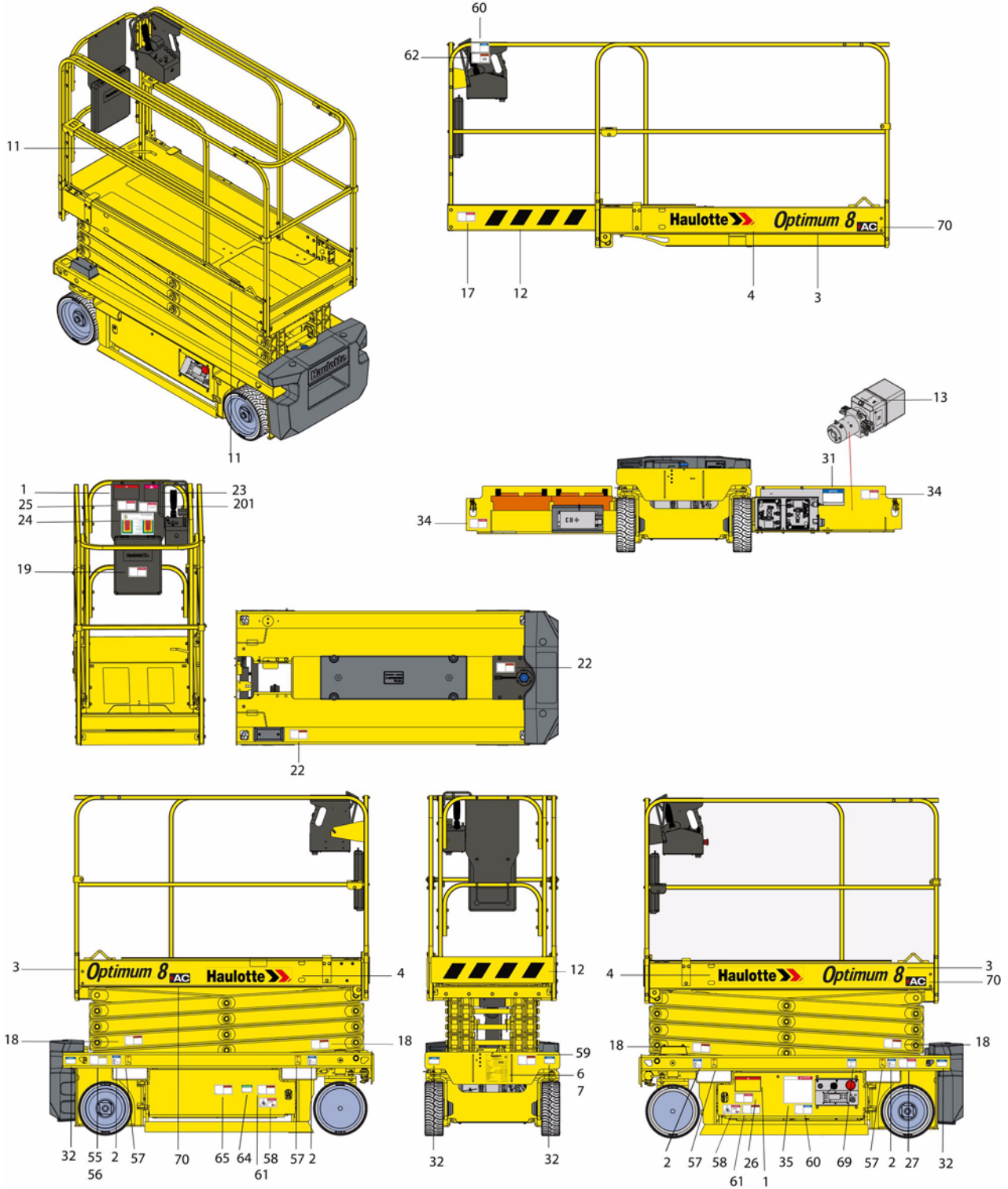

B - Familiarization**AS standard**

Marking	Color	Description	Quantity	OPTIMUM 8
1	Red	Height of the floor and load	2	4000422970
2	Blue	Maximum Pressure per Tire - Floor Loading	4	4000417260
3	Other	Commercial name - Bright machine	2	3078146730
3	Other	Commercial name - Dark machine	2	307P222270
4	Other	Decal HAULOTTE® - 500 x 100 - Bright machine	2	307P217080
4	Other	Decal HAULOTTE® - 500 x 100 - Dark machine	2	307P224740
4	Other	Decal HAULOTTE® - 500 x 100 - Red machine	2	307P220360
5	Other	Identification plate	1	3078146180
11	Other	Lanyard attachment points	4	307P216290
12	Other	Material risk - Yellow and black adhesive tape	1	2421808660
13	Other	Hydraulic oil	1	307P221080
17	Red	Risk of crushing	2	4000244370
18	Orange	Hand crushing hazard - Risk of crushed hands	4	4000024890
19	Red	Operation instructions	1	4000025140
22	Orange	Wound foot - Do not place foot	2	4000027090
23	Red	Risk of crushing - Driving direction	2	3078145100
24	Red	Danger of electrocution	1	4000227500
25	Red	Risk of crushing - Closing drop rail	1	4000025080
26	Red	Danger of electrocution - Ground for welding	2	4000027100
27	Red	Verification of tilt operation	1	4000244380
31	Red	Brake release	1	4000361570
32	Blue	Anchorage point - Traction	4	4000027310
34	Red	Risk of electrocution - Water projection	2	4000025130
35	Red	Operation instructions	1	307P222740
55	Yellow	Risk of electrocution - Charger - 240 V	1	4000307410
57	Other	Position of the lift truck forks	4	3078143830
58	Other	Battery compartment locking	2	4000310170
59	Red	Scissors safety	1	4000027550
60	Blue	Using the machine during battery charging is forbidden	1	4000310290
61	Blue	Risk of crushing	2	4000025060
62	Red	Stop time during descent	1	4000271010
64	Green	Battery verification	1	4000274040
65	Orange	Hand crushing hazard - Battery	1	4000027440
68	Other	Transport height	1	4000417380
69	Other	Battery isolation switch	1	4000420660
70	Other	Electric traction AC	2	4000425350
201	Red	Wearing a harness	1	4000275670

B - Familiarization

Russia and the Ukraine version - OPTIMUM 8

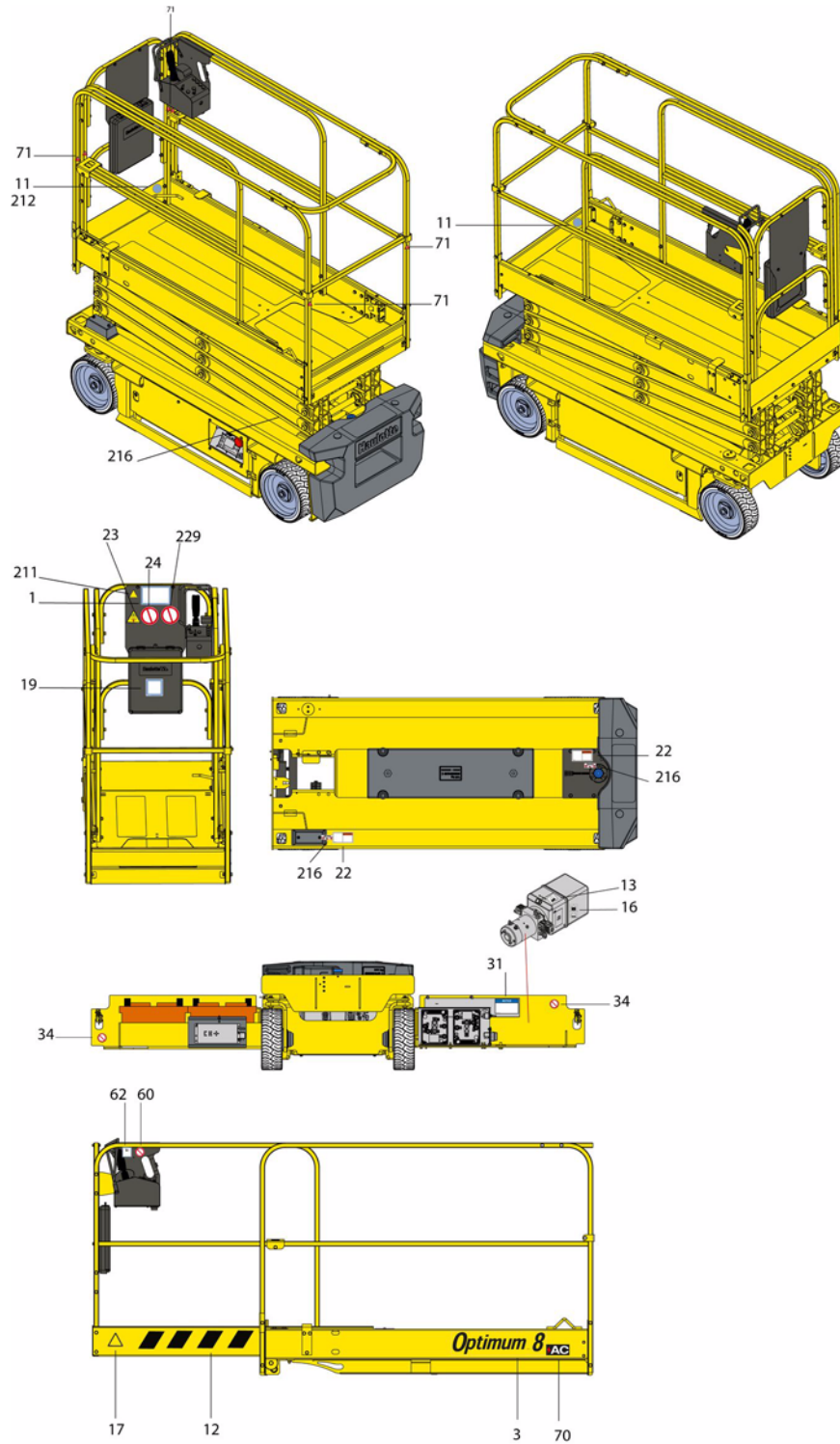

B - Familiarization

Russia and the Ukraine version - OPTIMUM 8

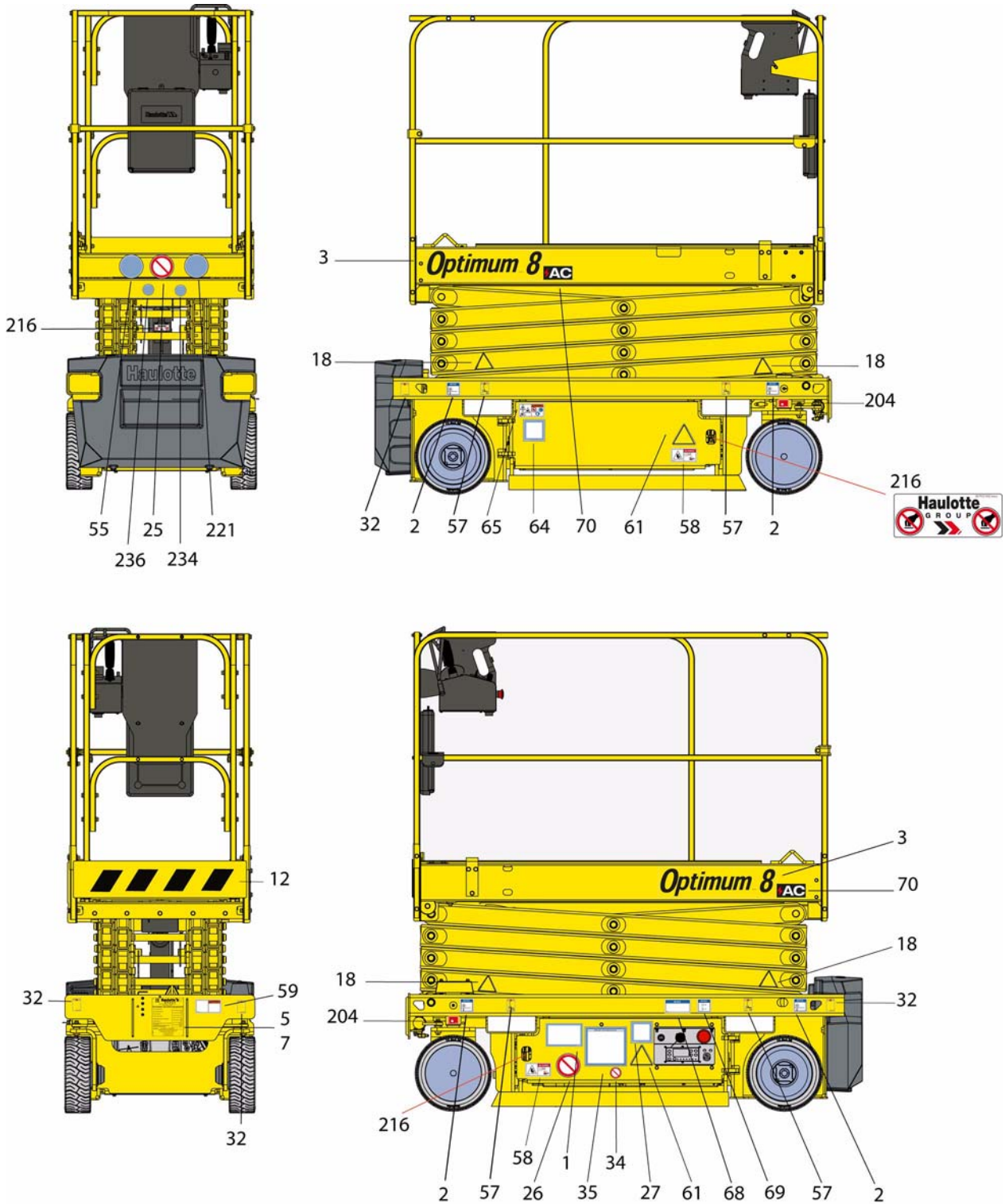

B - Familiarization**Russia and the Ukraine version**

Marking	Color	Description	Quantity	OPTIMUM 8
1	Red	Height of the floor and load	2	4000426450
2	Blue	Maximum Pressure per Tire - Floor Loading	4	4000417260
3	Other	Commercial name - Bright machine	2	3078146730
3	Other	Commercial name - Dark machine	2	307P222270
4	Other	Decal HAULOTTE® - 500 x 100 - Bright machine	2	307P217080
4	Other	Decal HAULOTTE® - 500 x 100 - Dark machine	2	307P224740
4	Other	Decal HAULOTTE® - 500 x 100 - Red machine	2	307P220360
5	Other	Identification plate	1	For Russia : 4000054110 For Ukraine : 4000054150
11	Other	Lanyard attachment points	4	307P226710
12	Other	Material risk - Yellow and black adhesive tape	1	2421808660
13	Other	Hydraulic oil	1	307P221080
17	Red	Risk of crushing	2	4000015610
18	Orange	Hand crushing hazard - Risk of crushed hands	4	307P227660
19	Red	Operation instructions	1	For Russia : 307P227190 For Ukraine : 307P227840
22	Orange	Wound foot - Do not place foot	2	307P227010
23	Red	Risk of crushing - Driving direction	2	For Russia : 4000010890 For Ukraine : 4000011390
24	Red	Danger of electrocution	1	4000010920
25	Red	Risk of crushing - Closing drop rail	1	307P226950
26	Red	Danger of electrocution - Ground for welding	2	307P226970
27	Red	Verification of tilt operation	1	For Russia : 307P227060 For Ukraine : 307P227870
31	Red	Brake release	1	4000361570
32	Blue	Anchorage point - Traction	4	4000013970
34	Red	Risk of electrocution - Water projection	2	307P226780
35	Red	Operation instructions	1	For Russia : 4000359910 For Ukraine : 4000359920
55	Yellow	Risk of electrocution - Charger - 240 V	1	307P227520
57	Other	Position of the lift truck forks	4	4000013830
58	Other	Battery compartment locking	2	4000310170
59	Red	Scissors safety	1	4000014340
60	Blue	Using the machine during battery charging is forbidden	1	307P226960
61	Blue	Risk of crushing	4	400270970
62	Other	Stop time during descent	1	For Russia : 4000011400 For Ukraine : 4000011430
64	Green	Battery verification	1	For Russia : 307P227180 For Ukraine : 307P227860
65	Orange	Hand crushing hazard - Battery	1	4000027440
68	Other	Transport height	1	4000417380
69	Other	Folding guardrails	1	4000420660
70	Other	Electric traction AC	1	4000425350
200	Other	"Made in Europe"	1	4000137690
204	Red	Lubrication point	2	307P219370
211	Red	Electrical danger	1	307P227620
212	Yellow	Electrical danger	1	307P227620
216	Other	Tamper-proof	6	307P227450
221	Blue	Obligatory routing	1	307P227510

B - Familiarization

Marking	Color	Description	Quantity	OPTIMUM 8
229	Red	Do not travel down the ramp at a fast speed	1	307P226990
234	Blue	Hand protection compulsory	1	307P226700
236	Blue	Wearing eye protection mandatory	1	307P226670

A

B

C

D

E

F

G

H

I

B - Familiarization

ANSI and CSA standards - OPTIMUM 1931 E

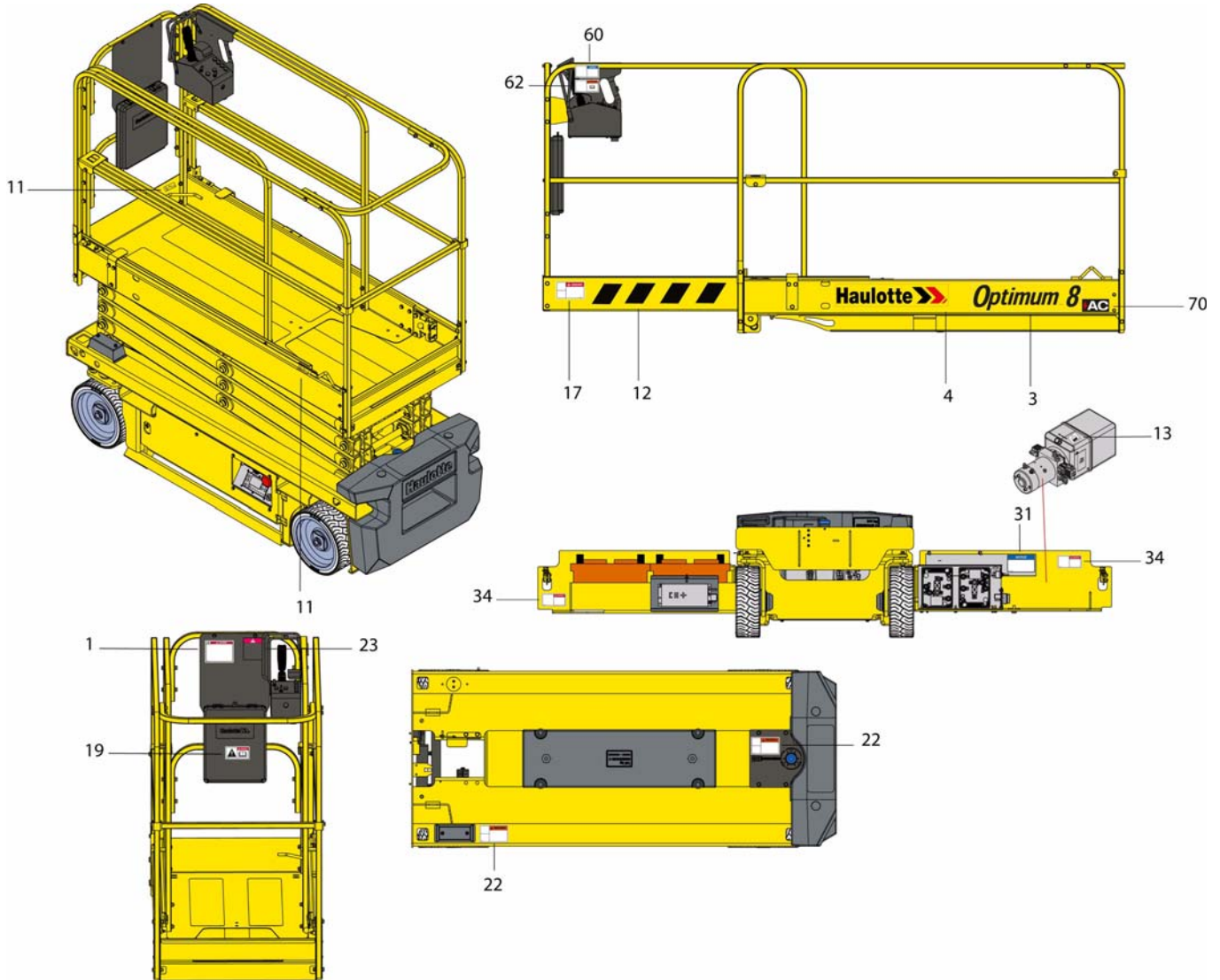

B - Familiarization

ANSI and CSA standards - OPTIMUM 1931 E

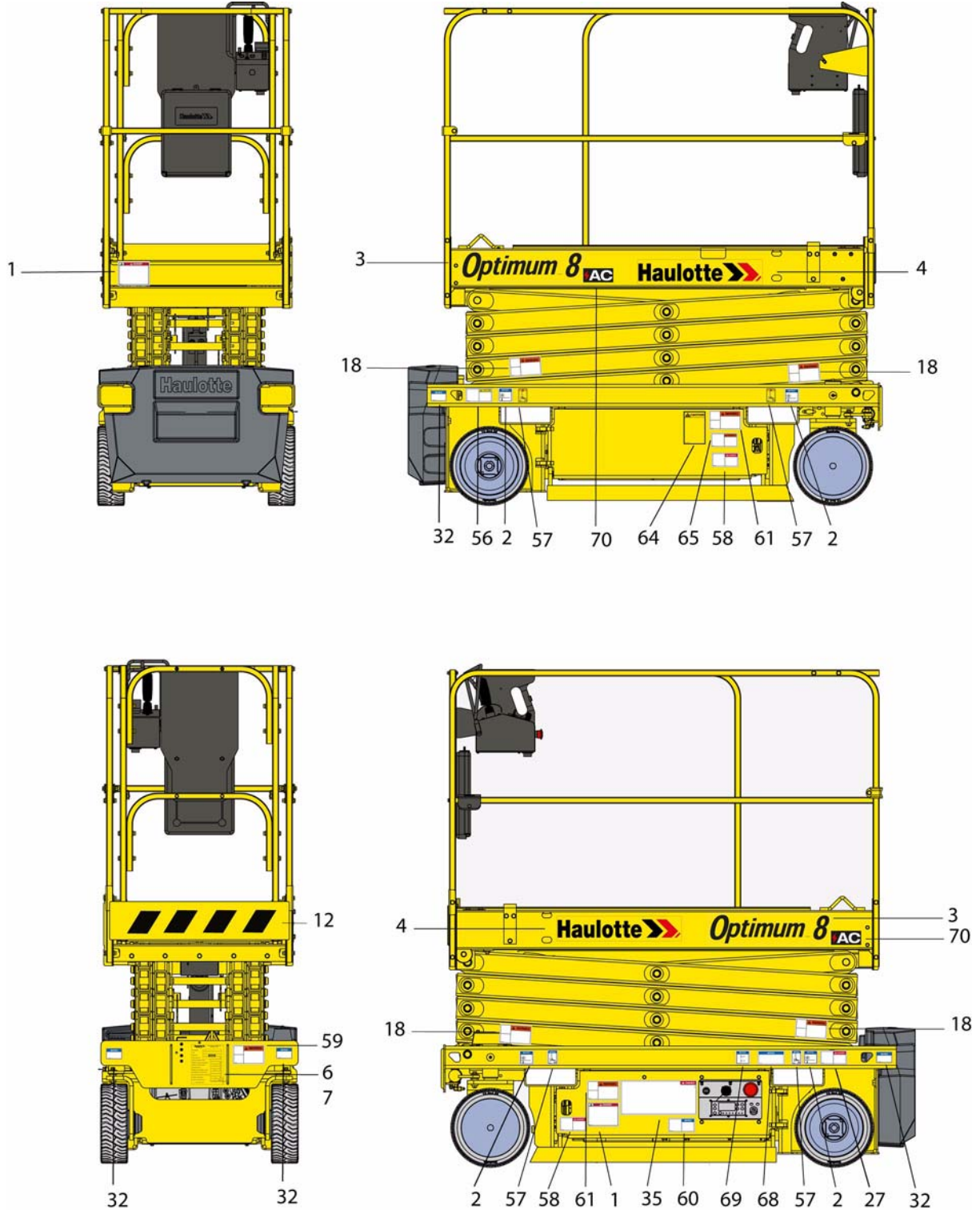

A

B

C

D

E

F

G

H

I

B - Familiarization**Russia and the Ukraine version**

Marking	Color	Description	Quantity	OPTIMUM 8
1	Red	Height of the floor and load	3	In english : 4000427710 In spanish : 4000427730 In french : 4000427720
2	Blue	Maximum Pressure per Tire - Floor Loading	4	4000427670
3	Other	Commercial name - Bright machine	2	3078148430
4	Other	Decal HAULOTTE® - 500 x 100 - Bright machine	2	307P217080
4	Other	Decal HAULOTTE® - 500 x 100 - Dark machine	2	307P224740
4	Other	Decal HAULOTTE® - 500 x 100 - Red machine	2	307P220360
5	Other	Identification plate	1	In english : 307P218170 In spanish : 4000088490 In french : 4000088480
11	Other	Lanyard attachment points	4	307P216290
12	Other	Material risk - Yellow and black adhesive tape	1	2421808660
13	Other	Hydraulic oil	1	307P221080
17	Red	Risk of crushing	2	In english : 4000130190 In spanish : 4000130210 In french : 4000130200
18	Orange	Hand crushing hazard - Risk of crushed hands	4	In english : 4000024770 In spanish : 4000086490 In french : 400067710
19	Red	Operation instructions	1	4000025140
22	Orange	Wound foot - Do not place foot	2	In english : 400002484 In spanish : 4000086610 In french : 4000068180
23	Red	Risk of crushing - Driving direction	2	3078145100
27	Red	Verification of tilt operation	1	In english : 4000130300 In spanish : 4000130320 In french : 4000130310
31	Red	Brake release	1	4000361570
32	Blue	Anchorage point - Traction	4	4000027310
34	Red	Risk of electrocution - Water projection	2	4000025130
35	Red	Operation instructions	1	In english : 4000243670 In spanish : 4000243690 In french : 4000243680
56	Yellow	Risk of electrocution - Charger - 110 V	1	3078148620
57	Other	Position of the lift truck forks	4	3078143830
58	Other	Battery compartment locking	2	4000310170
59	Red	Scissors safety	1	In english : 4000024850 In spanish : 4000086500 In french : 4000068070
60	Blue	Using the machine during battery charging is forbidden	1	4000310290
61	Blue	Risk of crushing	4	In english : 4000024780 In spanish : 4000086480 In french : 4000067700
62	Other	Stop time during descent	1	4000277380
64	Green	Battery verification	1	3078147330
65	Orange	Hand crushing hazard - Battery	1	In english : 4000025030 In spanish : 4000086550 In french : 4000068120
68	Other	Transport height	1	4000417380
69	Other	Folding guardrails	1	4000420660
70	Other	Electric traction AC	1	4000425350

C - Pre-operation inspection

1 - Recommendations

The owner, the site manager, the supervisor and the operator are all responsible to ensure the machine is fit for the work it is to perform; i.e. that the machine is suitable to carry out the work in complete safety and in compliance with this Operator's Manual. All managers who are responsible for persons operating the machine must be familiar with the local regulations currently applicable in the country of use and ensure that they are adhered to.

Before using the machine, read the previous chapters in this manual. Ensure that you have understood the following points :

- Safety precautions.
- Operator's responsibilities.
- Conditions and the operating principles of the machine.

2 - Working area assessment

To ensure safety during operation, the following should be considered :

- Segregate other site traffic (delivery vehicles, dumpers, etc) from the work area.
- Check the work area for localised features, e.g. manholes, service ducts, potholes, etc.
- Check ground covers (temporary and permanent) are strong enough to withstand the applied pressure
- Check ground covers are secured and monitor them. Take similar action for permanent covers.
- Establish the load bearing capacity (distributed load and point loading, e.g. outriggers) when working inside a building or on a structure.
- Provide supervision to ensure safe systems of work are appropriate and being used.
- Check for overhead crushing and contact hazards.
- Check weather conditions have not altered ground conditions (e.g. heavy or prolonged rain).
- Establish limits for safe operation (e.g. maximum wind speed). Remember conditions can change internally (e.g. if roller doors are opened).
- Comply with permit to work systems where sites have them (e.g. chemical plants).
- Provide a rescue plan for all risks, including falls and crush hazards. Ensure personnel understand and are appropriately trained in the rescuing procedures. Site based personnel trained in operation of functions and in the emergency lowering systems from the ground control box should be present.
- Assess other alternative work methods or equipment before operating near a steep slope. If the machine must be placed near an edge or steep slope, ensure barriers are available to support the weight of the machine. Take into consideration the machine's stopping distance. If this is not possible, evaluate and establish the placement of machine and sequence of operations so that the aerial work platform can operate in a safe manner (e.g. machine is in line with the edge rather than towards the edge).

Extra care must be taken if aerial work platforms are used to manoeuvre up through several levels of steelwork. There is a risk of the operator being trapped should the basket strike the steelwork.

This risk increases with the number of steelwork levels and if material is piled up on lower level reducing the spacing between levels.

C - Pre-operation inspection

3 - Inspection and Functional test

3.1 - DAILY INSPECTION

Each day before the beginning of a new work session and with each change of operator, the machine must be subjected to a visual inspection and a complete functional test.



- Never use a defective or a malfunctioning aerial work platform.
- If any item on the check list is marked "No" during the inspection; machine must be tagged and placed out of service.
- Do not operate the machine until all identified items are corrected and it has been declared safe for operation.

In case of loose fasteners, refer to torque table value in maintenance book.

In case of leaks, replace the damaged part before use.

In case of structural part deformation, cracks, broken weld, paint chips, replace the part before use.

Sample of broken welds

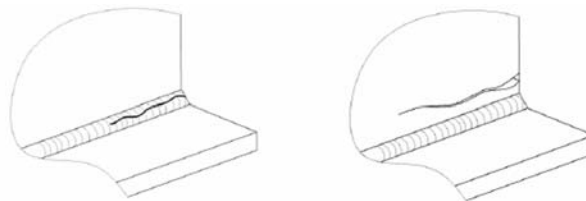

Inspection Forms are provided to assist your inspection process.

We recommend these forms to be completed daily and stored to assist with your maintenance schedule.

Each action is depicted in the daily inspection sheet using the following symbols.

	Visual inspection without disassembly		Lubrication-Grease		Functional adjustments
	Drain		Test and validate		Tighten
	Check levels		Systematic replacement		
	Visual inspection with small disassembly or movement needed to reach the part. Replacement is necessary.		Proof tests : Need HAULOTTE Services® authorization. For countries where machines are not subject to controlled periodic maintenance.		

C - Pre-operation inspection

		Daily inspection				
	Visual inspection without disassembly		Check level			
				To check by test		
		Yes		No	Corrected	Not applicable
Manuals and displays. Clean or replace if necessary.						
	Presence, cleanliness and legibility of the manufacturer's plate					
	Presence, cleanliness and legibility of operator's and maintenance manuals					
	Presence and cleanliness of load chart of the machine					
Control box (Ground and Platform)						
	Presence and cleanliness of the control box					
	No visible damage					
	All decals at the control boxes are clean and legible					
	Operation of start / stop device					
	Operation of E-stop button device					
	Operation of enable switch					
	Operation of horn from platform control box					
	Operation of movement from platform control box					
	Test warning alarm lights and buzzer					
	No abnormal noise and jerky movements from platform control box					
	Joysticks and movement switches return to neutral					
	Presence of the turret pin and its locking device					
	Presence of end stops and their locking system					
Work Platform. Floor, guardrails, access and extensions						
	No cracks, broken weld, paint chipped					
	No deterioration and visible damage					
	Harness anchor points are not cracked or damaged, with the decal attached and legible					
	No screws missing / loose parts					
	Entry bar/gate closes automatically and is not prevented from closing.					
	Folding guard-rail (if fitted) is fixed securely in position					



C - Pre-operation inspection

Extending structure (scissors)					
No cracks, broken weld, paint chipped					
No deterioration and visible damage					
No screws missing / loose parts					
No foreign body in joints or slides					
Presence of securely fitted maintenance devices (safety stand)					
Frame, axle, steering system, scissors ...					
No cracks, broken weld, paint chipped					
No deterioration and visible damage					
No screws missing / loose parts					
No foreign body in joints or slides					
Condition of tires/tyres (wear, cutting, damage ...)					
Wheel reducer is undamaged and operates smoothly					
Correct opening and locking of covers					
Pin, pin stop, bearing ...					
Presence of the turret pin and its locking device					
Presence of end stops and their locking system					
No bent, cracked or broken pins, pin stops, bushes or bearings					
Cylinder and hydraulic component : pumps, filters, manifold					
No leaks on the pump, tank or fittings					
No deformation, visible damage, broken weld or leaks on hydraulic cylinder					
Presence and good condition of hydraulic hose					
No screws missing / loose parts					
Check hydraulic oil level is above the minimum level					
Energy storage : Batteries					
Battery electrolyte level					
No screws missing / loose parts					
Presence and good condition of the batteries: terminations and clamps, electrolyte level ...					
Electric cables					
No torn or split wire sheaths					
No evidence of chemical damage or corrosion on all cables					
No oxidation or corrosion on terminals					

C - Pre-operation inspection

Sensors and safety device					
Slope limiting device operates properly					
Test of load sensing system (visual warning at control box)					
Serial number :	Model :				
Hours of operation :					
HAULOTTE Services® contract reference :					
Intervention record number :	Signature :				
Date :					
Name :					

A

B

C

D

E

F

G

H

I

C - Pre-operation inspection

4 - Safety functional checks

To protect the user and the machine, safety systems prevent the movement of the machine beyond its operating limits. These safety systems when activated immobilize the machine and prevent further movement.

The operator must be familiar with this technology and understand that is not a malfunction but an indication that the machine has reached an operation limit.

Aerial Work platforms are equipped with two control boxes which allow operators to safely use the machine. An auxiliary device (emergency pull-T-handle) is available on the chassis to assist with the emergency lowering of the machine. Each control box is equipped with an E-Stop button, which cuts all movements when pushed in.

The following checks describe the operation of the machine and the specific controls required.

For the location and description of these controls :  refer to section B 3.3 and D 2 Ground panel and B 3.4 and D 3 Platform panel.

4.1 - E-STOP BUTTON CHECK

Ground control box E-stop button

Step	Action
1	Pull the E-stop button (15) at ground.
2	Turn the control box activation key selector (92) to the right to energize the ground control box. The indicators light up.
3	Push the E-stop button (15). The indicator goes out.

Platform control box E-stop button

Step	Action
1	Pull the E-stop push-button (46).
2	Turn the control box activation key selector (92) to the left to energize the platform control box. The indicators light up.
3	Push the E-stop button (46). The indicator goes out.

4.2 - ACTIVATION OF CONTROLS

The enable switch must be active to allow all movements.

The "Enable Switch" system depends on the machine configuration and will consist of one of the following :

- Enable trigger on platform control joystick.
- Foot pedal switch in the basket (Optional).
- Enable switch on the ACTIV'Screen on ground control box.

C - Pre-operation inspection

4.3 - FAULT DETECTOR

The machine is equipped with an on-board fault detection system, which indicates the type of fault to the operator.

The fault is identified by a default code.

The default code is displayed at the ground control box.

According to the type of fault, the machine MAY switch into DOWNGRADEMODE and certain movements are prevented to maintain Operator's safety.

Do not use the machine until the fault has been corrected.

4.3.1 - Buzzers test

From the ground control box

Step	Action
1	Pull the E-Stop buttons (15) at ground control box and (46) on the platform control box
2	Turn the control box activation selector key (92) to the left or right to activate a control box. An audible signal (beep) sounds.

4.4 - OVERLOAD SENSING SYSTEM (IF FITTED)

If the platform load exceeds the maximum allowed load, no movement is possible from the 2 control boxes.

At ground and platform control boxes a buzzer sounds and an indicator light warns the operator

To return the machine to normal operation remove weight from the platform until the load is below the maximum allowed load.

Daily check that the LED's illuminate when the machine is switched on :

- Verify that the Overload system is active : Refer to Indicators (6) at ground and (30) at platform.
- Verify that the buzzers are functioning : Refer to Buzzers test

A periodic inspection of this device must be performed according to the recommendation in Maintenance Schedule.

C - Pre-operation inspection

4.5 - SLOPE WARNING DEVICE

From each control box, a buzzer alerts the operator that the machine is not folded/stowed position and is positioned on a slope exceeding the slope allowed.

N.B.-:THE SLOPE SENSOR IS ONLY ACTIVE WHEN THE PLATFORM IS NOT IN THE STOWED POSITION.

When the unfolded machine is on a slope greater than the rated slope, out of the stowed position, DRIVE and LIFT functions are disabled(For CE and AS only).

All speeds are reduced

In this case, fully lower the platform and reposition the machine on level ground before raising the platform again.

N.B.-:DEPENDING ON YOUR MACHINE CONFIGURATION, OUTSIDE ASSISTANCE MAY BE NECESSARY IN ORDER TO CARRY OUT THIS OPERATION.

To check the tilt sensor at ground control box

Step	Action
1	Pull the E-stop push-buttons on the platform and ground control boxes (46, 15).
2	Switch on the machine from the ground control box (92).
3	Lower the platform completely.
3	Locate the tilt sensor next to the ground control box.
4	Manually tilt and maintain the tilt sensor towards the front for a few seconds ( Section B 3.1 - Layout) :
5	The audible beep sounds.
6	For machines fitted with : The slope sensor prevents lifting and driving movements (Except ANSI and CSA).

4.6 - TRAVEL SPEED LIMITATION

Drive speed is proportional to control, without restriction, until the maximum speed is reached (machine in fully stowed position).

The only speed allowed when not in stowed position is microspeed (This speed is a default speed programed into the machine).

4.7 - ELECTRONIC VARIABLE SPEED DRIVE

The machines are equipped with 2 electronic variable speed regulators configured for each function and manages the required power needed for each motor.



Do not interchange the speed controllers/regulators between machines even if they are the same model..

C - Pre-operation inspection

4.8 - OPERATING TEMPERATURE (FOR RUSSIA AND THE UKRAINE ONLY)

Hydraulic energy to perform machine movements is provided by an electric motor driven hydraulic pump. The operating speed of the pump is governed by a speed regulator. If the temperature limits are reached, an audible alarm alerts the operator. All movements are cut off except getting back to transport position.

Temperature limits :

- from 0° C / 32° F to + 40° C / 104° F

Location of operating temperature thermostat

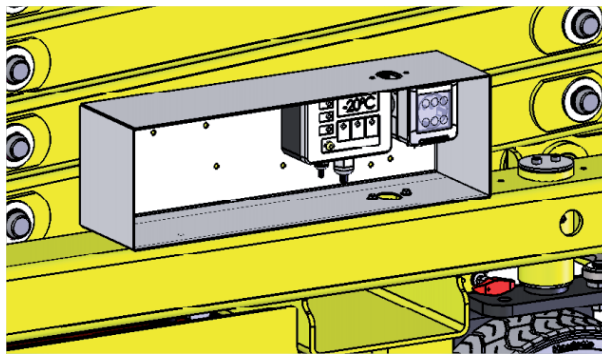

4.9 - MACHINE BRAKING

When electric power is cut off, the machine stops automatically.

Performance levels may be reduced in the following situations :

- Descending a bumpy ramp.
- Worn tires/tyres.
- Damp or muddy ground conditions.

Check that the brakes are applied automatically when the Drive joystick is released to the neutral position.

4.10 - WHEEL MOTOR BRAKE RELEASE

Each time a drive command is activated, electric power releases the brakes.

4.11 - POTHOLE PROTECTION SYSTEM

To reduce the risk of overturning, the machine is equipped with a pothole mechanism under the chassis that is deployed automatically when the platform is out of the stowed position .

C - Pre-operation inspection

4.12 - ON-BOARD CHARGER

Battery charging starts as soon as an external supply is connected to the battery charger.



When the battery pack is being charged with an external power supply, the machine's electric system is automatically deactivated.

4.12.1 - Battery charge level

The indicator (93) shows the charge status of the battery whilst charging :

- Green indicator : Battery charged 100 %.
- Yellow LED : Battery charged 80 %.
- Red LED : Battery in initial charging phase.



4.13 - ANTI-CRUSH SYSTEM WHEN LOWERING

A device alerts people on the ground of a risk of crushing :

- Between the lifting systems.
- Under platform extension.

This device automatically operates between the transport height position limit and the lower position (Refer to Driving speed)

All versions, lowering control from the platform and ground control boxes :

- Slows the downward movement and emits an audible signal.

Standard CE, lowering movement from platform control box :

- The downward movement is delayed for at least 3s (seconds) at the established transport height limit before resuming the descent.

D - Operation instructions

1 - Operation

1.1 - INTRODUCTION

Aerial Work platforms are equipped with two control boxes which allow operators to safely use the machine.

An auxiliary device (emergency pull-knob) is available on the chassis to assist with the emergency rescue of people.

Each control box is equipped with an E-Stop button, which allows operators to stop all movements, if necessary.

Only trained and authorized personnel shall be permitted to operate this aerial work platform.

Prior to operation :

- Read, understand and obey all instructions and safety precautions in this manual and attached to the aerial work platform.
- Read, understand and obey all Federal, State and local codes and regulations.
- Become familiar with the proper use of all controls and emergency systems.

1.2 - OPERATION FROM THE GROUND CONTROL BOX

- Turning "ON" and "OFF" of the machine is performed with selector key switch (92).
- Activation of a desired control box is achieved by turning the control box energizing selector switch (92) to the desired position.
- The ground control box is energized and is active ONLY when :
 - The E-stop buttons on both ground and platform control boxes are not pressed in.
 - The machine is switched on.
 - Ground control box is selected.
- An E-stop button at each control box stops all movements when pressed in (deactivated).

N.B.-:-AN E-STOP BUTTON PRESSED IN DOES NOT TURN OFF THE MAIN POWER SUPPLY TO THE MACHINE.

- An enable switch (9) provided must be activated and maintained to authorize one or more function movements. If enable switch (9) is kept engaged without selecting a function movement for more than 8 s; enable switch is automatically de-activated.
- The release of "Enable switch" (9) while performing a movement stops all the movements. The stop of movements is progressive. If the "Enable switch" system is re-pressed, the movement doesn't restart. It could restart only when the selected function switch/joystick is released to neutral position.
- All switches and joystick operating a movement, return automatically to neutral when released.
- At power up, a switch in it's neutral position will be taken into account to authorize movement.
- The ground control box is designed for maintenance and emergency rescue operations only. Refer to  Section D 4.2 To rescue operator in platform.

D - Operation instructions

- The status of the switches is tested automatically when the machine is switched on, and checked at every starting. A switch will be active only after it has been detected to be in neutral position. The following switches are not controlled :

- Beacon light (if fitted)

A buzzer beeps in the following conditions :

- Overload (if fitted).
- Machine out of stowed position and on a slope greater than allowable slope.
- Hydraulic oil overheating.
- Movements option.
- Indicators / Cluster : All indicators are checked after powering on the machine

1.3 - OPERATION FROM THE PLATFORM CONTROL BOX

- The platform control box can only be used if :
 - The E-stop buttons on both ground and platform control boxes are not pressed in (Energized).
 - Machine switched on at ground control box.
 - Platform control box selected from ground control box.
- A faulty joystick is not taken into account to control a movement. If this fault disappears, the movement is authorised again.
- An E-Stop button is present at each control box. When pushed in, it stops all functions movements and will shut off the engine (if equipped).
- An "Enable switch" (123) (foot pedal switch in the basket) is present and should be activated to authorize one or more function movements. If the enable switch is kept active for more than 8 seconds without selecting a function movement, then movement is disallowed. The enable switch must be released (reset) before movement can occur.
- The release of "Enable switch" (123) while performing a movement stops all the movements. The stop of movements is progressive. If the "Enable switch" is pressed again quickly within 0,5 s the movement restarts. If the "Enable switch" is not pressed again quickly enough within + 0,5 s the movement will not restart. It could restart only when the selected function switch/joystick is released to neutral position.
- All switches and joystick operating a movement, return automatically to neutral when released.
- At power up, a switch in it's neutral position will be taken into account to authorize movement.
- The status of the switches is tested automatically when the machine is switched on, and checked at every starting. A switch or joystick will be active only after it has been detected in neutral position.

D - Operation instructions

A buzzer beeps in the following conditions :

- Overload (if fitted).
- Machine out of stowed position and on a slope greater than allowable slope.
- Indicators - All the indicators are tested
 - When the machine is switched on.

A

B

C

D

E

F

G

H

I

D - Operation instructions

2 - Ground control box

2.1 - TO START AND STOP THE MACHINE

- Ensure that the E-Stop buttons (15) and (46) at the ground and platform control boxes are pulled out.
- Turn the key of the control box activation selector (92) to the right to energize the ground control box.

To shut-down the machine from the ground control box :

- Turn the control box activation selector (92) key to the center.
- Push in the E-stop button (15).



2.2 - MOVEMENT CONTROL



Even at low movement speeds, use the controls with caution.

N.B.-:-RELEASING THE ENABLE SWITCH WILL STOP ALL MOVEMENTS.

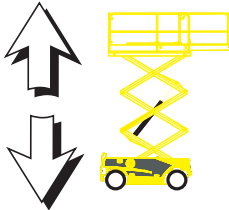
Ground box controls (emergency station)

Control	Action
Platform raising / lowering 	Push the platform raising / lowering selector (106) upwards to raise the platform. <hr/> Press the platform raising / lowering selector (106) downwards to lower the platform.
Emergency lowering / Emergency platform lowering halted 	Pull the emergency handle (C107) to lower the platform. <hr/> Release the emergency handle (C107) to stop platform lowering.



Once rescue operations are complete, write an incident report.

D - Operation instructions

Pull T-handle for emergency lowering



N.B.:-PULLING ON TO THE PULL T HANDLE, IMMEDIATELY ACTIVATES THE EMERGENCY LOWERING OF THE PLATFORM.



ALWAYS keep personnel and obstructions clear of the aerial work platform that might block the lowering.

2.3 - ADDITIONAL CONTROLS FROM THE GROUND CONTROL BOX

For the machines equipped with beacon light :

- Push the beacon light selector switch (105) upwards to turn ON the beacon light.
- Push the beacon light selector switch (105) downwards to turn OFF the beacon light.

D - Operation instructions

3 - Platform control box

3.1 - TO START AND STOP THE MACHINE

To start the machine :

At the ground control box :

- The E-stop button on the ground control box must be in ON position (pulled out / activated).
- Turn the key on the control box activation selector switch (92) to the left to energize the platform control box.

At the platform control box :

- Pull the E-stop button (46).

To stop the machine :

- Push in the E-stop button (46).

3.2 - DRIVE AND STEER CONTROL

To control the direction and drive :

- Move the 2-position selector (112) to the right.
- The drive indicator (111) lights up.
- Simultaneously operate drive joystick (108) with joystick trigger (Enable switch (123)) pressed in and maintained

N.B.-:-THE ENABLE SWITCH (123) IS THE FOOT PEDAL FOR ANSI AND CSA STANDARDS ONLY.

N.B.-:-THE DRIVE AND LIFT SPEEDS ARE PROPORTIONAL TO THE POSITION OF THE JOYSTICK. PUSHING THE JOYSTICK COMPLETELY FORWARD OR BACKWARD, WILL RESULT IN MAXIMUM SPEED.

Control		Action
Driving		Move the drive joystick (108) forwards to drive the machine forwards.
		Move the drive joystick (108) backwards to drive in reverse.
Front-axle steering		Push the front-axle steering selector thumb switch (108) to the right to steer to the right.
		Push the front-axle steering selector thumb switch (108) to the left to steer to the left.

D - Operation instructions

3.3 - MOVEMENT CONTROL

To operate raising/lowering function, move 2 position selector switch (112) to the left. Activate raising/lowering selector (110). Simultaneously operate joystick (108) with joystick trigger (Enable switch (123)) pressed in and maintained.

N.B.-:-THE ENABLE SWITCH (123) IS THE FOOT PEDAL FOR ANSI AND CSA STANDARDS ONLY.

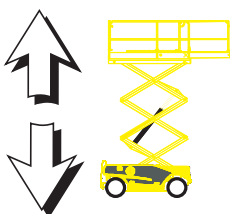
Control	Action
Platform raising / lowering 	Push the movement joystick (108) forwards to raise the platform.
	Push the movement joystick (108) backwards to lower the platform. 1. 2. 3. .

1. When the platform is lowered to a height of 1,50 m(4 ft11 in) from the ground; a time delay is automatically activated for a few seconds, before any further lowering of the platform can commence
2. This is to avoid any risk of crushing
3. The alarm sounds

D - Operation instructions

4 - Emergency procedure

4.1 - IN CASE OF POWER LOSS

In case of loss of the main power source, the secondary (back-up) power unit, powered by the starting battery, allows movements to be controlled from both the ground and platform control boxes.

In an emergency, if the operator has to exit the platform while it is elevated, the transfer of the operator must respect the following recommendations. :

- Exit onto a sturdy and safe structure.
- The occupant(s) must ensure that 2 lanyards are used for security/safety. One must be attached to the designated anchorage point on platform the occupant(s) is in and the other attached to the structure intended to get on.
- Occupant(s) must exit the current platform through the normal access.

N.B.-:DO NOT DETACH THE LANYARD FROM THE CURRENT PLATFORM IF THE TRANSFER TO THE NEW STRUCTURE POSES ANY DANGER OR UNTIL THE TRANSFER IS SAFELY COMPLETED. DO NOT ATTEMPT TO CLIMB DOWN FROM THE PLATFORM. WAIT FOR ASSISTANCE TO LEAVE THE CRADLE SAFELY.

4.2 - TO RESCUE OPERATOR IN PLATFORM

In a situation where an operator located in the platform needs to be rescued (for example in case of illness, injury or trapped against a structure making the control box inaccessible), the rescue personnel at ground level needs to obtain rapid and direct access to operating functions.

HAULOTTE® provides a ground control emergency system that should be used to safely bring the operator into such a position that appropriate medical attention could be provided.

Lower the platform using the emergency pull T-handle on the chassis.



Once rescue operations are complete, write an incident report.

Or :

1. Turn the key of the control box activation selector (92) to the right to energize the ground control box. The platform box controls are de-energized.
2. Lower the platform from the ground control box.
3. Lower the platform using the platform raising/lowering selector (1) while simultaneously pressing and maintaining the "Enable switch" (9).
4. Release it to halt lowering.

D - Operation instructions

5 - Transportation

5.1 - PUTTING IN TRANSPORT POSITION

To avoid any risk of machine movement during loading, ensure that :

- The loading ramp can support the machine weight.
- The loading ramp is correctly attached to transport vehicle.
- The loading ramp has sufficient grip surface.
- The transport vehicle must be parked on a level surface and must be secured to prevent rolling away while machine is being loaded or unloaded.

To climb the slope, move progressively the drive joystick (108).

If the slope is too steep, use a winch in addition to traction.

Do not place yourself below or too close to the machine during loading.

A wrong move can lead to machine tipping over and may cause serious injuries and material damage.

The machine must be completely in the stowed configuration :

- Check the platform is completely empty.
- Drive the machine onto the truck bed.
- Secure the machine to the tie down points provided (See picture).
- The covers must be locked.



Do not use excessive downward force when securing platform/basket.

D - Operation instructions

5.2 - MACHINE LAYOUT

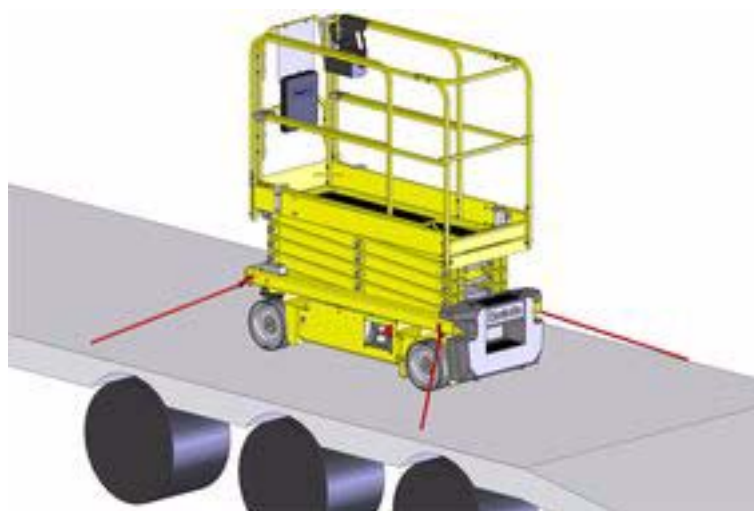

5.3 - UNLOADING

Before unloading, check that the machine is in good condition.

- Remove the tie downs.
- At ground control box turn control box activation switch (92) to the left to energize platform box.
- At the platform controls, with 2 position selector (112) turned to the right, carefully and progressively move drive joystick (108) with Enable switch (123) pressed and maintained.



Warning : Upon starting a machine that has been secured and transported, the safety system may detect a false overload preventing all movement from the platform control box.

To reinstate the system, lift the platform a few centimetres (inches) from the ground control box.

D - Operation instructions

5.4 - TOWING



In the event of a machine breakdown, the machine can be towed a short distance to load it onto a transport vehicle :

- Ensure that no one is in the platform during towing.
- Before towing, ensure that the platform is fully lowered.
- The platform must be empty.
- **ALWAYS** keep personnel and obstructions clear of the aerial work platform when brakes are released.

To tow a broken-down machine, release brake (Refer to  Section D 5.4.1 Brake release). Perform this operation on flat ground with wheels chocked.

In the towing configuration, the machine braking system is inactive. Use a drawbar to avoid any risk of accident :

- Do not exceed the maximum speed (machine unfolded) (Refer to  Section B 4 Technical specifications).
- Do not exceed a grade of 25%.

A

B

C

D

E

F

G

H

I

D - Operation instructions

5.4.1 - Free wheel mode

To tow a broken-down machine, release brake.



Perform these operations on flat, horizontal ground. Failing that, block the wheels to immobilize the machine. During brake release operation, the machine is in free wheel mode and the brake system no longer functions.

If the machine is towed, the brakes on the drive wheels can be released using the switch located in the motor pump unit compartment.

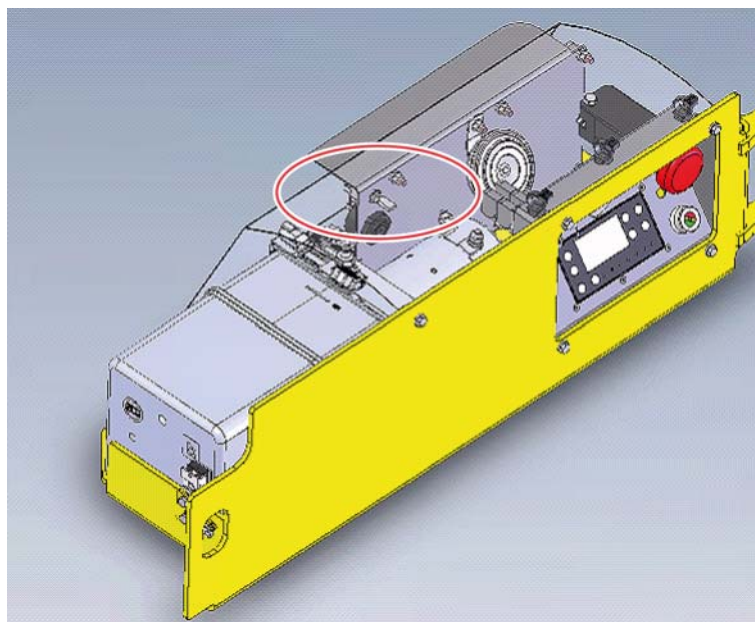

To release the machine's brakes, the following conditions must be met :

- The platform control box or the ground control box must be selected.
- The machine must be completely stowed.
- No movement selected.
- The machine must not be tilted.

Push the brake release button for at least 3 s. An audible signal (beep) sounds.

Releasing the button disengages the brakes.

The brake release procedure stops automatically if the brake release button is pushed again, any actions are taken at the control boxes, the machine is turned off, or the control box in use is changed.



In the towing configuration, the machine is no longer slowed down. Use a drawbar to avoid any risk of accident.



Do not exceed 5 km/h (3,10 mph) .

D - Operation instructions

5.5 - STORAGE

When the machine is stored with platform raised, it is necessary to regularly switch "ON" the power to ensure that the security systems are active..

It is recommended that the machine is not stored or immobilized unfolded; to avoid jeopardizing the safety of people and property.

Ensure all access panels, doors and side compartment covers are shut and secured.

Turn the energizing key selector switch (92) at the ground control box to the "center" position to shut OFF the power.

Remove the key switch to prevent unauthorized operation of the machine.



Storing of the machine with an obstacle under the extended platform is forbidden.



When machine is stored and not used for more than 1 week, check the battery's state of charge, recharge if necessary.

5.6 - LOADING BY RAMP



To avoid any risk of sliding during loading, ensure that :

- The loading ramp can bear the load.
- The loading ramp is correctly attached.
- The loading ramp has sufficient grip.



If the slope exceeds 25% grade, use a winch to assist in loading on to the ramp.



Never place yourself below or too close to the machine during loading.

A wrong move can lead to the tipping over of the machine and cause serious bodily and material accidents.

5.7 - UNLOADING BY RAMP



Before operating, check that the machine is in good condition.

If the machine has been damaged during transportation, contact the transporter in writing

1. Remove the tie downs.
2. Start the machine.
3. The ramp is in good condition and of sufficient capacity. The lifting equipment ie. slings, shackles, hooks, lifting beam etc. are in good condition and of sufficient capacity.

D - Operation instructions

5.8 - LIFTING OPERATION

During loading / unloading operation, if it becomes necessary to lift the machine using an overhead crane, it is important to respect the following :

- Put the machine in stowed position (Extension retracted).
- Ensure the platform is empty.
- Verify that lifting accessories are in good operation and match the technical specifications listed below. It is important that the lifting devices are attached only to the designated lifting eyes.
- Each of the chains/slings used for lifting the machine must be adjusted to keep the machine level and to minimize the risk of damage to the machine.



- Anchorage point for lifting are identified / labeled by the following symbol
- ONLY trained and authorized personnel should attempt to lift the machine.



Never lift the machine with slings attached to counterweight.

Procedure for the use of slings



Number of shackles	Number of slings	Length	Maximum load per sling and shackle
4	4	2 m / 6 ft 7 in	1000 kg / 2,205 lbs

D - Operation instructions

5.9 - LOADING AND UNLOADING WITH FORKLIFT

- Lower the platform.



The machine must be in the fully stowed transport position.

- Ensure that the machine controls are in the OFF position.
- Forklift used to load and unload must have adequate capacity (Refer to  Section B 4 Technical specifications).
- Adjust the forklift forks spread to match with the machine fork pockets.
- Carefully insert the forklift forks in the designated machine fork pockets.



Never place yourself below or too close to the machine during loading.

A wrong move can lead to machine tipping over and may cause serious injuries and material damage.

Unloading

- Carefully lift the machine and make sure that the machine weight is properly balanced.
- Slowly lower the machine and place it on the ground.

D - Operation instructions

6 - Cold Weather Recommendations

N.B.:-INITIAL STARTING SHOULD ALWAYS BE PERFORMED FROM THE GROUND CONTROL BOX.

6.1 - HYDRAULIC OIL

External environmental conditions can reduce performance of the machine if the hydraulic oil temperature does not reach its optimum range.

It is recommended to use the hydraulic oil according to weather condition. Refer to the table below.

Environmental conditions	SAE Viscosity grade
Ambient temperature between - 15°C (5°F) and + 40°C (+ 104°F)	HV 46
Ambient temperature between - 35°C (- 31°F) and + 35°C (+ 95°F)	HV 32
Ambient temperature between 0°C (+ 32°F) and + 45°C (+ 113°F)	HV 68

N.B.:-IT IS RECOMMENDED TO REPLACE LOW TEMPERATURE OIL AS THE AMBIENT TEMPERATURE REACHES + 15°C (59°F). IT IS NOT ADVISABLE TO MIX OILS OF DIFFERENT BRANDS OR TYPES.

D - Operation instructions

7 - Battery care and maintenance

7.1 - BATTERY CHARGING

Recharge aerial work platform batteries after each 8 hour work shift or as needed. When the aerial work platform is not in use, batteries should be recharged at least once per week. Under normal circumstances, battery recharge should take approximately 8-10 hours. However, a full recharge may take up to 24 hours, if the battery charge is extremely low.

Battery charger status

Ground control box :

The indicator (93) indicates charge status.

- Green indicator : Battery charged 100 %.
- Yellow LED : Battery charged 80 %.
- Red LED : Battery in initial charging phase.



Platform control box :

The indicator (91) indicates charge status.

- Battery charged :
- Flashing : Batteries have 40% charge left :
- Constantly on : Batteries have only 20% charge left :

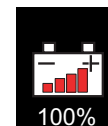

D - Operation instructions

When should the batteries be charged? :

- Never discharge the batteries to more than 80 % of their capacity in 5 h (hours).
- When the batteries are discharged to between 35 % and 80 % of their nominal capacity.
- If installing new batteries, recharge them after 3 or 4 hours of use 3 to 5 times
- After a long period of non-use.
- Never leave the batteries discharged.
- Do not put off recharging the batteries in cold weather as the electrolyte may freeze.



- Do not recharge the batteries if the temperature of the electrolyte exceeds 40 °C(104 °F) . Allow to cool down.
- Keep the top of the batteries clean and dry. Incorrect connection or corrosion may cause a high loss of power
- The charger settings are adjusted in the factory using its own cable. If the cable needs changing, the HAULOTTE® factory must be contacted to obtain authorisation.

How to charge the batteries ? :



Before charging the batteries, switch the machine off.

- Use the machine's on-board charger. The charger has a charge rate compatible to the battery capacity.
- Ensure that the mains supply is compatible to the charger's consumption.
- Top up the batteries with distilled water to the minimum electrolyte level if any of the elements are below this minimum level.
- Work in a clean and well-ventilated area away from naked flames.
- Move the aerial work platform to a well-ventilated area with direct access to a AC electrical outlet.

Charger type	24 V - 20 Ah
Electric power supply	220 V single phase 50 Hz 120 V single phase 60 Hz 80 V single phase 50 - 60 Hz
System voltage	24 V
Charging time	Approximately 10 h for batteries discharged to 80 %

D - Operation instructions

To recharge the aerial work platform batteries :

Attach a 12 AWG multi-strand, grounded extension cord with a maximum length of 15 m (50 ft) to the receptacle located on the charger.

Plug the extension cord into outlet.

Start-up is automatic as soon as the mains connection is established. The charger is fitted with a LED indicator placed near the special holding frame :

- Green indicator : Battery charged 100 %
- Yellow LED : Battery charged 80 %
- Red LED : Charger in the initial charge phase

The CHARGING indicator LED remains lit continuously during the first stage of the charge cycle. The charge current will be displayed on the BATTERY CHARGER FACEPLATE.

To display the Battery Voltage, press (push) in and hold the BATTERY VOLTAGE button.



Do not disconnect any output leads or connectors between the batteries and the charger when the charger is on. To stop a charge in progress, always unplug the extension cord from the AC power source.



Recharge batteries in a well-ventilated area only. Do not charge batteries near fire, spark or other potential ignition sources. Batteries may emit highly explosive hydrogen gas while charging. Failure to properly ventilate the charge gasses could result in death or serious injury. Always charge aerial work platform batteries away from flammable materials.

When the battery charge reaches 80% of capacity, the yellow 80% CHARGED indicator LED will become lit and the green CHARGING indicator LED will begin to flash.

Unplug the extension cord from the outlet and the charger receptacle on the aerial work platform. Store the extension cord for next use.

N.B.-:ALWAYS UNPLUG THE BATTERY CHARGER POWER CORD BEFORE MOVING THE AERIAL WORK PLATFORM. FAILURE TO DISCONNECT POWER CORD COULD CAUSE DAMAGE TO THE EQUIPMENT.

E - General Specifications

1 - Machine dimensions

Stowed / Transport position : Configuration that takes the minimum floor space necessary for storage and / or delivery of the machine - Access position.

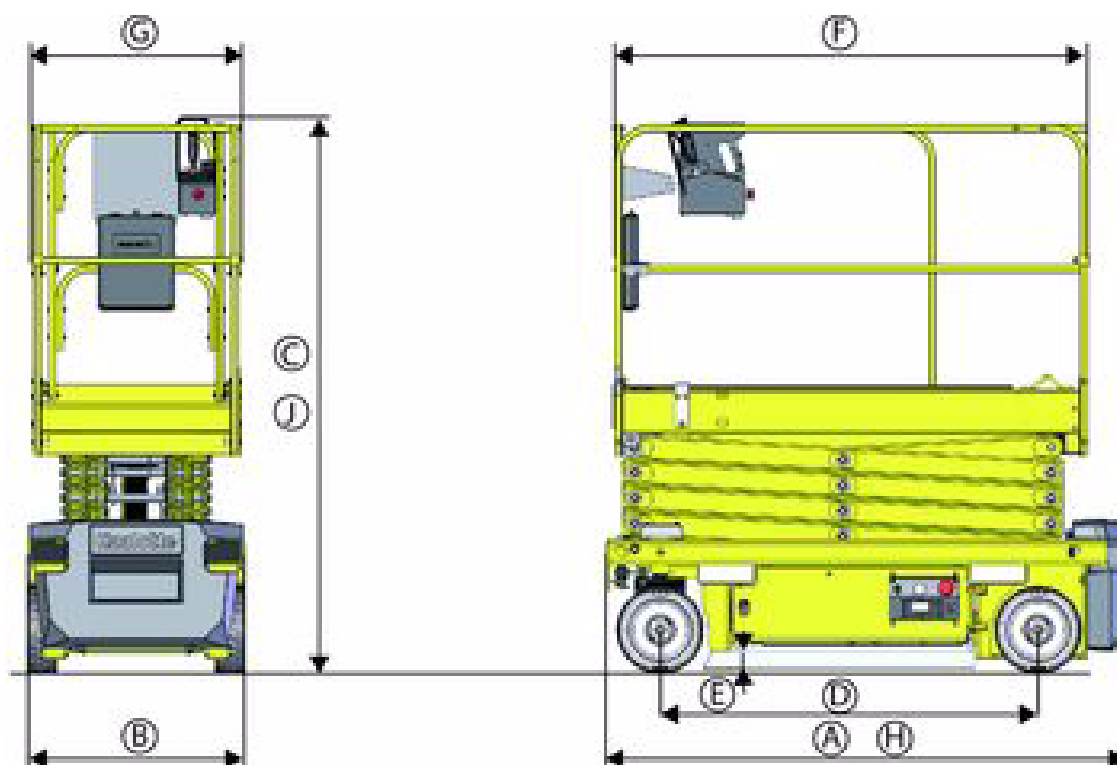

CE and AS standards

Machine		OPTIMUM 8	
Marking	Specifications - Dimensions	SI	Imp.
A	Overall length of machine	1,89 m	6 ft 2 in
B	Overall width of machine	0,79 m	2 ft 7 in
C	Overall height of machine	1,99 m	6 ft 6 in
D	Wheel base	1,38 m	4 ft 6 in
E	Ground clearance - Pothole mechanism deployed with platform raised	2,2 cm	1 in
	Ground clearance - Pothole mechanism retracted with platform fully lowered	6 cm	3 in
F X G	Platform dimensions	1,73 m x 0,74 m	5 ft 8 in x 2 ft 5 in
H	Storage length	1,89 m	6 ft 2 in
J	Storage height	1,99 m	6 ft 6 in

E - General Specifications

ANSI and CSA standards

Machine		OPTIMUM 1931 E	
Marking	Specifications - Dimensions	SI	Imp.
A	Overall length of machine	1,89 m	6 ft 2 in
B	Overall width of machine	0,79 m	2 ft 7 in
C	Overall height of machine	1,99 m	6 ft 6 in
D	Wheel base	1,38 m	4 ft 6 in
E	Ground clearance - Pothole mechanism deployed with platform raised	2,2 cm	1 in
	Ground clearance - Pothole mechanism retracted with platform fully lowered	6 cm	3 in
F X G	Platform dimensions	1,73 m x 0,74 m	5 ft 8 in x 2 ft 5 in
H	Storage length	1,89 m	6 ft 2 in
J	Storage height	1,99 m	6 ft 6 in

2 - Major component masses

Specifications	OPTIMUM 8	OPTIMUM 1931 E
	SI	Imp.
Frame assembly mass	948 kg	2090 lbs
Scissors assembly mass	430 kg	948 lbs
Platform assembly mass	125 kg	276 lbs
Drive wheel mass	19 kg	42 lbs
Steer wheel mass	19 kg	42 lbs
Central counterweight mass	248 kg	547 lbs
Footboard counterweight mass	244 kg	538 lbs

3 - Acoustics and vibrations

The acoustics and vibrations specifications are based upon the following conditions :

- The airborne noise emissions at workstation are determined per European Directive 2006/42/CE.
- The guaranteed sound power level LWA (displayed on the product) is determined per European Directive 2000/14/CE.
- The vibrations transmitted by the machinery to the hand/arm system and to the whole body are determined per European Directive 2006/42/CE.

Specifications	
Sound pressure level at workstation	63 dBA
Vibrations hand/arm	Vibration transmitted by this MEWP to the hand-arm does not exceed 2,5 m/s ² (98,4 in/s ²)
Vibrations whole body	Vibration transmitted by this MEWP to the whole body does not exceed 0,5 m/s ² (19,6 in/s ²)

E - General Specifications

4 - Wheel/Tire assembly

4.1 - TECHNICAL SPECIFICATIONS

Component	Standard wheel
Reference number	Solideal
Type	Solid tires/tyres
Size	316 mm / 108 mm (12,5 in/ 4,25 in)
Torque	115 Nm (84.81 ft lbs)

4.2 - INSPECTION AND MAINTENANCE

Replace the wheels and the tires/tyres if any of the following conditions exist :

- Presence of cracks, damage, deformation or other faults on the hub
- Damage to the tire :
- Cut or hole > 3 cm (2 in) in the rubber side wall.
- Blister or pronounced lump on the external and lateral wall.
- Damaged wheel stud.
- Damage or wear on the side wall to the extent that the reinforcing wire is visible.
- Consistent wear of the ground contact surface greater than 25%

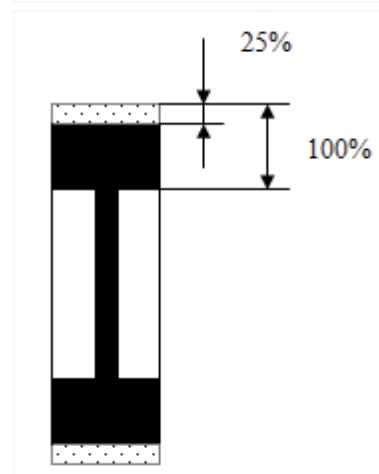
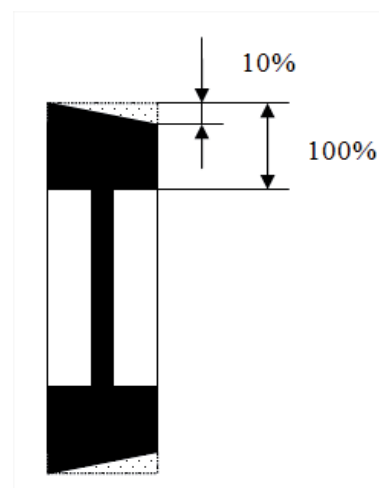

Tires and rims are critical components for the stability of the machine. For safety reasons :

- Use only HAULOTTE® spare parts according to the technical characteristics of the machine. Refer to the spare parts catalog.
- Do not replace factory-installed tires with tires of different specifications or ply rating.

E - General Specifications

Procedure of replacement :

- Loosen the wheel nut on the wheel to be removed.
- Raise the machine using a jack or a hoist.
- Remove the wheel nut.
- Remove the wheel.
- Install the new wheel.
- Lower the machine to the ground.
- Tighten the wheel nut to the recommended torque. Refer to maintenance and repair manuals.

E - General Specifications

5 - Options

5.1 - PLUMBER'S KIT

5.1.1 - Description

This attachment is an assembly designed to transport bars and tubes. The assembly comprises of 2 cradles securely attached to the platform. The load (material) should be placed in both the cradles and secured with a strap (not supplied)

5.1.2 - Characteristics

Specifications	OPTIMUM 8	OPTIMUM 1931 E
	SI	Imp.
Weight of the carrier	9 kg	20 lbs
Weight of the equipment on the carrier	50 kg	110 lbs
Maximum load surface	0,3 m ² (Ø 0,2 m x 1,5 m)	3.3 sq.ft (Ø 8 in x 4 ft 11 in)
Maximum wind speed allowed	0 m/s - 0 km/h	0 mph

5.1.3 - Safety precautions



- Please read and assimilate the instructions before using the attachment.
- This attachment is designed for transporting pipes and tubes. Do not use this attachment for transporting other types of load. .
- Do not suspend loads.
- Do not overload the attachment and ensure that the equipment is correctly attached by means of a strap supplied.
- Do not exceed the maximum allowable platform capacity. The combined weight of the attachment, load, the occupants, the tools and any other equipment must not exceed the maximum allowable platform capacity.
- Do not load tubes whose surface area exceeds the maximum authorized surface area. Exposing an additional surface area to the wind reduces machine stability. Do not install any other attachments that increase the surface area exposed to the wind.
- Do not use the machine if the wind speed exceeds the authorized limit of the attachment.
- The cradles should always be positioned on side of platform control box.
- When maneuvering, ensure you maintain a safe distance between the load and the obstacles in the work environment.

E - General Specifications

5.1.4 - Pre-operation inspection



- Check that the cradles have no cracks or other damage.
- Check that the cradles are correctly installed and secured to the platform (Ensure fastening screws are tightened and pins correctly positioned).
- Check that the information decal is present on the cradle and is legible.
- Check that the strap(s) is(are)not twisted or torn.
- Check that the position of the load and attachment is not obstructing access to the platform or the controls.
- Check that the position of the attachment and the load is not reducing visibility during maneuvers in the work environment.

5.1.5 - Operation

- Position and centre the load to rest on the 2 cradles.
- Securely attach the load to each cradle with supplied straps.

Strapping example(s)

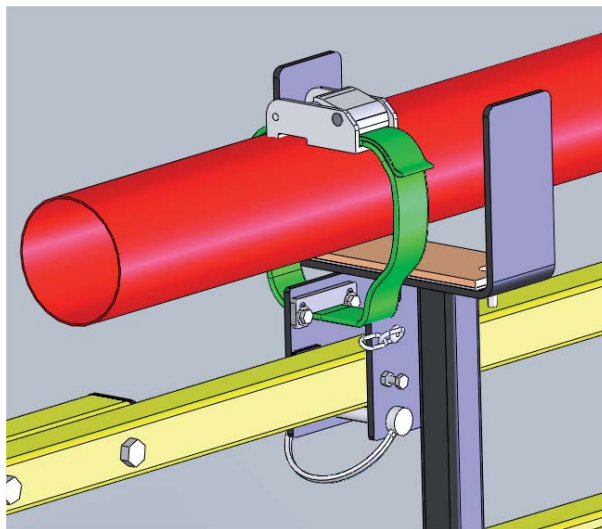

E - General Specifications

5.1.6 - Disassembly - Assembly

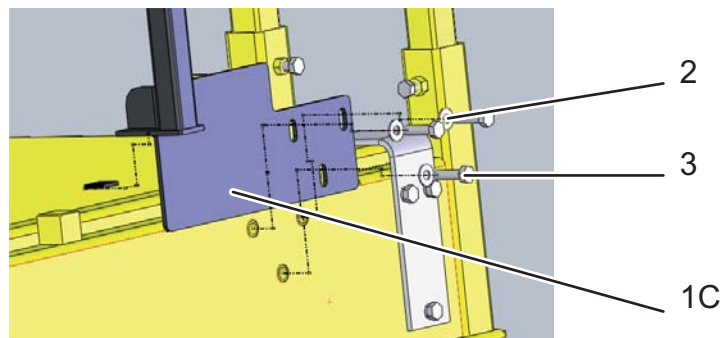
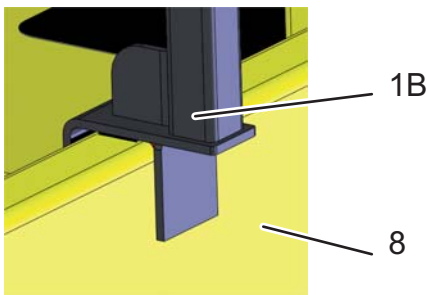
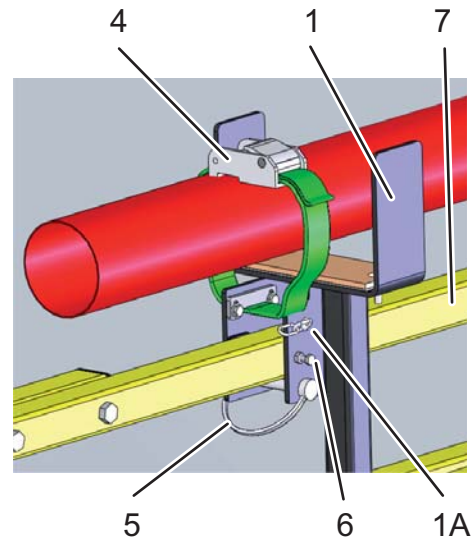
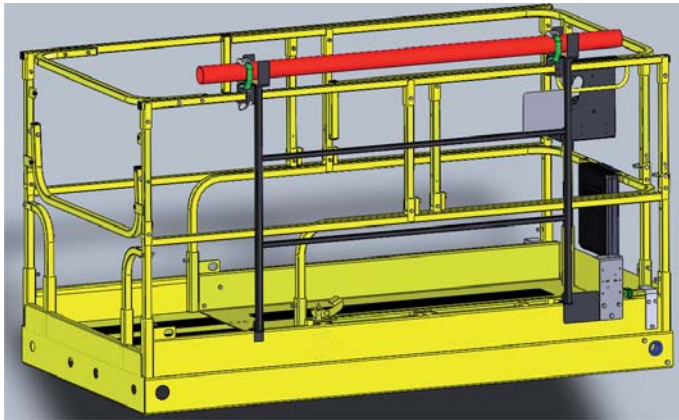

Marking	Description
1 - 1A - 1B - 1C	Carrier
2	Spring washer
3	Fastening screw
4	Strap
5	Dowel pin
6	Adjustment screw
7	Guardrail
8	Platform

- Straddle the support pipes (1, 1A, 1B) and (1C) on the structure of the fixed or folding guard rails (7).
- Lock in place with the pin (5).
- Tighten the 3 screws (3) and 3 washers (2) to the recommended torque

N.B.-:-TORQUE REQUIREMENTS : 22 NM (16 FT LBS)

- **Pre-operation test** : Place and secure the load of 50 kg (110 lbs) max. on the cradles. Ensure that the cradles can support the load and that there is no visual structural damage.

E - General Specifications

5.1.7 - Specific decals

Location of the decals

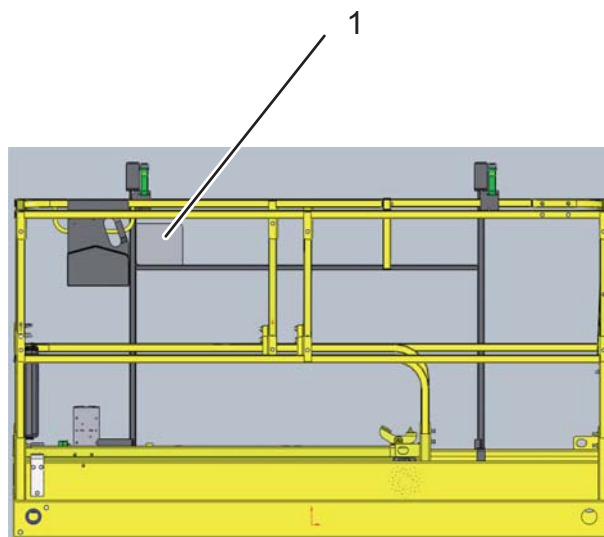

Marking	Description	Quantity	Part number
1	Risk of overturning	1	In english - ANSI : 4000317600 In french - ANSI : 4000317630 In spanish - ANSI: 4000317620

F - Maintenance

1 - General

As an owner and/or operator of Haulotte equipment, your Safety is of utmost importance to HAULOTTE®, which is why HAULOTTE® places such a high priority on product safety.

INSPECTIONS are not only required by HAULOTTE®, but may also be required by industry standards and/or governmental regulations.

To ensure that your equipment continues to perform to the factory set performance levels, it is important that you regularly maintain your equipment and avoid making any modifications that are not approved by HAULOTTE®. Regular and timely inspections will reduce equipment down time as well as prevent possible injury.

N.B.: -DO NOT OPERATE UNLESS YOU ARE FAMILIAR AND TRAINED IN THE PRINCIPLES OF SAFE MACHINE OPERATION.

Overview :

- Walk-around inspections take only a few minutes at the beginning and end of each shift – one of the best ways to prevent mechanical problems and safety hazards.

What to Do :

- Use your senses: sight, smell, hearing and touch.

Frequency :

- Check your machine periodically during your entire workday.
- Make sure to do your inspection the same way every time.
- Complete one of these inspections at the start and end of each shift.

N.B.: -IF DAMAGE OR UNAUTHORIZED MODIFICATIONS ARE DISCOVERED, THE MACHINE MUST BE REMOVED FROM SERVICE UNTIL REPAIRS ARE MADE BY A QUALIFIED SERVICE TECHNICIAN.

It is the owner's responsibility to ensure the required maintenance as recommended by Haulotte is completed prior to the operation of the machine.

If regular maintenance is not carried out, this may :

- Void the warranty.
- Cause machine malfunction.
- Reduce machine reliability and shorten its service life.
- Jeopardize operator safety.

HAULOTTE Services® technicians are specially trained to carry out extensive repairs, interventions or adjustments on the safety systems or elements of HAULOTTE® machines. They carry genuine HAULOTTE spare parts and tools as required, and also provide fully documented reports on all work completed.

The inspection and maintenance table, identifies the role and the responsibilities of each party in periodical machine maintenance.  Section C 4 Inspection and Functional test.

F - Maintenance

2 - Maintenance Schedule

This section provides the necessary information needed to place the machine in safe operation. For maximum service life and safe operation, ensure that all the necessary inspections and maintenance have been completed. There are a number of factors which can affect the design life including but not limited to, severity of operating conditions/routine maintenance which should be carried out in accordance with this manual.

Severity of operating conditions may require a reduction in time between maintenance periods. Machines that have been out of service for more than 3 months must undergo a periodic inspection before the machine is put back into service.

Maintenance must be carried out by a competent company or person familiar with mechanical procedures.

Maintenance operations performed must be recorded in a register / log book of the machine.

F - Maintenance

3 - Inspection program

3.1 - GENERAL PROGRAM

The machine must be inspected on a regular basis at intervals of no less than once 1 per year. The purpose of the inspection is to detect any defect which could lead to an accident during routine use of the machine. Local standards and regulations may require more frequent inspections.

HAULOTTE® requires Reinforced and Major Inspections to be carried out on the product to extend its service life.

Inspections must be carried out by a competent company or person.

The inspection results must be recorded in the safety register or machine log book controlled and overseen by the company manager. This register or machine log book and the list of competent repair persons must be made available to the government work inspector and HAULOTTE Services®.

When	Responsible	Stakeholder	What
Before sale	Owner (or renter)	Competent technician or qualified technician HAULOTTE Services®	Periodic inspection
Before rent	Owner (or renter)	Competent technician or qualified technician HAULOTTE Services®	Daily inspection
Before use or every change of user	User	User	
Annually (1 year)	Owner (or renter)	Competent technician or qualified technician HAULOTTE Services®	Periodic inspection
5 years	Owner (or renter)	Qualified technician HAULOTTE Services®	Reinforced inspection
10 years	Owner (or renter)	Qualified technician HAULOTTE Services®	Major inspection

F - Maintenance

3.2 - DAILY INSPECTION

The Daily inspection includes a visual inspection, operational checks and testing of the safety systems. This must be conducted by the operator before using the machine.

This inspection is the responsibility of the user.

3.3 - PERIODIC INSPECTION

The Periodic inspection is a thorough evaluation of the operation and safety features of the machine.

It must be conducted before the sale / resale of the machine and/or at least once 1 every year.

Local regulations may have specific requirements on frequency, and content of inspections.

The severity of operating conditions may require frequent inspections.

This inspection is the responsibility of the owner, and inspections must be carried out by a competent company or person.

This inspection is in addition to the daily inspection.

This inspection should also be conducted after :

- Extensive dismantling and reassembly of major components.
- Repairs involving the machine's essential components.
- Any accident causing stress to the machine.

3.4 - REINFORCED INSPECTION

The Reinforced inspection is a thorough evaluation of the machine's structural components, to ensure proper functionality of the machine.

This evaluation must occur at a frequency of 5000 hours or every 5 years.

This inspection is the responsibility of the owner, and it must be conducted by a HAULOTTE Services® technician or by a competent company or person.

This inspection includes :

- Daily inspection
- Periodic inspection

N.B.-:-REFER TO THE MAINTENANCE MANUAL FOR DETAILS.

F - Maintenance

3.5 - MAJOR INSPECTION

The Major inspection is a thorough evaluation of the machine's integrity and proper functioning; after a standard/normal working life of 10 years.

This evaluation must take place after 10 years of operation and then repeated every 5 years thereafter.

The severity of operating conditions may require frequent inspections.

This inspection is the responsibility of the owner, and it must be conducted by a HAULOTTE Services® technician.

This inspection includes :

- Daily inspection
- Periodic inspection
- Reinforced inspection

N.B.-:REFER TO THE MAINTENANCE MANUAL FOR DETAILS.

4 - Repairs and adjustments

Extensive repairs, interventions or adjustments on the safety systems or components must be performed by a HAULOTTE Services® technician. Use original spare parts and components only.

N.B.-:HAULOTTE SERVICES® TECHNICIANS ARE TRAINED PROFESSIONALS TO PERFORM EXTENSIVE REPAIRS, INTERVENTIONS AND ADJUSTMENTS ON THE SAFETY SYSTEMS OR COMPONENTS OF HAULOTTE® MACHINES. THE TECHNICIAN CARRIES GENUINE HAULOTTE® SPARE PARTS AND TOOLS AS REQUIRED, AND ALSO PROVIDES FULLY DOCUMENTED REPORTS ON ALL WORK COMPLETED.

HAULOTTE Services® will not take responsibility for any outcomes resulting from inferior services or repairs performed by other unauthorised personnel.

HAULOTTE® reminds that NO modifications SHALL be carried out without the written permission of HAULOTTE®.

Any unauthorised repairs/modifications will void HAULOTTE® warranty.

With the utmost care to ensure enhanced reliability and greater safety of the HAULOTTE® products, it is pertinent that when a "Service or Safety Bulletin" is issued, action is taken immediately. Once the bulletin has been addressed, make sure that the completed form is submitted to HAULOTTE®.

N.B.-:WHEN DISPOSING OR SCRAPPING THIS MACHINE, PLEASE CONSIDER APPROPRIATE METHODS OF RECYCLING. ANY ITEMS THAT REQUIRE SPECIFIC DISPOSAL ARE LISTED WITH INSTRUCTIONS IN THE MAINTENANCE MANUAL.

G - Other information

1 - Warranty disclosure

1.1 - AFTER SALES SERVICE

Our HAULOTTE Services® After Sales Service is at your disposal throughout your machine's service life to ensure the optimum use of your HAULOTTE product :

- When contacting our After Sales Service, ensure that you provide the machine model and serial number.
- When ordering any consumables or spare parts, please use this manual and the HAULOTTE® Essential catalogue to receive your genuine HAULOTTE® spare parts, your only guarantee of parts interchangeability and correct machine operation.
- If there is an equipment malfunction involving a HAULOTTE® product, then contact HAULOTTE Services® immediately even if the malfunction does not involve material and/or bodily damage.

1.2 - MANUFACTURER'S WARRANTY

1.2.1 - Warranty acceptance

On reception of his machine, the owner or rental company must check the machine's condition and fill out the machine reception slip provided.

1.2.2 - Warranty period

The present warranty is valid for a period of 12 months or up to a maximum of 1000 operating hours for lifting and handling equipment and 2000 operating hours for public works machinery, starting from delivery and terminating when the first limit is reached.

Spare parts are covered by a 6 month warranty.

1.2.3 - Procedure conditions

To benefit from the warranty, the owner or rental company must inform the nearest HAULOTTE® subsidiary or the subsidiary that delivered the machine (the only dealer authorised to carry out an intervention under the manufacturer's warranty agreement) of the defect in writing as quickly as possible.

The subsidiary will decide whether to repair or replace the part that proves to be faulty.

The owner or rental company must present the duly completed maintenance book supplied with the machine as proof that the maintenance operations recommended by the manufacturer have been carried out.

The owner or rental company must ensure that the defect covered by the HAULOTTE® warranty is reported to and acknowledged by the HAULOTTE® subsidiary as rapidly as possible or must report the defect in writing.

Work carried out under the HAULOTTE® warranty will be performed by the subsidiary which delivered the machine, wherever possible.

G - Other information

1.2.4 - Conditions of warranty

HAULOTTE® guarantees its products against defects, faults or manufacturing defects when the owner or rental company has informed HAULOTTE® of the defect.

The warranty does not cover the consequences of normal wear, nor any defects, failure or damage resulting from poor maintenance or abnormal usage, in particular overloading, impact by an external source, faulty installation or any modification made to products marketed by HAULOTTE® and performed by the owner or rental company.

In the event of operation or use which does not comply with the instructions or recommendations in the maintenance book, warranty claims will not be accepted.

The machine utilisation period must be recorded by reading the engine hour meter whenever an intervention is made. The engine hour meter must be maintained in good working order to guarantee maximum working life and to justify maintenance at the recommended time.

Warranty obligations for the time period stated above will cease immediately in situations where the defect is due to the following reasons :

- Use of spare parts that are not HAULOTTE® originals.
- If elements or products other than those recommended by the manufacturer are used.
- If the HAULOTTE® name, serial numbers or identification marks are removed or altered.
- After an unreasonably long delay before reporting a manufacturing problem.
- If the owner or rental company continues to use the machine despite problems.
- If damage is caused by modifications that do not comply with HAULOTTE® specifications.
- If lubricants, hydraulic oils or fuels that do not comply with HAULOTTE® recommendations are used.
- If the machine is incorrectly repaired or used by the customer.
- In case of an accident caused by a third party.

If no particular agreement has been made, any claims made after the previously established warranty period has expired will be refused.

G - Other information

The present warranty does not cover damage that may result directly or indirectly from any flaws or defects covered by the latter :

- Consumables : No claims will be accepted for objects or parts replaced in the context of normal machine usage.
- Settings : Adjustments of all sorts may become necessary at any time. Therefore adjustments are considered a part of normal machine usage conditions and are not covered by the warranty.
- Hydraulic and fuel circuit contamination : Every possible precaution is taken to ensure that fuel and hydraulic liquid delivered is clean. HAULOTTE® will not accept any claims concerning cleaning of the fuel circuit, filter, injection pump or any other equipment in direct contact with fuel or lubricants.
- Wearing parts (pads, bearings, tires/tyres, connections, etc.) : These parts are, by definition, subject to deterioration during the period of operation. Wearing parts will therefore not be covered by the warranty agreement.

A

B

C

D

E

F

G

H

I

G - Other information

2 - Subsidiary contact information

	<p>HAULOTTE FRANCE PARC DES LUMIERES 601 RUE NICEPHORE NIEPCE 69800 SAINT-PIERRE TECHNICAL Department: +33 (0)820 200 089 SPARE PARTS : +33 (0)820 205 344 FAX : +33 (0)4 72 88 01 43 E-mail : haulottefrance@haulotte.com www.haulotte.fr</p>		<p>HAULOTTE ITALIA VIA LOMBARDIA 15 20098 SAN GIULIANO MILANESE (MI) TEL: +39 02 98 97 01 FAX: +39 02 9897 01 25 E-mail : haulotteitalia@haulotte.com www.haulotte.it</p>		<p>HAULOTTE INDIA Unit No. 1205, 12th floor, Bhumiraj Costarica, Plot No. 1&2, Sector 18, Palm Beach Road, Sanpada, Navi Mumbai- 400 705 Maharashtra, INDIA Tel. : +91 22 66739531 to 35 E-mail : sray@haulotte.com www.haulotte.in</p>
	<p>HAULOTTE HUBARBEITSBÜHNEN GmbH AN DER MÖHLINHALLE 1 D-79189 BAD KROZINGEN-HAUSEN TEL : +49 (0) 7633 806 92-0 FAX : +49 (0) 7633 806 92-18 E-mail : haulotte@de.haulotte.com www.haulotte.de</p>		<p>HAULOTTE VOSTOK 35, SVOBODY STREET Bldg. 19 125362 MOSCOW RUSSIA TEL/FAX : +7 495 221 53 02 / 03 E-mail : info@haulottevostok.ru www.haulotte-international.com</p>		<p>HAULOTTE DO BRASIL AV. Tucunaré, 790 CEP: 06460-020 – TAMBORÉ BARUERI – SAO PAULO – BRASIL TEL : +55 11 4196 4300 FAX : +55 11 4196 4316 E-mail : haulotte@haulotte.com.br www.haulotte.com.br</p>
	<p>HAULOTTE IBERICA C/ARGENTINA Nº 13 - P.I. LA GARENA 28806 ALCALA DE HENARES MADRID TEL : +34 902 886 455 TEL SAT : +34 902 886 444 FAX : +34 911 341 844 E-mail : iberica@haulotte.com www.haulotte.es</p>		<p>HAULOTTE POLSKA Sp. Z.o.o. UL. GRANICZNA 22 05-090 RASZYN - JANKI TEL : +48 22 720 08 80 FAX : +48 22 720 35 06 E-mail : haulottepolska@haulotte.com www.haulotte.pl</p>		<p>HAULOTTE MÉXICO, Sa de Cv Calle 9 Este, Lote 18, Civac, Jiutepec, Morelos CP 62500 Cuernavaca México TEL : +52 77 7321 7923 FAX : +52 77 7516 8234 E-mail : haulotte.mexico@haulotte.com www.haulotte-international.com</p>
	<p>HAULOTTE PORTUGAL ESTRADA NACIONAL NUM. 10 KM. 140 - LETRA K 2695 - 066 BOBADELA LRS TEL : + 351 21 995 98 10 FAX : + 351 21 995 98 19 E-mail : haulotteportugal@haulotte.com www.haulotte.es</p>		<p>HAULOTTE SINGAPORE Pte Ltd. No.26 CHANGI NORTH WAY, SINGAPORE 498812 Parts and service Hotline: +65 6546 6150 FAX : +65 6536 3969 E-mail: haulotteasia@haulotte.com www.haulotte.sg</p>		<p>HAULOTTE MIDDLE EAST FZE PO BOX 293881 Dubai Airport Free Zone DUBAI United Arab Emirates TEL : +971 (0)4 299 77 35 FAX : +971 (0) 4 299 60 28 E-mail : haulottemiddle-east@haulotte.com www.haulotte-international.com</p>
	<p>HAULOTTE SCANDINAVIA AB Taljegårdsgatan 12 431 53 Mölndal SWEDEN TEL : +46 31 744 32 90 FAX : +46 31 744 32 99 E-mail : info@se.haulotte.com spares@se.haulotte.com www.haulotte.se</p>		<p>HAULOTTE TRADING (SHANGHAI) Co. Ltd. #7 WORKSHOP No 191 HUA JIN ROAD MIN HANG DISTRICT SHANGHAI 201108 CHINA TEL : +86 21 6442 6610 FAX : +86 21 6442 6619 E-mail : haulotteshanghai@haulotte.com www.haulotte.cn</p>		<p>HAULOTTE ARGENTINA Ruta Panamericana Km. 34,300 (Ramal A Escobar) 1615 Gran Bourg (Provincia de Buenos Aires) Argentina TEL.: +54 33 27 445991 FAX. +54 33 27 452191 E-mail : haulotteargentina@haulotte.com www.haulotte-international.com</p>
	<p>HAULOTTE UK Ltd STAFFORD PARK 6 TELFORD - SHROPSHIRE TF3 3AT TEL : +44 (0)1952 292753 FAX : + 44 (0)1952 292758 E-mail : salesuk@haulotte.com www.haulotte.co.uk</p>		<p>HAULOTTE GROUP / BILJAX 125 TAYLOR PARKWAY ARCHBOLD, OH 43502 – USA TEL : +1 419 445 8915 FAX :+1 419 445 0367 Toll free : +1 800 537 0540 E-mail : sales@us.haulotte.com www.haulotte-usa.com</p>		<p>HAULOTTE GROUP 1301 E PATRICK STREET FREDERICK, MD 21701 – USA TEL : +1 301 663 0852 FAX :+1 301 663 0572 Toll free : +1 800 537 0540 E-mail : sales@us.haulotte.com www.haulotte-usa.com</p>
	<p>HAULOTTE NETHERLANDS BV Koopvaardijweg 26 4906 CV OOSTERHOUT - Nederland TEL : +31 (0) 162 670 707 FAX : +31 (0) 162 670 710 E-mail info@haulotte.nl</p>		<p>HAULOTTE AUSTRALIA PTY Ltd 46 GREENS ROAD DANDENONG – VIC – 3175 TEL : 1 300 207 683 FAX : +61 (0)3 9792 1011 E-mail : sales@haulotte.com.au</p>		<p>HAULOTTE CHILE El Arroyo 840 Lampa (9380000) Santiago (RM) TEL : + 562 2 3727630 E-mail : haulotte-chile@haulotte.com www.haulotte-chile.com</p>

G - Other information

For electric (battery operated) machines

CALIFORNIA

PROPOSITION 65 BATTERY WARNING

Battery posts, terminals and related accessories contain lead and lead compounds, chemicals known to the State of California to cause cancer and reproductive harm. Batteries also contain other chemicals known to the State of California to cause cancer.

WASH HANDS AFTER HANDLING.

A

B

C

D

E

F

G

H

I

