

# ELECTRIC SCISSOR LIFTS

WARRANTY

HAULOTTE

5 YEARS



**COMPACT 10**  
**COMPACT 12**  
**COMPACT 14**



## SMART RUGGED DESIGN

- > Impact-proof counterweight with integrated ladder protection, AC motors and charger plug
- > Reinforced guardrails with additional vertical stile for maximum durability

## MAXIMIZED POTENTIAL

- > Access all worksites: foldable guardrails, lateral & longitudinal forklift pockets
- > IN/OUT usage\* with full height driving and no load restriction

## UNIQUE USER EXPERIENCE

- > Proportional movements for precise driving (AC motors)
- > Ergonomic upper control box with grab handle & speed selector

## UNBEATABLE SERVICEABILITY

- > Haulotte Activ'Energy Management for battery care
- > On-board & remote settings and diagnostic tools with Haulotte Diag, Haulotte Activ'Screen and Sherpal telematics solution

\* COMPACT 14: indoor only

## ELECTRIC SCISSOR LIFTS

### TECHNICAL DATA

	COMPACT 10 AE	COMPACT 12 AE	COMPACT 14 AE
Working height	10 m	11.75 m	13.75 m
Platform height	8 m	9.75 m	11.75 m
Max. drive working height	8 m	9.75 m	11.75 m
Lift capacity - inside	450 kg (3 pers.)	320 kg (3 pers.)	
Lift capacity - outside	450 kg (1 pers.)	320 kg (1 pers.)	NA
Lift capacity on the extension		120 kg	
<b>A</b> Platform length		2.4 m	
<b>B</b> Platform length - extended		3.32 m	
Length - extension		0.92 m	
<b>C</b> Platform width - outside		1.17 m	
<b>D</b> Height - stowed	2.35 m	2.47 m	2.72 m
Height - guardrails lowered	1.65 m	1.77 m	2.02 m
<b>E</b> Overall width		1.20 m	
<b>F</b> Length		2.5 m	
<b>G</b> Wheelbase		1.86 m	
<b>H</b> Ground clearance - center		12.5 cm	
Ground clearance - deployed potholes		2 cm	
Drive speed		0.7 / 1.5 / 4.2 km/h	
Gradeability		25 %	
Tilt (longitudinal / lateral)		3.5° / 1.5°	
Turning radius - outside		1.83 m	
Non-marking tyres		15 x 5	
Batteries		24 V - 225 Ah [C20]	
Hydraulic system capacity	10 l	14 l	
Weight	2 490 kg	2 940 kg	3 070 kg

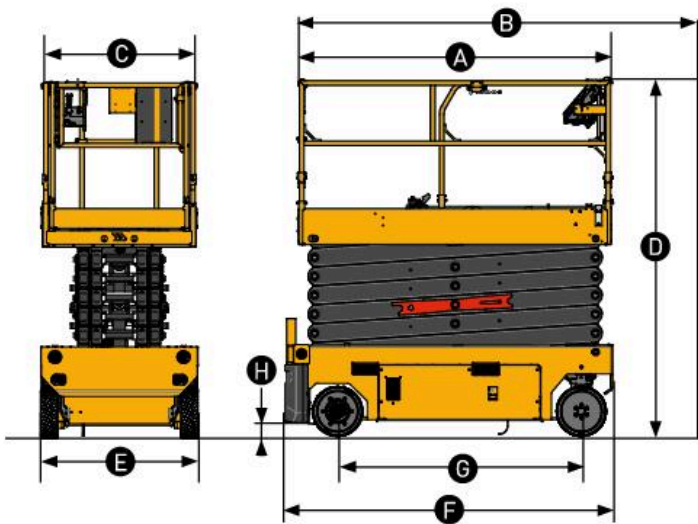

### STANDARD EQUIPMENT

- > Haulotte Activ'Energy Management: Smart CAN charger
- > 27A multivoltage charger
- > Battery access with swing out tray
- > Battery level indicator
- > Haulotte Activ'Screen (battery charge information, hourmeter, service alerts & failures in code or in text...)
- > Lateral & longitudinal forklift pockets
- > Foldable guardrails
- > Front platform extension
- > AC motors
- > Mobile upper control box
- > 2 drive speeds selector
- > Manual emergency descent
- > Mobile pothole guards
- > MyHaulotte multi-services portal access
- > 2 front steering wheels, 2 rear drive wheels
- > Solid non marking tires
- > Motion alarm
- > Electric brake release system
- > Drop bar entry

### OPTIONS AND ACCESSORIES

- > Haulotte Activ'Energy Management: automatic or manual battery water filling systems
- > AGM maintenance-free batteries
- > Secondary guarding system
- > Telematics solutions
- > Pipe cradle
- > Panel carrier
- > Swing gate entry
- > Additional protection of upper & lower control box
- > Basket plug (110 / 230 V)
- > Working light
- > Flashing light (single, dual or 360°)
- > Biodegradable hydraulic oil
- > Cold weather hydraulic oil

