

LIGHT-WEIGHT SELF-PROPELLED BOOMS



**HLA 16 PX**

**HLA 19 PX**

### Access like never before

- Hydraulic outriggers and automatic leveling allow operation in under 30 seconds
- High performance 4WD and light weight provide access to places larger and heavier machines cannot go
- Easily transported on a trailer with no commercial driver's license requirement
- Dual power source (DC / Gas) allows for indoor/outdoor use

### Optimum performance

- 4,000 Watt generator
- Air / water lines to platform
- 110V GFI protected power to the platform



**Haulotte**   
GROUP

More than lifting

[www.haulotte.com](http://www.haulotte.com)



# HLA 16 PX - HLA 19 PX

LIGHT-WEIGHT SELF-PROPELLED

## TECHNICAL DATA

	HLA 16 PX	HLA 19 PX
Working height	15.54 m	18.67 m
Platform height	13.72 m	16.84 m
Horizontal outreach (from centerline)	8.23 m	10.19 m
Horizontal outreach (from edge of	6.4 m	8.33 m
Up and over height	6.33 m	7.04 m
Lift capacity	227 kg	
A - Length - stowed	5.54 m	6.45 m
B - Width stowed	1.67 m	1.72 m
C - Height stowed	2.01 m	2.06 m
D - Wheelbase	2.67 m	3.08 m
E - Ground clearance	15 cm	25 cm
F x G - Platform size	1.52 x 0.76	
H x I - Outrigger footprint	3.76 x 3.45	4.24 x 3.89
Turntable rotation	350° non-continuous	
Jib - length	1.3 m	
Jib - Vertical motion	150° (+70 / -80)	
Drive speed	7.6 km/h	7.6 km/h
Gradeability	45%	
Leveling capability	12.5°	
Turning radius - inside (2WS)	1.62 m	3.45 m
Turning radius - inside (4WS)	3.05 m	2.03 m
Tire size	26 x 12 Bar lug	
Batteries	4 x 6V 245 Amp-hr	
Engine	31 hp gas Kubota	31 hp gas Kubota
Weight	2358 kg	2721 kg

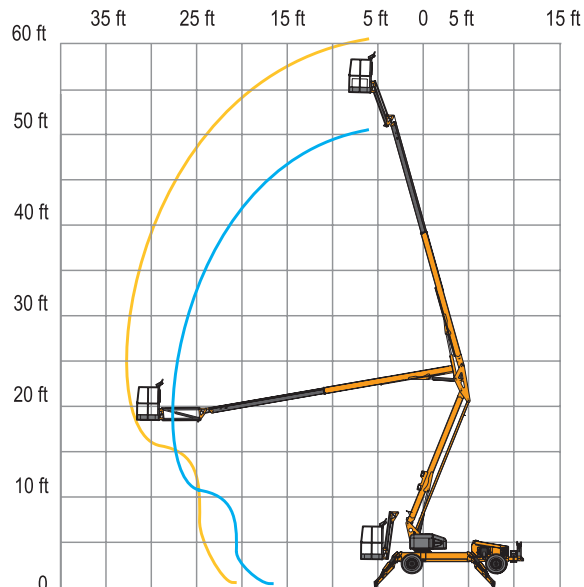
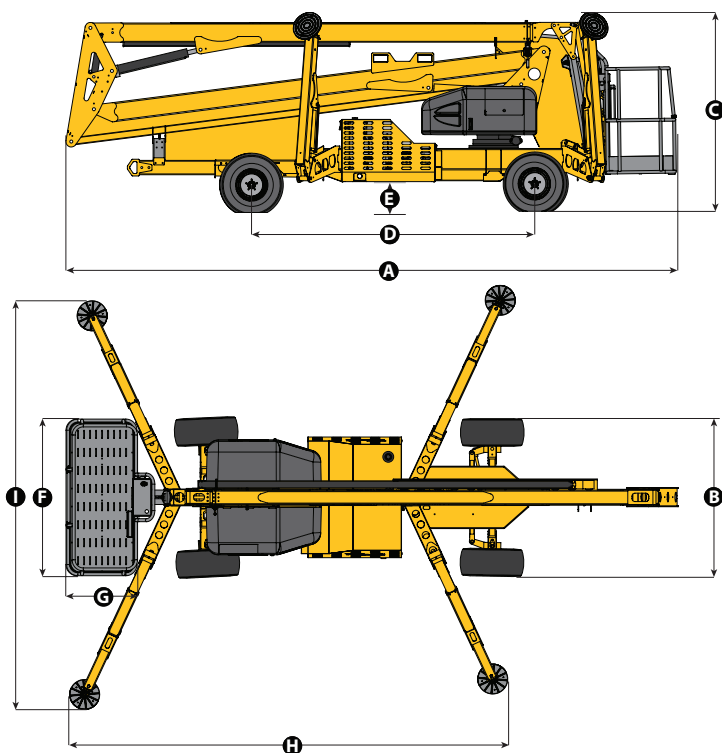

## STANDARD EQUIPMENT

- Hydraulic outriggers
- Automatic leveling system (leveling capability 12.5°)
- Self-leveling platform
- Air and water lines to platform
- 110V GFI protected outlet to platform and base
- 4,000 W generator
- Hour meter
- Battery condition indicator
- Dual power system
- Easy to use controls with logically positioned buttons
- Tilt alarm / sensor
- Spring applied hydraulic released brakes
- Inboard 25 amp charger
- Bar lug tires
- 4 wheel steering (standard on HLA19PX)

## OPTIONS AND ACCESSORIES

- Material lifting hook
- Platform rotator (manual)
- Flashing beacon
- Fluorescent tube caddy
- Tool tray
- Turf tires
- Dual fuel - 32.5 Hp gas / liquid propane Kubota