



Operation and Safety Manual

13MSPT



ANSI

31210001
October 24, 2007

FOREWORD

This manual is a very important tool! Keep it with the machine at all times.

The purpose of this manual is to provide owners, users, operators, lessors, and lessees with the precautions and operating procedures essential for the safe and proper machine operation for its intended purpose.

Due to continuous product improvements, JLG Industries, Inc. reserves the right to make specification changes without prior notification. Contact JLG Industries, Inc. for updated information.

Other Publications Available:

Service and maintenance manual	31210003
Illustrated parts.....	31210004
Hydraulic schematic.....	FL0148
Electrical schematic	ELE247

SAFETY ALERT SYMBOLS AND SAFETY SIGNAL WORDS



This is the Safety Alert Symbol. It is used to alert you to the potential personal injury hazards. Obey all safety messages that follow this symbol to avoid possible injury or death.

DANGER

INDICATES AN IMMINENTLY HAZARDOUS SITUATION. IF NOT AVOIDED, WILL RESULT IN SERIOUS INJURY OR DEATH. THIS DECAL WILL HAVE A RED BACKGROUND.

WARNING

INDICATES A POTENTIALITY HAZARDOUS SITUATION. IF NOT AVOIDED, COULD RESULT IN SERIOUS INJURY OR DEATH. THIS DECAL WILL HAVE AN ORANGE BACKGROUND.

CAUTION

INDICATES A POTENTIALITY HAZARDOUS SITUATION. IF NOT AVOIDED, MAY RESULT IN MINOR OR MODERATE INJURY. IT MAY ALSO ALERT AGAINST UNSAFE PRACTICES.

INDICATES PROCEDURES ESSENTIAL FOR SAFE OPERATION. THIS DECAL WILL HAVE A YELLOW BACKGROUND.

WARNING

THIS PRODUCT MUST COMPLY WITH ALL SAFETY RELATED BULLETINS, CONTACT JLG INDUSTRIES, INC. OR THE LOCAL AUTHORIZED JLG REPRESENTATIVE FOR INFORMATION REGARDING SAFETY-RELATED BULLETINS WHICH MAY HAVE BEEN ISSUED FOR THIS PRODUCT.

IMPORTANT

JLG INDUSTRIES, INC. SENDS SAFETY RELATED BULLETINS TO THE OWNER OF RECORDS OF THIS MACHINE. CONTACT JLG INDUSTRIES, INC. TO ENSURE THAT THE CURRENT OWNER RECORDS ARE UPDATED AND ACCURATE.

IMPORTANT

JLG INDUSTRIES, INC. MUST BE NOTIFIED IMMEDIATELY IN ALL INSTANCES WHERE JLG PRODUCTS HAVE BEEN INVOLVED IN AN ACCIDENT INVOLVING BODILY INJURY OR DEATH OF PERSONNEL OR WHEN SUBSTANTIAL DAMAGE HAS OCCURRED TO PERSONAL PROPERTY OR THE JLG PRODUCT.

For:

- Accident Reporting
- Product Safety Publications
- Current Owner Updates
- Questions Regarding Product Safety
- Standards and Regulations Compliance Information
- Questions Regarding Special Product Applications
- Questions Regarding Product Modifications

CONTACT:

In USA:

JLG Industries, Inc.
Product Safety & Reliability Department,
1 JLG Drive
McConnellsburg, PA
USA 17233-9533
Toll Free: (877) 554-7233
Tel.: (717) 485-5161
Fax: (717) 485-6573
Email : ProductSafety@JLG.com

Outside USA:

JLG Industries,
Wright Business Centre,
1 Lonmay Road
Queenslie,
Glasgow
Scotland G33 4EL
Tel : +44(0)141 781 6700
Fax : +44(0)141 773 1907
Email : ProductSafety@JLG.com

or Your Local JLG Office
(See addresses on inside of manual cover)

REVISION LOG

Original Issue	- January 16, 2006
Revision Standard A.96-2006 update	- May 11, 2007 - ANSI
Revision MAD and Rear cover	- October 24, 2007 -

SECTION - 1 - SAFETY PRECAUTIONS

1.1 GENERAL 1-1
 1.2 PRE-OPERATION 1-1
 Operator Training and Knowledge 1-1
 Workplace Inspection 1-1
 Machine Inspection 1-1
 1.3 OPERATION 1-1
 General 1-1
 Trip and Fall Hazards 1-2
 Electrocution Hazards 1-2
 Tipping Hazards 1-3
 Crushing and Collision Hazards 1-3
 1.4 TOWING, LIFTING, AND HAULING 1-4
 1.5 ADDITIONAL HAZARDS / SAFETY 1-4

SECTION - 2 - USER RESPONSIBILITIES, MACHINE PREPARATION, AND INSPECTION

2.1 PERSONNEL TRAINING 2-1
 Operator Training 2-1
 Training Supervision 2-1
 Operator Responsibility 2-1
 2.2 PREPARATION, INSPECTION, AND MAINTENANCE 2-1
 2.2 PRE-START INSPECTION 2-3
 2-3-1 Walk-around inspection 2-4
 2-3-2 Function Check 2-5
 Control Consoles 2-5
 Tilt Sensor Check 2-5
 Mast Sensor Check 2-6
 Gate Sensors Check 2-6

SECTION - 3 - MACHINE CONTROLS AND INDICATORS

3.1 GENERAL 3-1
 3.2 CONTROLS AND INDICATORS 3-1
 Ground Control Station 3-2
 Manual Lowering Control 3-2
 Platform Control Station 3-3
 Platform Control Indicator Panel 3-4
 Auxiliary Control Station 3-4

SECTION - 4 - MACHINE OPERATION

4.1 EMERGENCY CONTROL OPERATION 4-1
 Platform/Ground Select Switch 4-1
 Emergency Stop Switch 4-1
 Brake Locking / Unlocking Selector 4-1
 4.2 PLATFORM CONTROLS 4-1
 Traveling (Driving) 4-1
 Raising And Lowering Mast 4-2
 Raising And Lowering Shelf 4-2
 Work Platform Functions Combination 4-2
 4.3 MANUAL LOWERING CONTROLS 4-3
 4.4 ALARMS 4-3
 Horn 4-3
 Motion Alarms 4-3
 Tilt Light And Alarm 4-3
 4.5 SHUT DOWN AND PARK 4-3
 4.6 CHARGER 4-3
 Charger voltage 4-3
 TECSUP HF Electronic Charger 4-4

4.7 EMERGENCY TOWING 4-4
 4.8 LIFTING AND TIE DOWN 4-5
 Lifting 4-5
 Tie Down 4-5
 4.9 LOADING AND UNLOADING 4-6
 Using a fork lift truck 4-6
 Using a winch for loading 4-6

SECTION - 5 - DECALS

SECTION - 6 - EMERGENCY PROCEDURES

6.1 GENERAL 6-1
 6.2 INCIDENT NOTIFICATION 6-1
 6.3 EMERGENCY OPERATION 6-1
 Operator Unable to Control Machine 6-1
 Platform or Mast Caught Overhead 6-1
 6.4 EMERGENCY LOWERING 6-1
 6.5 EMERGENCY TOWING PROCEDURES 6-1

SECTION - 7 - INSPECTION AND REPAIR LOG

SECTION - 8 - GENERAL SPECIFICATIONS & OPERATOR MAINTENANCE

8.1 INTRODUCTION 8-1
 8.2 OPERATING SPECIFICATIONS 8-1
 Fluid Capacities 8-1
 Electric Power Units 8-1
 Batteries 8-1
 8.3 OPERATOR MAINTENANCE 8-2
 Batteries 8-2
 Lifting Chains Lubrication 8-4
 Mast Sections Lubrication 8-4
 Shelf Section Lubrication 8-4
 Wheel Bearing Lubrication 8-5
 Wheel Reducer Lubrication 8-5
 Hydraulic Oil Reservoir 8-5
 Shelf Hydraulic Unit Reservoir 8-6
 Tires And Wheels 8-7
 Verification of the Tilt Alarm Setting 8-8
 Wear Check of the Steering Brackets Thrust Washers 8-9
 Wear Check of the Shelf Sliding Blocks 8-9
 Wear Check of the Wheel Motor Brakes 8-9
 Verification of the Lifting Chains 8-10

SECTION 1. SAFETY PRECAUTIONS

1.1 GENERAL

This section outlines the necessary precautions for proper and safe machine operation and maintenance. For proper machine use, it is mandatory that a daily routine is established based on the content of this manual. A maintenance program, using the information provided in this manual and the Service Manual, must also be established by a qualified person and followed to ensure the machine is safe to operate.

If there are any questions with regard to safety, training, inspection, maintenance, application, and operation, please contact JLG Industries, Inc. ("JLG").

⚠ WARNING

FAILURE TO COMPLY WITH THE SAFETY PRECAUTIONS LISTED IN THIS MANUAL COULD RESULT IN MACHINE DAMAGE, PROPERTY DAMAGE, PERSONAL INJURY OR DEATH.

1.2 PRE-OPERATION

Operator Training and Knowledge

- Read and understand this manual before operating the machine.

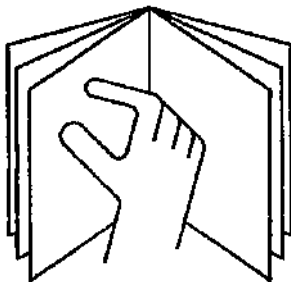

- Do not operate this machine until complete training is performed by authorized persons.
- Only authorized and qualified personnel can operate the machine.
- Read, understand, and obey all DANGERS, WARNINGS, CAUTIONS, and operating instructions on the machine and in this manual.
- Use the machine in a manner which is within the scope of its intended application set by JLG.
- All operating personnel must be familiar with the emergency controls and emergency operation of the machine as specified in this manual.
- Read, understand, and obey all applicable employer, local, and governmental regulations as they pertain to operation of the machine.

Workplace Inspection

- The operator is to take safety measures to avoid all hazards in the work area prior to machine operation.

- Do not operate or raise the platform while on trucks, trailers, railway cars, floating vessels, scaffolds or other equipment unless approved in writing by JLG.
- Do not operate the machine in hazardous environments unless approved for that purpose by JLG.
- Be sure that the ground conditions are able to support the maximum load of the machine.
- This machine can be operated in temperatures of 0° F to 104° F (-20° C to 40° C). Consult JLG for operation outside this range.

Machine Inspection

- Before machine operation, perform inspections and functional checks. Refer to Section 2 of this manual for detailed instructions.
- Do not operate this machine until it has been serviced and maintained according to requirements specified in the Service Manual.
- Be sure the trigger on the function enable switch and all other safety devices are operating properly. Modification of these devices is a safety violation.

⚠ DANGER

MODIFICATION OR ALTERATION OF AN AERIAL WORK PLATFORM SHALL BE MADE ONLY WITH WRITTEN PERMISSION FROM THE MANUFACTURER

- Do not operate any machine on which safety or instruction placards or decals are missing or illegible.
- Avoid any buildup of debris on the platform floor. Keep mud, oil, grease, and other slippery substances from footwear and platform floor.
- Do not clean electrical components with a high pressure cleaner.

1.3 OPERATION

General

- Do not use the machine for any purpose other than positioning personnel, their tools, and equipment.
- Never operate a machine that is not working properly. If a malfunction occurs, shut down the machine.
- Never slam a control switch or lever through neutral to an opposite direction. Always return switch to neutral and stop before moving the switch to the next function. Operate controls with slow and even pressure.
- Park the machine in stowed position when not in service.

SECTION 1 - SAFETY PRECAUTIONS

- Do not allow personnel to tamper with or operate the machine from the ground with personnel in the platform, except in an emergency.
- Do not carry materials directly on platform railing unless approved by JLG.
- Always ensure that power tools are properly stowed and never left hanging by their cord from the platform work area.
- Supplies or tools which extend outside the platform are prohibited unless approved by JLG.
- Do not assist a stuck or disabled machine by pushing, pulling, or by using extending structure functions. Only pull the unit from the towing points on the chassis.
- Do not place extending structure or platform against any structure to steady the platform or to support the structure.
- Stow extending structure and shut off all power before leaving machine.

Trip and Fall Hazards

- JLG recommends that occupants of the platform wear a full body harness with a lanyard attached to an authorized lanyard anchorage point (Max. lanyard length : 30" (76 cm)). For further information regarding fall arrest protection requirements on JLG products, contact JLG Industries, Inc.



- Before operating the machine, make sure all gates are closed and fastened in their proper position.

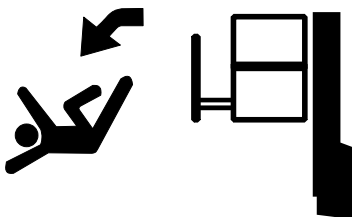

- Keep both feet firmly positioned on the platform floor at all times. Never use ladders, boxes, steps, planks, or similar items on platform to provide additional reach.
- Always enter or leave the platform using the access gate.
- Use extreme caution when entering or leaving platform. Be sure that the mast assembly is fully lowered. Face the machine, maintain "three point contact" with the machine, using two hands and one foot or two feet and one hand during entry and exit.
- When driving, always ensure all equipment, parcels and materials on the shelf are tied down. Use the

removable tube to restrain parcels and bulky materials positioned on the shelf.

- Do not sit or climb on the shelf.

Electrocution Hazards

- This machine is not insulated and does not provide protection from contact or proximity to electrical current.

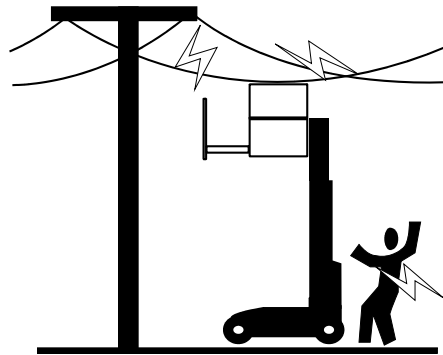
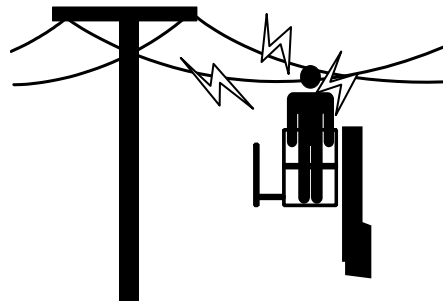

- Maintain distance from electrical lines, apparatus, or any energized (exposed or insulated) parts according to the Minimum Approach Distance (MAD) as shown in Table 1-1.
- Allow for machine movement and electrical line swaying.

Table 1-1. Minimum Approach Distance (M.A.D.)

Voltage Range (Phase to Phase)	MINIMUM APPROACH DISTANCE in feet (meters)
0 to 50 V	10 (3)
Over 50 V to 200 kV	15 (5)
Over 200 kV to 350 kV	20 (6)
Over 350 kV to 500 kV	25 (8)
Over 500 kV to 750 kV	35 (11)
Over 750 kV to 1000 kV	45 (14)

NOTE: This requirement shall apply except where employer, local or governmental regulations are more stringent.

⚠ DANGER

DO NOT MANEUVER MACHINE OR PERSONNEL INSIDE PROHIBITED ZONE (MAD). ASSUME ALL ELECTRICAL PARTS AND WIRING ARE ENERGIZED UNLESS KNOWN OTHERWISE.

- Maintain a clearance of at least 10 ft (3m) between any part of the machine and its occupants, their tools and their equipment from any electrical line or apparatus carrying up to 50 000 volts. One foot (0,3m) additional clearance is required for every additional 30 000 volts or less.
- The minimum approach distance may be reduced if insulating barriers are installed to prevent contact and the barriers are rated for the voltage of the line being guarded. These barriers shall not be part of (or attached to) the machine. The minimum approach distance shall be reduced to a distance within the designed working dimensions or the insulating barrier. This determination shall be made by a qualified person in accordance with employer, local or governmental requirements for work practices near energized equipment.

Tipping Hazards

- The user should be familiar with the surface before driving. Do not exceed the allowable sideslope and grade while driving.

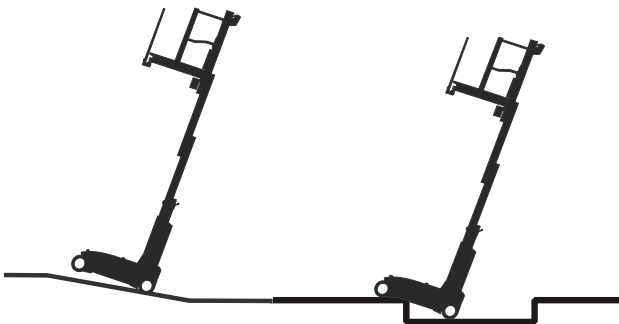

- Never exceed the maximum platform capacity. Distribute loads evenly on platform floor.
- Never exceed the maximum shelf capacity. Distribute loads evenly on shelf floor.
- Before driving on floors, bridges, trucks, and other surfaces, check allowable capacity of the surfaces. Check the ramp or slope for good adhesion of the wheels. Ensure that the driving surfaces are free of moisture, ice, grease or from any other substance that could affect traction.
- Do not elevate platform or drive with platform elevated while on a sloping, uneven, or soft surface.
- Do not raise the platform or drive from an elevated position unless the machine is on firm, level surfaces and evenly supported.
- To prevent accident while travelling on slopes (20% max), the platform **MUST** be fully lowered. It is recommended to drive up the slope in **FORWARD** gear

and to **REVERSE** down the slope as the machine will perform better.

- Keep the chassis of the machine at least 2 ft (0,6m) from holes, bumps, drop-offs, obstructions, debris, concealed holes, and other potential hazards on the floor/surface.
- Do not push or pull any object with the extending structure.
- Never attempt to use the machine as a crane. Do not tie-off machine to any adjacent structure.
- Do not operate the machine with wind.
- Do not increase the surface area of the platform or the load. Increase of the area exposed to the wind will decrease stability.
- Do not increase the platform or the shelf size with unauthorized deck extensions or attachments.
- If extending structure assembly or platform is in a position that one or more wheels are off the ground, all persons must be removed before attempting to stabilize the machine. Use appropriate equipment to stabilize machine and remove personnel.

Crushing and Collision Hazards

- Approved head gear must be worn by all operating and ground personnel.
- Check work area for clearances overhead, on sides, and bottom of platform when lifting or lowering platform, and driving.

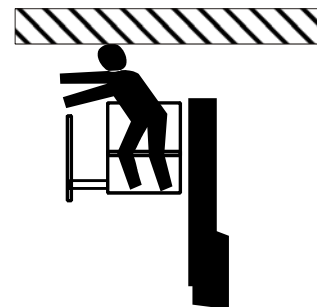

- During operation, keep all body parts inside platform railing.
- Always post a lookout when driving in areas where vision is obstructed.
- Keep non-operating personnel at least 6 ft (1,8m) away from machine during all driving operations.
- Limit travel speed according to conditions of ground surface, congestion, visibility, slope, location of personnel, and other factors which may cause collision or injury to personnel.
- Be aware of stopping distances in all drive speeds. When driving in high speed, reduce to low speed before stopping.
- Do not use high speed drive in restricted or close quarters or when driving in reverse.

SECTION 1 - SAFETY PRECAUTIONS

- Exercise extreme caution at all times to prevent obstacles from striking or interfering with operating controls, persons in the platform or with operating parcels on the shelf.
- Be sure that operators of other overhead and floor level machines are aware of the aerial work platform's presence. Disconnect power to overhead cranes.
- Warn personnel not to work, stand, or walk under a raised extending structure or platform. Position barricades on floor if necessary.

1.4 TOWING, LIFTING, AND HAULING

- Never allow personnel in platform while towing, lifting, or hauling.
- This machine should not be towed, except in the event of emergency, malfunction, power failure, or loading/unloading. Refer to the Emergency Procedures section of this manual for emergency towing procedures.
- Ensure extending structure is in the stowed position prior to towing, lifting or hauling. The platform must be completely empty of tools. The shelf must be completely empty. The removable tube must be stored under the platform.
- When lifting machine, lift only at designated areas of the machine. Lift the unit with equipment of adequate capacity.
- Refer to the Machine Operation section of this manual for lifting information.

1.5 ADDITIONAL HAZARDS / SAFETY

- Do not use machine as a ground for welding.
- When performing welding or metal cutting operations, precautions must be taken to protect the chassis from direct exposure to weld and metal cutting spatter.
- Battery fluid is highly corrosive. Avoid contact with skin and clothing at all times.
- Charge batteries only in a well ventilated area.

SECTION 2. USER RESPONSIBILITIES, MACHINE PREPARATION, AND INSPECTION

2.1 PERSONNEL TRAINING

The aerial platform is a personnel handling device; so it is necessary that it be operated and maintained only by trained personnel.

Persons under the influence of drugs or alcohol or who are subject to seizures, dizziness or loss of physical control must not operate this machine.

Operator Training

Operator training must cover:

1. Use and limitations of the controls in the platform and at the ground, emergency controls and safety systems.
2. Control labels, instructions, and warnings on the machine.
3. Rules of the employer and government regulations.
4. Use of approved fall protection device.
5. Enough knowledge of the mechanical operation of the machine to recognize a malfunction or potential malfunction.
6. The safest means to operate the machine where overhead obstructions, other moving equipment, and obstacles, depressions, holes, drop-offs.
7. Means to avoid the hazards of unprotected electrical conductors.
8. Specific job requirements or machine application.

Training Supervision

Training must be done under the supervision of a qualified person in an open area free of obstructions until the trainee has developed the ability to safely control and operate the machine.

Operator Responsibility

The operator must be instructed that he/she has the responsibility and authority to shut down the machine in case of a malfunction or other unsafe condition of either the machine or the job site.

2.2 PREPARATION, INSPECTION, AND MAINTENANCE

The following table covers the periodic machine inspections and maintenance required by JLG Industries, Inc. Consult local regulations for further requirements for aerial work platforms. The frequency of inspections and maintenance must be increased as necessary when the machine is used in a harsh or hostile environment, if the machine is used with increased frequency, or if the machine is used in a severe manner.

SECTION 2 - USER RESPONSIBILITIES, MACHINE PREPARATION, AND INSPECTION

Table 2-1. Inspection and Maintenance Table

Type	Frequency	Primary Responsibility	Service Qualification	Reference
Pre-Start Inspection	Before using each day; or whenever there's an Operator change.	User or Operator	User or Operator	Operator and Safety Manual
Pre-Delivery Inspection (See Note)	Before each sale, lease, or rental delivery.	Owner, Dealer, or User	Qualified JLG Mechanic	Service and Maintenance Manual and applicable JLG inspection form
Frequent Inspection (See Note)	In service for 3 months or 150 hours, whichever comes first; or Out of service for a period of more than 3 months; or Purchased used.	Owner, Dealer, or User	Qualified JLG Mechanic	Service and Maintenance Manual and applicable JLG inspection form
Annual Machine Inspection (See Note)	Annually, no later than 13 months from the date of prior inspection.	Owner, Dealer, or User	Qualified JLG Mechanic	Service and Maintenance Manual and applicable JLG inspection form
Preventative Maintenance	At intervals as specified in the Service and Maintenance Manual.	Owner, Dealer, or User	Qualified JLG Mechanic	Service and Maintenance Manual

NOTE: Inspection forms are available from JLG. Use the Service and Maintenance Manual to perform inspections.

2.3 PRE-START INSPECTION

The Pre-Start Inspection should include each of the following:

1. **Cleanliness** – Check all surfaces for leakage (oil, or battery fluid) or foreign objects. Report any leakage to the proper maintenance personnel.
2. **Structure** – Inspect the machine structure for dents, damage, weld or parent metal cracks or other discrepancies.

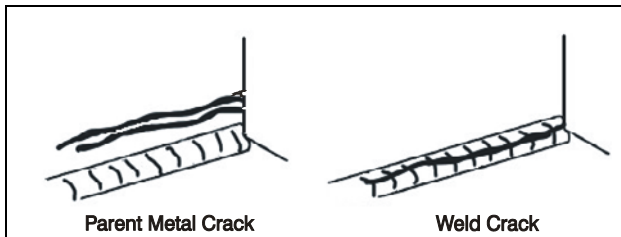

3. **Decals and Placards** – Check all for cleanliness and legibility. Make sure none of the decals and placards are missing. Make sure all illegible decals and placards are cleaned or replaced.
4. **Operation and Safety Manuals** – Make sure a copy of the Operator and Safety Manual, AEM Safety Manual (ANSI markets only), and ANSI Manual of Responsibilities (ANSI markets only) is enclosed in the weather resistant storage container.
5. **“Walk-Around” Inspection** – Refer to Figure 2-1.
6. **Battery** – Charge as required.
7. **Hydraulic Oil** – Check the hydraulic oil levels. Ensure hydraulic oil is added as required.
8. **Accessories/Attachments** - Reference the Operator and Safety Manual of each attachment or accessory installed upon the machine for specific inspection, operation, and maintenance instructions.
9. **Function Check** – Once the “Walk-Around” Inspection is complete, perform a function check (section 2-3-2) of all systems in an area free of overhead and ground level obstructions. Refer to Section 4 for more specific operating instructions.

⚠ WARNING

IF THE MACHINE DOES NOT OPERATE PROPERLY, TURN OFF THE MACHINE IMMEDIATELY! REPORT THE PROBLEM TO THE PROPER MAINTENANCE PERSONNEL. DO NOT OPERATE THE MACHINE UNTIL IT IS DECLARED SAFE FOR OPERATION.

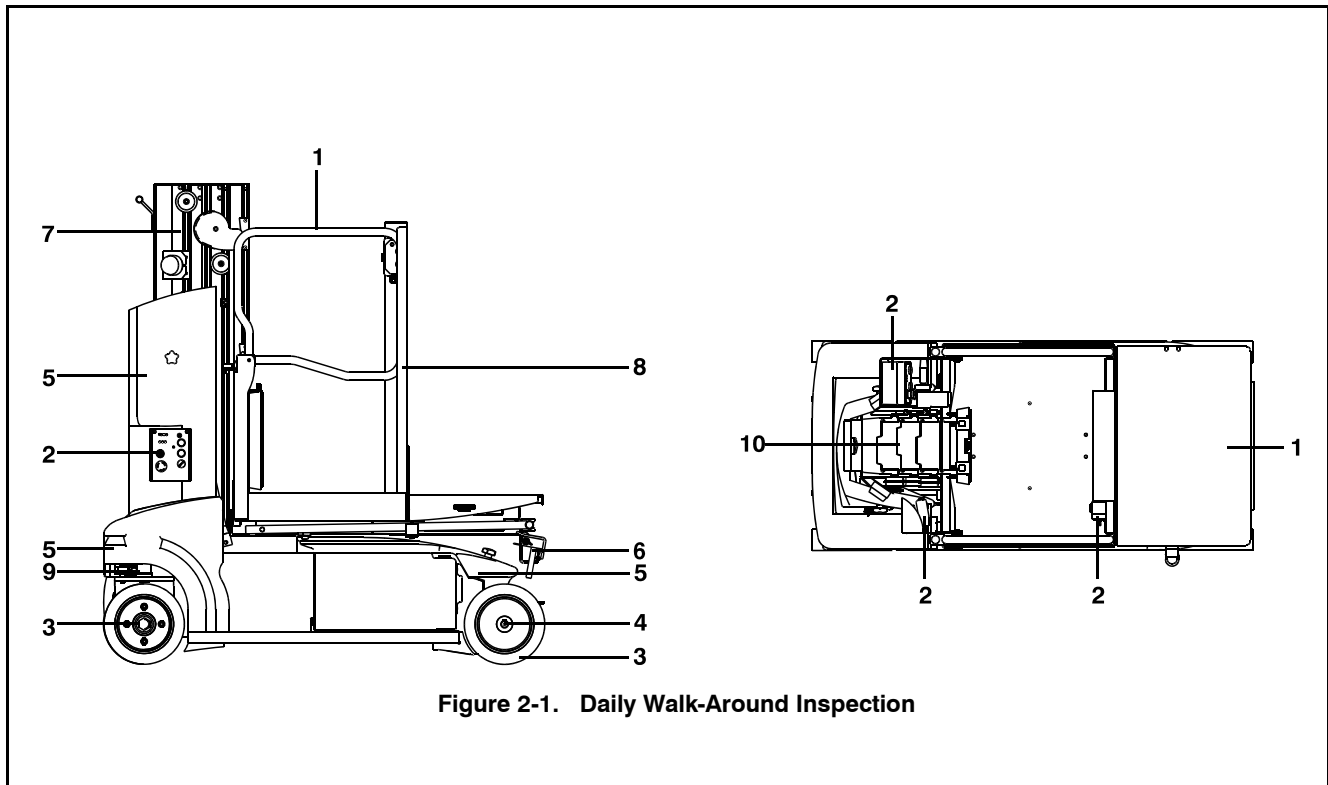

Figure 2-1. Daily Walk-Around Inspection

2.3.1 Walk-Around Inspection

Begin the "Walk-Around Inspection" at Item 1, as noted on the diagram. Continue checking each item in sequence for the conditions listed in the following checklist.

⚠ WARNING

TO AVOID POSSIBLE INJURY, BE SURE MACHINE POWER IS OFF. DO NOT OPERATE MACHINE UNTIL ALL MALFUNCTIONS HAVE BEEN CORRECTED.

INSPECTION NOTE: *On all components, make sure there are no loose or missing parts, that they are securely fastened, and no visible damage, leaks or excessive wear exists in addition to any other criteria mentioned.*

1. **Shelf, Platform Guardrails and Gates** - No visible damage. The gates open and close properly.
2. **Platform & Ground Control Consoles** - Switches and levers return to neutral, decals/placards secure and legible, control markings legible. Trigger works properly, not modified, disabled or blocked.
3. **Wheel/Tire Assemblies** - Properly secured, no missing lug nuts, screws and washers.
4. **Drive Motor, Brake** - No visible damage.
5. **Hood Assemblies** - See Inspection Note.
6. **Removable Tube Assembly** - Must be installed and in good condition.
7. **Mast Assembly** - No visible damage; all pins and hydraulic hoses undamaged, no leaks.
8. **Shelf Assembly** - No visible damage; all pins and hydraulic hoses undamaged, no leaks. Good condition of the lifting cables.
9. **Steering Assembly** - No visible damage. Steering spindles : see inspection note.
10. **Lifting Chains, Chain Yokes and Clevis Pins** - Must be installed and in good condition. Chains must be correctly tensioned and lubricated.

2.3.2 Function Check

Refer to section 3 & 4 for description and operation.

⚠ WARNING

DO NOT OPERATE MACHINE UNTIL ALL MALFUNCTIONS HAVE BEEN CORRECTED.

Perform the Function Check as follows with the machine on a firm level surface in an area free from obstructions :

Control Consoles

1. From the Ground Control Console :
 - Operate all functions;
 - Ensure that all machine functions are disabled when the Emergency Stop Button is pushed in;
 - Raise the mast by approximately 3.3 ft (1m). Simultaneously operate a mast lowering and raising movement :
 - Only the mast lowering movement shall occur.
 - Position the brake release selector to "Brakes unlocked". Try to use the Ground Control Console and ensure that no movement occurs.
 - Position the selector switch to Platform Control Console. Try to use the Ground Control Console and ensure that no movement occurs.
 - Position the Brake Release Selector to "Wheel Motor Brakes Locked".

2. From the Platform Control Consoles (Platform and Auxiliary Consoles) :
 - Ensure that the platform control consoles are firmly secured;
 - Ensure proper operation of horn;
 - Ensure proper operation of all functions;
 - Ensure that all machine functions are disabled when the Emergency Stop Button is pushed in;
 - Ensure that no functions can be operated unless the trigger on the function enable switch is pressed, except the shelf functions.
 - Simultaneously operate a drive movement and mast movement. Only the mast movement shall occur;
 - Drive the machine on a grade, not to exceed the rated gradeability and stop to ensure the brakes hold;

⚠ DANGER

IF THE MACHINE IS NOT MAINTAINED IN POSITION, CHANGE THE BRAKES.

Tilt Sensor Check

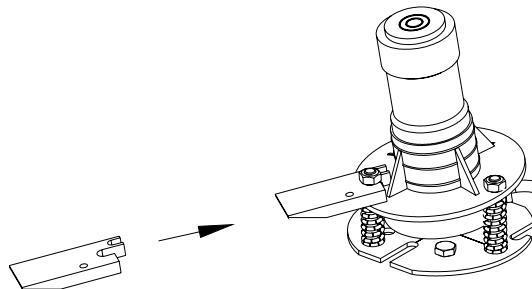

Check the tilt sensor, located at the center of the machine under chassis cover, to ensure proper operation. Wedge a block (P/N : ST2741 located in the manual storage container) as illustrated above to activate the tilt sensor and keep it tilted. Raise the mast by approximately 1.6 ft (0.5 m). The system is functioning properly if :

1. From the Platform Control Console :
 - An acoustic alarm sounds.
 - The corresponding red warning indicator (tilt) lights up on the Platform Control Panel.
 - The drive function is disabled.
 - The mast raising function is disabled.
 - All other functions are working normally.

2. From the Ground Control Console :
 - All functions work normally.

IMPORTANT

THIS FEATURE IS OPERATIONAL WHEN THE MACHINE IS CONTROLLED FROM THE PLATFORM CONTROL CONSOLE AND WHEN THE PLATOFRM HAS LEFT ITS STOWED POSITION.

NOTE: See section 8 for verification of the system settings.

Mast Sensor Check

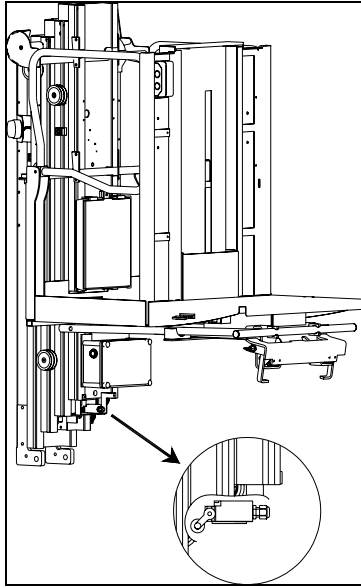

Check the mast sensor located under the last mast section to ensure proper operation. Raise the mast by approximately 1.6 ft (0.5 m). The system is functioning properly if :

1. From the Platform Control Consoles :
 - Every drive movement of the machine is performed at slow speed.
2. From the Ground Control Console :
 - All functions work normally.

Gate Sensors Check

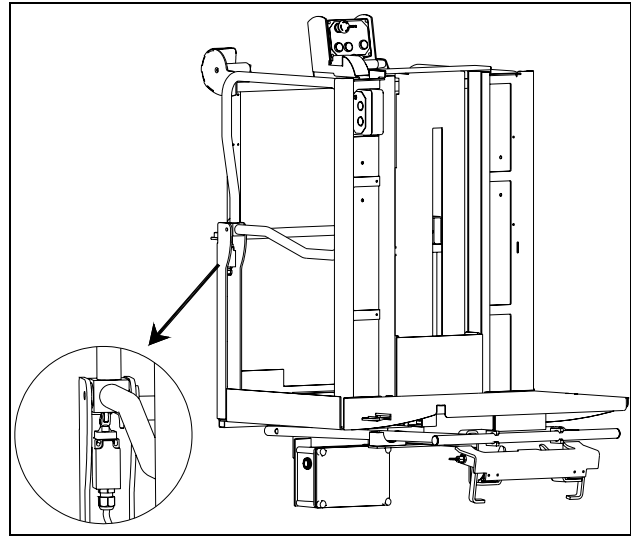

Check the gate sensors to ensure proper operation. Open the right platform gate. The system is functioning properly if :

1. From the Platform Control Console :
 - The driving function is disabled.
 - The steering function is disabled.
 - The mast function is disabled.
 - The shelf function works normally.
2. From the Ground Control Console :
 - All functions work normally.
3. Repeat steps 1 to 2 for the left platform gate sensor.

SECTION 3. MACHINE CONTROLS AND INDICATORS

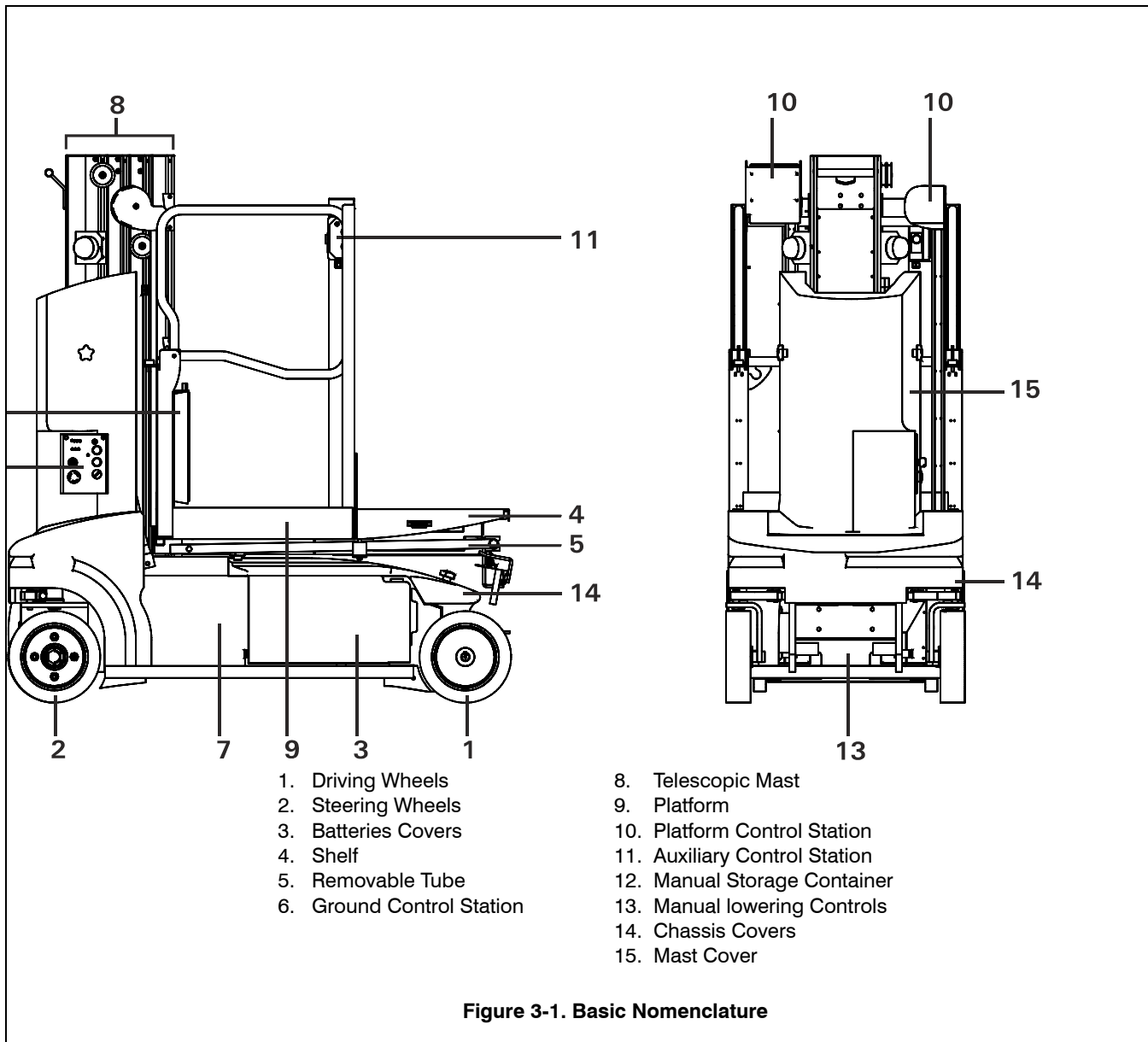

3.1 GENERAL

IMPORTANT

THE MANUFACTURER HAS NO DIRECT CONTROL OVER MACHINE APPLICATION AND OPERATION. THE USER AND OPERATOR ARE RESPONSIBLE FOR CONFORMING WITH GOOD SAFETY PRACTICES.

This section provides the necessary information needed to understand control functions.

3.2 CONTROLS AND INDICATORS

WARNING

TO AVOID SERIOUS INJURY, DO NOT OPERATE MACHINE IF ANY CONTROL LEVERS OR TOGGLE SWITCHES CONTROLLING PLATFORM MOVEMENT DO NOT RETURN TO THE OFF POSITION WHEN RELEASED.

Ground Control Station

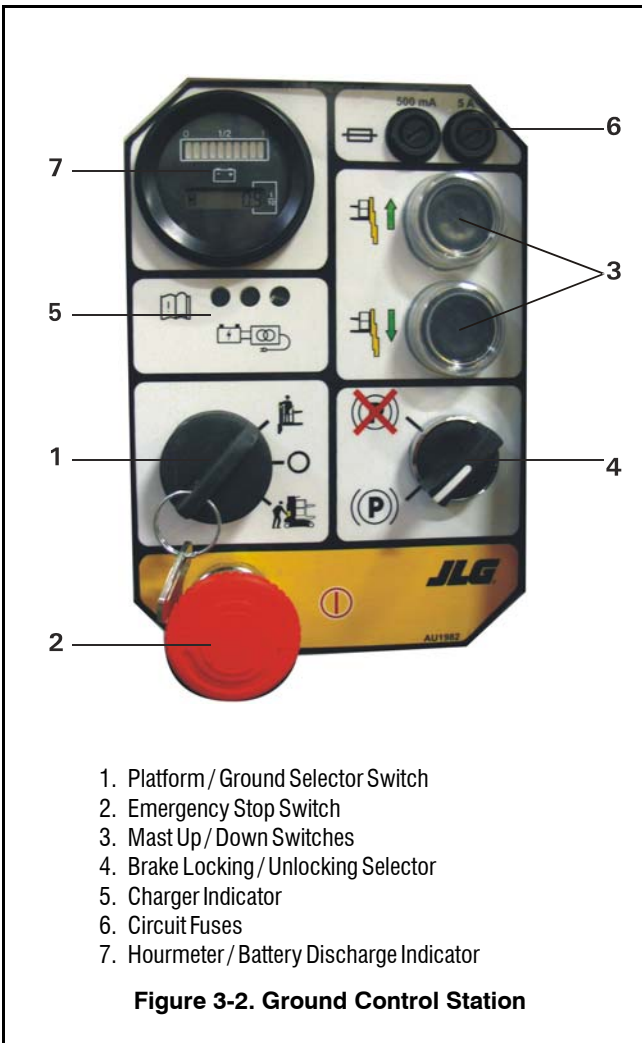

- 1. Platform / Ground Selector Switch
- 2. Emergency Stop Switch
- 3. Mast Up / Down Switches
- 4. Brake Locking / Unlocking Selector
- 5. Charger Indicator
- 6. Circuit Fuses
- 7. Hourmeter / Battery Discharge Indicator

Figure 3-2. Ground Control Station

- Wheel motor brakes released.
- Wheel motor brakes engaged.

- 5. Charger Indicator.
See § 4.6.
- 6. Circuit Fuses.
Protection of the control circuit.
- 7. Hourmeter / Battery Discharge Indicator.
As the battery discharges, the bar lit in (1) moves from the right to the left (5 green bars followed by 3 orange bars).



At this point, the LED flashes indicating "energy reserve" (70% discharged). The 2 red LEDs most to the left flash indicating "empty" (80% discharged). At this point, power is cut-off. The battery must be recharged.

- 1 - Discharge Indicator
- 2 - Hourmeter

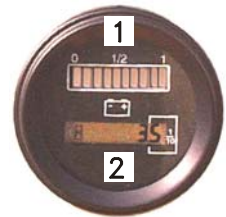

IMPORTANT

A TOTAL DISCHARGE WILL RESULT IN IRREVERSIBLE DAMAGE TO THE BATTERY.

- 1. Platform / Ground Selector Switch.



Movement Control From The Platform Controls



Control Circuit Off Position



Movement Control From The Ground Controls

- 2. Emergency Stop Switch.
Depress the switch to stop all functions. The switch must be turned clockwise to restore the machines's functions.
- 3. Mast Up / Down Switches.
Depress the switch UP to RAISE the mast.
Depress the switch DOWN to LOWER the mast.
- 4. Brake Locking / Unlocking Selector.

Manual Lowering Control

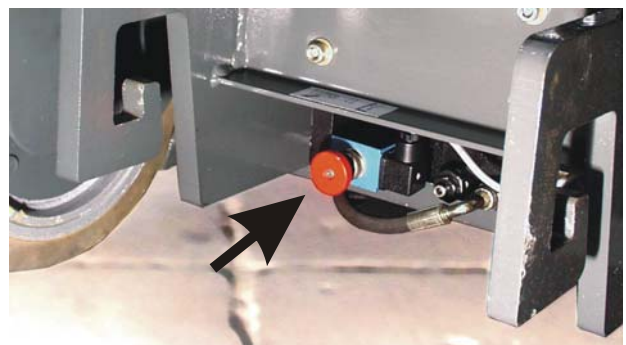

Manual Lowering Valve

Lowering Control Valve :
Pull and hold the red button to lower the mast.

Platform Control Station

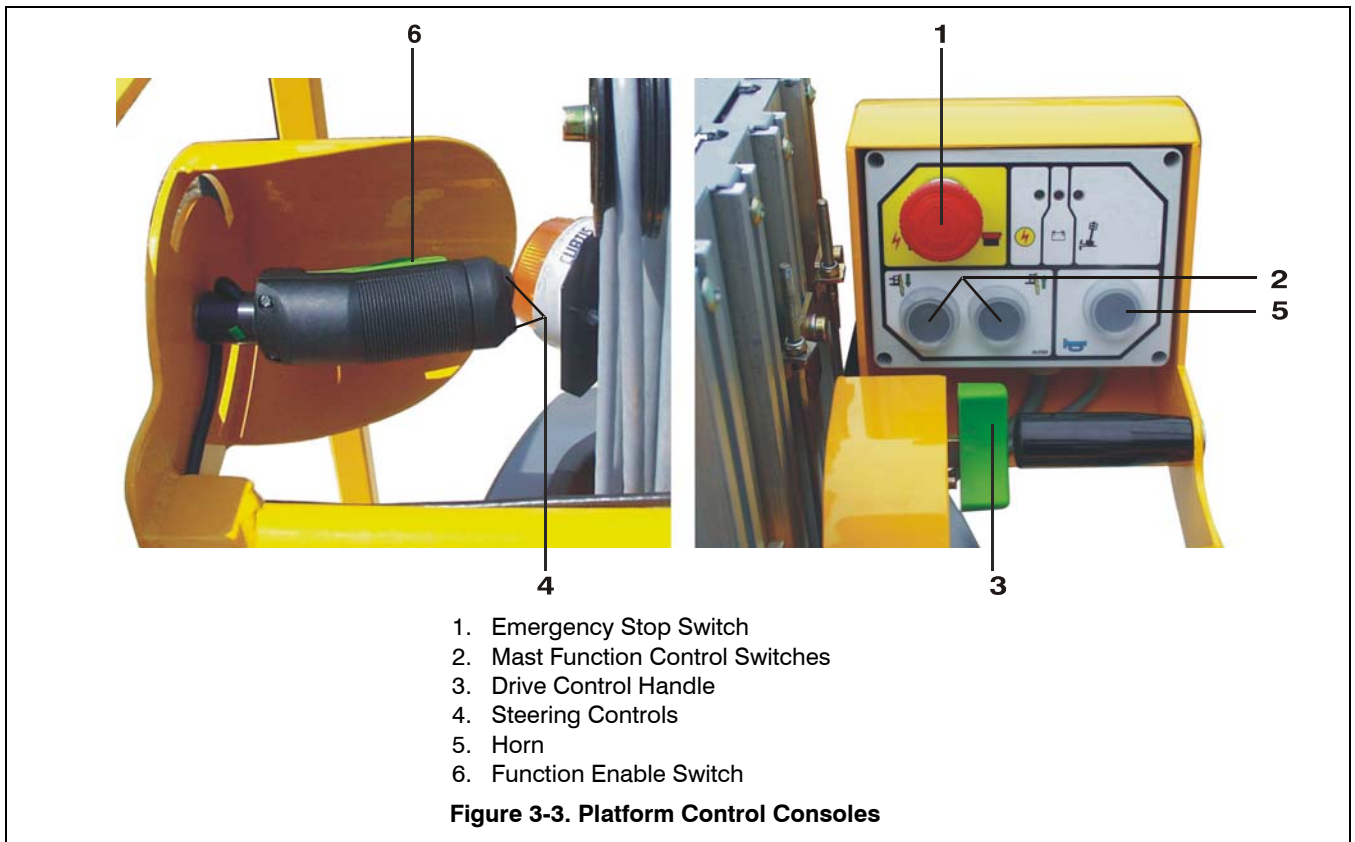

1. Emergency Stop Switch.
Depress the switch to stop all the functions of the machine. The switch must be turned clockwise to restore the machine functions.
2. Mast Function Control Switches.
Depress the right switch to raise the mast.
Depress the left switch to lower the mast.
3. Drive Control Handle
Push forward on the top of the green handle to drive forward.
Press down on the bottom of the green handle to reverse.

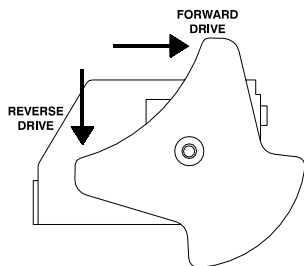

4. Steering control.
Push the top side of the thumb switch to steer the wheels to the left. Push the bottom side of the thumb switch to steer the wheels to the right.
5. Horn.
Sounds when the button is depressed.

6. Function Enable Switch



Depress trigger enable switch prior to activating a function. Releasing the switch will stop function operation.

Platform Control Indicator Panel

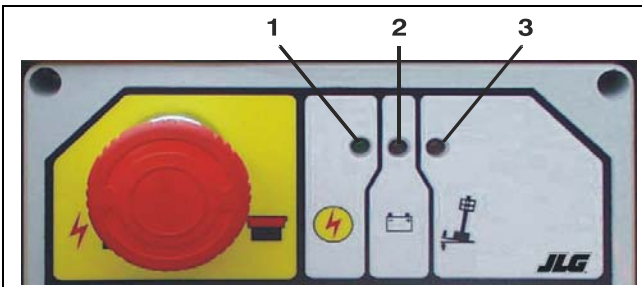

- 1. Power Enable Indicator
- 2. Battery Discharged Light And Alarm
- 3. Tilt Indicator Light And Alarm

Figure 3-4. Platform Control Indicator Panel

- 1. Power Enable Indicator.
Green light indicates that the controls are ready.
- 2. Battery Discharge Light And Alarm.
Red light indicates the battery is 80% discharged.
- 3. Tilt Indicator Light And Alarm.
Excessive tilt. Red light and audible alarm indicates the rated slope has been exceeded.

Auxiliary Control Station

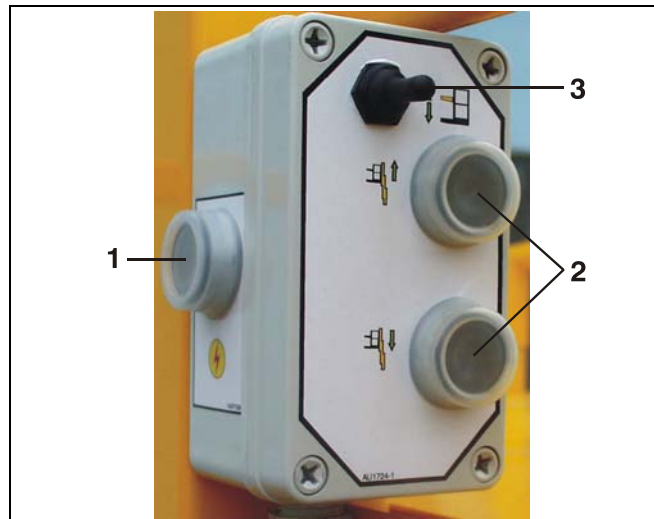

- 1. Function Enable Switch
- 2. Mast Up / Down Switches
- 3. Shelf Up / Down Switch

Figure 3-5. Auxiliary Control Console

- 1. Function Enable Switch.
Must be pushed and held to operate Mast Lift / Lower function.
- 2. Mast Up / Down Switches.
Depress the switch UP to RAISE the mast.
Depress the switch DOWN to LOWER the mast.
- 3. Shelf Up / Down Switch.
Move the switch UP to RAISE the shelf.
Move the switch DOWN to LOWER the shelf.

SECTION 4. MACHINE OPERATION

4.1 EMERGENCY CONTROL OPERATION

NOTE: A delay-timer, integrated to the electrical system, disconnects the control boxes approximately 4 hours after the last operation of the machine. This system preserves the battery should the operator forget to disconnect the machine. After cut out, the emergency stop switch on the ground control console must be depressed then turned clockwise to restore the functions of the machine.

The machine has a Ground Control Station which will override the Platform Control Stations. Ground Controls operate lift up and down and are to be used in an emergency to lower the platform to the ground should the operator in the platform be unable to do so.

Platform/Ground Select Switch

Power is supplied to the ground control station. With the switch in the ground position, power is supplied to the ground control station. When the switch is in the platform position, power is supplied to the Platform Control Stations.

Operate the ground controls as follow :



1. Position PLATFORM CONTROLS/GROUND CONTROLS selector switch to GROUND CONTROLS .
2. Activate mast function switch.

Emergency Stop Switch

This switch, when in the on (out) position, provides electrical power to the ground controls or platform controls, as applicable. In addition, the switch can be used to turn off power (push the switch IN) to the function controls in the event of an emergency.

Brake Locking / Unlocking Selector

The function for locking / unlocking the wheel motor brakes is only available if the platform ground selector switch is positioned to Ground Controls.

1. Position PLATFORM CONTROLS/GROUND CONTROLS selector switch to GROUND CONTROLS .
2. Position the selector on  to release the motor brakes for the machine to be towed. (See § 4-7 for further information).

WARNING

THE MACHINE MUST BE IN A FIRM AND LEVEL SURFACE AND IN AN AREA FREE FROM OBSTRUCTIONS.

4.2 PLATFORM CONTROLS

Traveling (Driving)

See Figure 4-1., Grade and Side Slope

NOTE: Refer to the General Specifications (Section 8) for Gradeability and Side slope ratings. All ratings for Gradeability and Side slope are based upon the machine in transport mode with the mast and shelf being in the stowed position, fully lowered.

WARNING

DO NOT DRIVE WITH MAST AND SHELF OUT OF TRANSPORT MODE EXCEPT ON A SMOOTH, FIRM AND LEVEL SURFACE.

TO AVOID LOSS OF TRAVEL CONTROL OR "TIP OVER", DO NOT DRIVE MACHINE ON GRADES EXCEEDING THOSE SPECIFIED IN SECTION 8 OF THIS MANUAL. USE EXTREME CAUTION WHEN DRIVING IN REVERSE AND AT ALL TIMES WHEN THE PLATFORM IS ELEVATED.

With the machine in transport mode, traveling is limited by two factors, gradeability and side slope. Gradeability is the percent of grade of the incline the machine can climb. Sideslope, is the angle of the slope the machine can be driven across. Reference section 8 for gradeability and side slope ratings.

When the mast is extended, the machine must not be operated on grades or side slopes that are greater than that specified in Section 8. The tilt alarm will sound and tilt indicator will light to alert the operator when the machine has exceeded the rated slope. The drive and mast raising movements are cut.

Figure 4-1. Grade and Side Slope

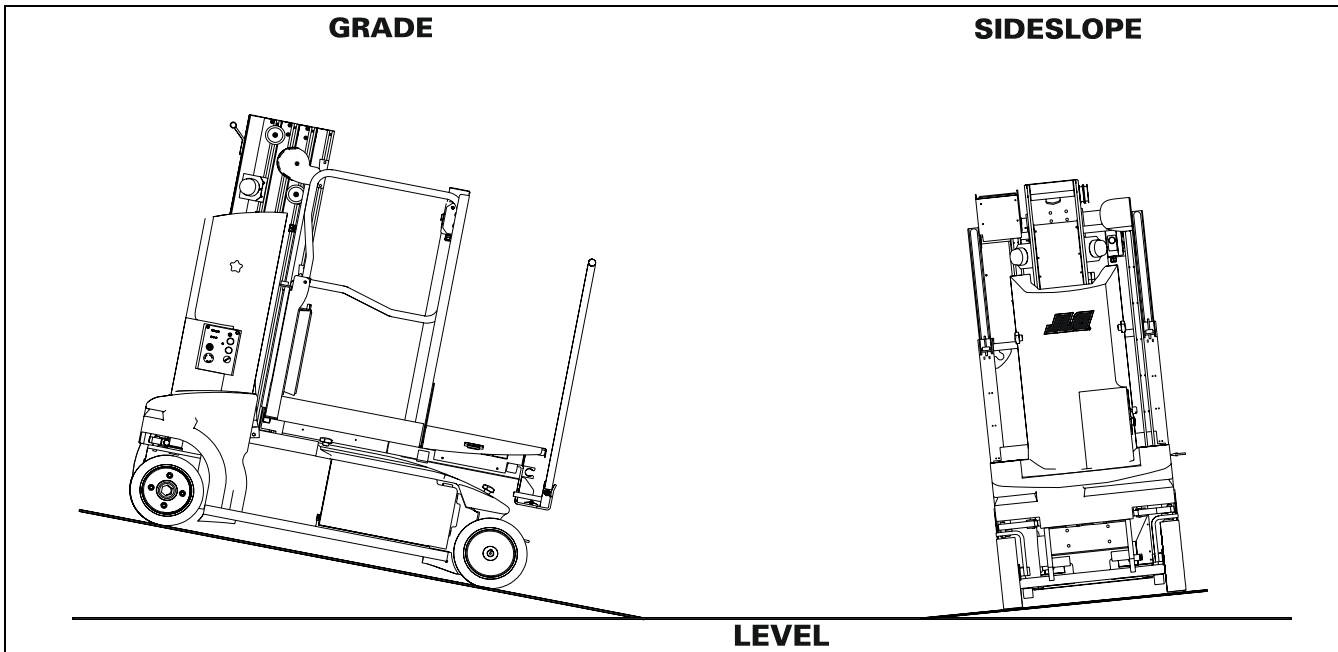

Forward

1. Squeezed and hold the function enable switch.
2. Press on the top of the drive handle within 5 seconds after the function enable switch has been actuated.

Stopping

Stopping is accomplished by slowly returning the drive handle to the neutral position. The brakes will apply automatically.

Reverse

Traveling in reverse is accomplished the same way as traveling forward except for pressing on the the bottom of the drive handle to reverse.

Steering

Steering is accomplished by pressing the top side of the THUMB switch (on top of the controller) to steer to the left or the bottom side of the THUMB switch (on top on the controller) to steer to the right.

⚠ WARNING

TO AVOID TIP OVER, LOWER PLATFORM TO GROUND LEVEL. THEN DRIVE MACHINE TO A LEVEL SURFACE BEFORE RAISING MAST.

TO AVOID SERIOUS INJURY, DO NOT OPERATE MACHINE IF ANY CONTROL LEVER OR TOGGLE SWITCH CONTROLLING PLATFORM MOVEMENT DOES NOT RETURN TO THE 'OFF' OR NEUTRAL POSITION WHEN RELEASED.

IF THE PLATFORM DOES NOT STOP WHEN A CONTROL SWITCH OR LEVER IS RELEASED, REMOVE HAND FROM TRIGGER OR USE EMERGENCY STOP SWITCH TO STOP THE MACHINE.

Raising And Lowering Mast

Raising the mast :

1. Squeeze and hold the function enable switch on the platform control or push and hold the enable switch on the Auxiliary Control Station.
2. Push the mast raising function control switch to raise the mast within 5 seconds after the function enable switch has been actuated.

Lowering the mast :

1. Squeeze and hold the function enable switch on the platform control or push and hold the enable switch on the Auxiliary Control Station.
2. Push the mast lowering function control switch to lower the mast within 5 seconds after the function enable switch has been actuated.

Raising And Lowering Shelf

Raising the shelf :

1. Pull up the shelf function control switch to raise the shelf.

Lowering the shelf :

1. Push down the shelf function control switch to lower the shelf.

Work Platform Functions Combination

A drive movement cannot be combined with a structure movement.

If a drive movement and a structure movement are controlled simultaneously, only the structure movement shall occur. The drive movement will be accomplished as soon as the structure movement is released.

4.3 MANUAL LOWERING CONTROLS

The manual lowering controls should be used in emergency situations or mechanical breakdown. The manual lowering controls provide an auxiliary mean of lowering the platform in the event of primary power loss.

4.4 ALARMS

Horn

Activated when the corresponding push button located on the Platform Control Console is depressed.

Motion Alarms

The machine is fitted with 2 lights (beacons) and with an acoustic alarm that come on as soon as a function is controlled (not including shelf) from the platform control panels.

Tilt Light And Alarm

The alarm is triggered by a tilt sensor located on the center of the chassis under the chassis cover. This alarm is active once the mast has left its lowered position, as soon as the machine is over 2 degrees off the horizontal. It consists of a light on the platform control panel and an audible alarm. The alarm and light indicate that the work platform is at its maximum out of level limit and is nearing an unstable position. Drive and mast raising function are disabled. Do not activate any function other than those necessary to return the machine in a more stable configuration. It is recommended to lower the platform and reposition the machine on a level surface.

WARNING

DO NOT ACTIVATE ANY FUNCTION OTHER THAN THOSE NECESSARY TO RETURN THE MACHINE IN A MORE STABLE CONFIGURATION WHEN THE MACHINE IS OUT OF LEVEL.

4.5 SHUT DOWN AND PARK

To shut down and park the machine, the procedures are as follow :

1. Drive machine to a reasonably well protected area.
2. Ensure mast is lowered.
3. Ensure shelf is lowered and removable tube stored under the platform.
4. Push in the Emergency Stop at Platform Control Station.
5. Push in the Emergency Stop at Ground Control Station. Position Platform/Ground select switch to center OFF and remove key to prevent unauthorised use.
6. If necessary, cover Platform Controls to protect instruction placards, warning decals and operating controls from hostile environment.
7. Charge the battery, if necessary.

4.6 CHARGER

The on-board electronic charger is designed to automatically charge 24 V DC rechargeable batteries. The covers of the machine must be open during battery charge.

WARNING

LEAD-ACID BATTERIES MAY EMIT HIGHLY EXPLOSIVE GASES. THE EMISSION IS GREATLY INCREASED DURING CHARGING. NEVER INTRODUCE FLAMES, SPARKS, OR OTHER SOURCES OF IGNITION TO BATTERY AREA. FAILURE TO COMPLY WITH THIS WARNING COULD RESULT IN DEATH OR INJURY TO PERSONNEL. ALWAYS CHARGE BATTERIES IN A WELL-VENTILATED AREA.

WARNING

DO NOT DISCONNECT BATTERY PLUG WHEN THE CHARGER IS ON. THE RESULTING ARCING COULD CAUSE BATTERY TO EXPLODE AND BURNS TO THE OPERATOR.

NOTE: *When the charger is connected to the power supply, all functions are cut out.*

NOTE: *If power supply is stopped during the charge cycle, the charger switches to a waiting mode and restarts automatically as soon as the power returns.*

Charger voltage :

The charger is designed to work with a network voltage of 110 VAC or 220 VAC. It is fitted with an automatic switching device function of the applied network voltage.

TECSUP High Frequency Electronic Charger

Charging the battery :

- Plug the charger into a grounded 110/220 V AC electrical outlet.
- The charger starts automatically.

NOTE: The charger power plug is fitted at the end of a 16' 5" (5 m) cable, housed in an automatic reel. This reel is equipped with a circuit breaker that protects the rings and brushings (see photo below).

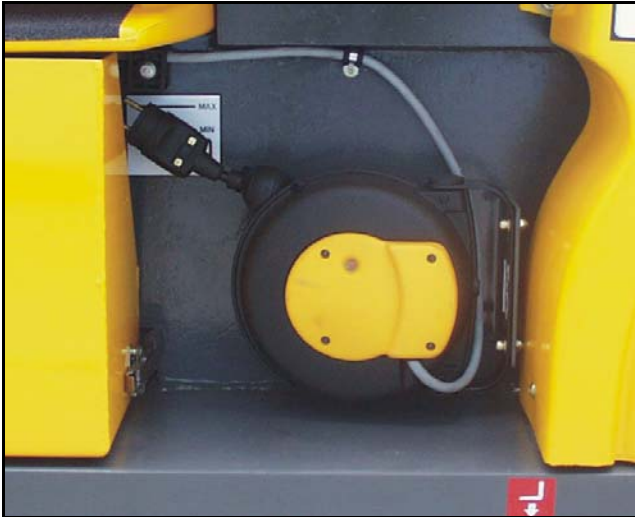

NOTE: If the circuit-breaker trips, depress the reset button to allow battery charge.

Charging phase indicator on the ground control station :

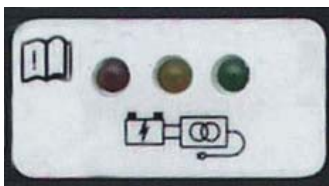

Red LED (Default):

-LED flashing : charger excessive temperature (the charger will stop if the temperature exceeds 212°F (100°C)).

-LED fixed : deep battery discharge (U_{batt} < 18 V). If the voltage remains below 18 V for over 5 minutes, the charger switches off automatically. To resume operation, unplug it from the power source and wait for approximately 10 minutes before restarting it.

Yellow LED (Charge) :

-This LED is lit as long as the battery is not fully charged.

Green LED (100 %) :

-This LED is lit when the battery is fully charged.



4.7 EMERGENCY TOWING

Towing is discouraged and must only be performed as a last option.

IMPORTANT

VERIFY THE CAPACITY OF THE EQUIPMENT USED TO TOW THE MACHINE.

To tow, release the brakes and the wheel motors as follow :

1. Fully lower the machine.
2. Position Platform Controls / Ground Controls selector switch to Ground Controls ().
3. Position the brake release selector to Brakes Released ().
4. Use a winch to tow the machine (if a winch is not available, use another low speed towing device). There are two tie down/emergency tow lugs installed at the front of the chassis of the work platform. When using these lugs, always tow using both lugs.
5. At the end of the procedure, return the release selector to NORMAL USE (). The machine and the brakes are operational.

CAUTION

IT IS IMPOSSIBLE TO RELEASE THE WHEEL MOTOR BRAKES IF THE MACHINE'S BATTERIES ARE COMPLETELY DISCHARGED.

WARNING

MACHINE HAS NO TOWING BRAKES. TOWING VEHICLE MUST BE ABLE TO CONTROL MACHINE AT ALL TIMES, ON-HIGHWAY TOWING NOT PERMITTED, FAILURE TO FOLLOW INSTRUCTIONS COULD CAUSE SERIOUS INJURY OR DEATH. MAXIMUM TOWING GRADE 20%.

WARNING

BEFORE TOWING THE MACHINE, THE BRAKES AND THE WHEEL MOTORS MUST BE RELEASED. TOWING IS LIMITED TO EXTREMELY SHORT DISTANCES AT A MAXIMUM SPEED OF 0.6 MPH (1 KM/H). SEVERE DAMAGE TO THE DRIVE SYSTEM MAY RESULT IF TOWING IS OTHERWISE ACCOMPLISHED.

WARNING

ENSURE THE MACHINE IS ON LEVEL GROUND BEFORE RELEASING THE BRAKES. THE MACHINE MUST ALWAYS BE IN STOWED POSITION DURING TOWING PROCEDURE.

WARNING

NO PERSONNEL ARE ALLOWED ON THE PLATFORM DURING TOWING PROCEDURE.

4.8 LIFTING AND TIE DOWN

IMPORTANT

WHEN TRANSPORTING THE MACHINE, THE MACHINE MUST BE STOWED.

Lifting

1. The weight of the machine is stamped on the serial number plate (See § 8.2). If the plate is missing or illegible, call JLG or weigh the individual unit to find out the Gross Vehicle Weight.
2. Place the machine in the stowed position.
3. Remove all loose items from the machine.
4. Attach lifting device and equipment only to the designated lifting point (See below).

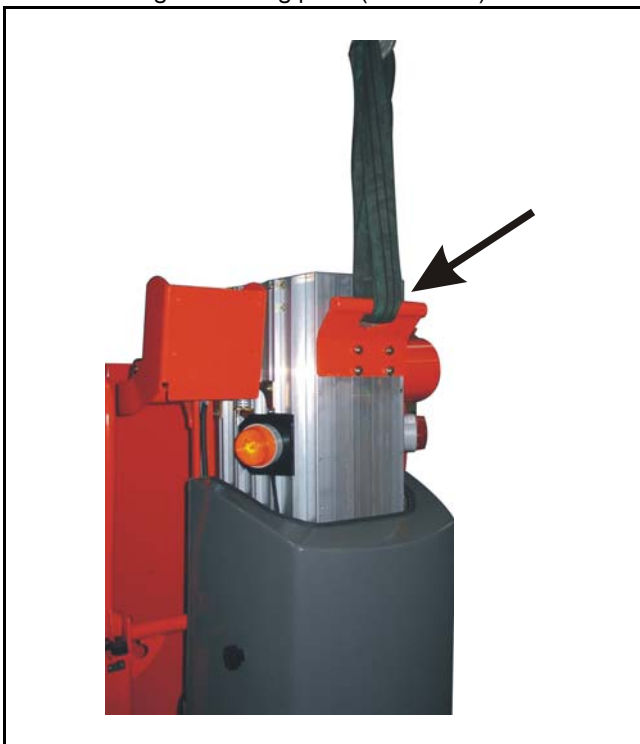

5. Properly adjust the rigging to prevent damage to the machine.

Tie Down

1. Place the machine in the stowed position and chock wheels in both directions.
2. Remove all loose items from the machine.
3. Secure the chassis using straps or chains of adequate strength and attached to the designated tie down points.

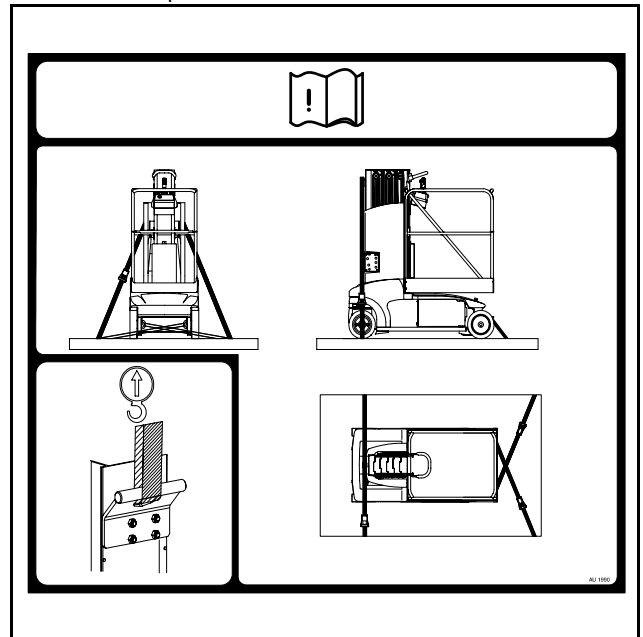

4.9 LOADING AND UNLOADING

Using a fork lift truck



Figure 4-2. Position of the forks

⚠ CAUTION

VERIFY THE CAPACITY OF THE FORKLIFT TRUCK AND OF ITS EQUIPMENT. FORK LIFT ONLY AT THE DESIGNATED POINTS. ANY OTHER POSITION OF THE FORKS WILL CAUSE THE MACHINE TO TIP OVER. NOBODY CAN BE ON THE PLATFORM OF THE MACHINE DURING LOADING AND UNLOADING OPERATIONS.

⚠ WARNING

THE WORK PLATFORM MUST BE KEPT AS NEAR TO THE GROUND AS POSSIBLE DURING FORK LIFT OPERATION.

Using a winch for loading

If the work platform cannot be loaded safely using the work platform controls, a winch may be used. The brakes must be released prior to winching.

⚠ CAUTION

CHECK THE CAPACITY OF THE EQUIPMENT USED. NOBODY CAN BE IN THE PLATFORM DURING THIS OPERATION.

SECTION 5. DECALS

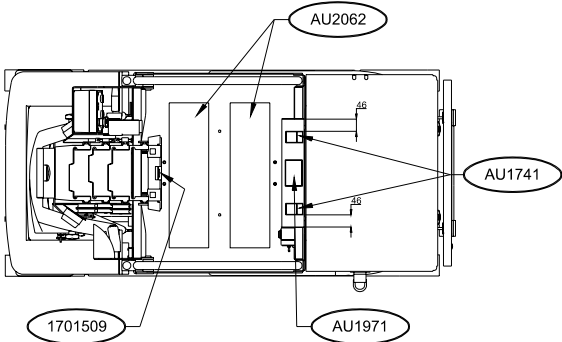
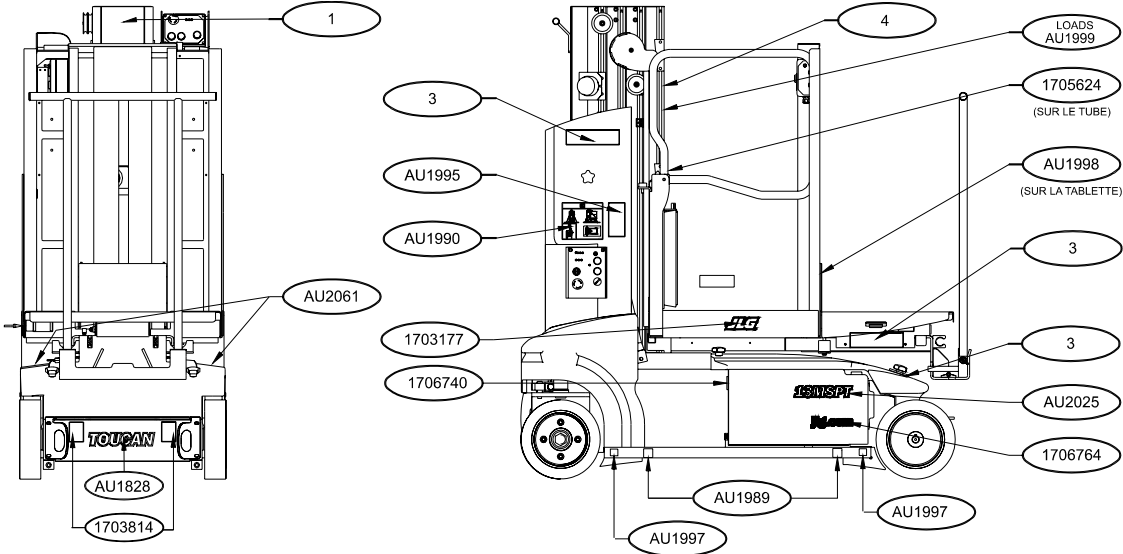

1	AU1996
2	1703785
3	1703786
4	1704366

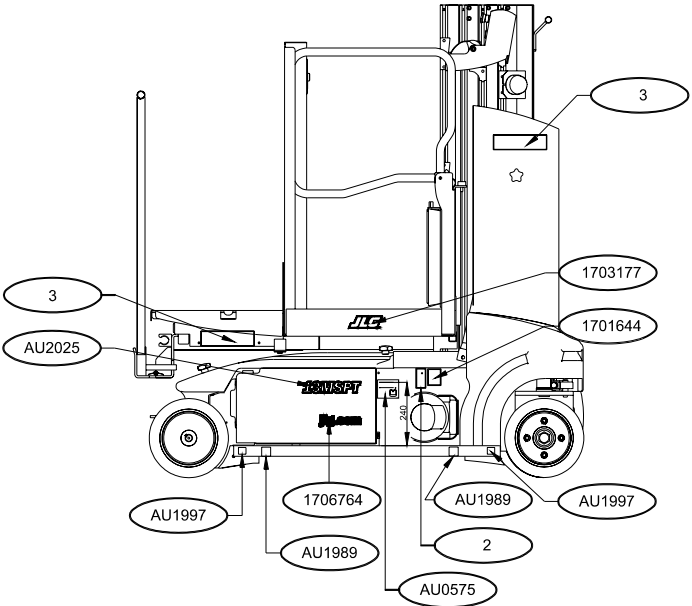
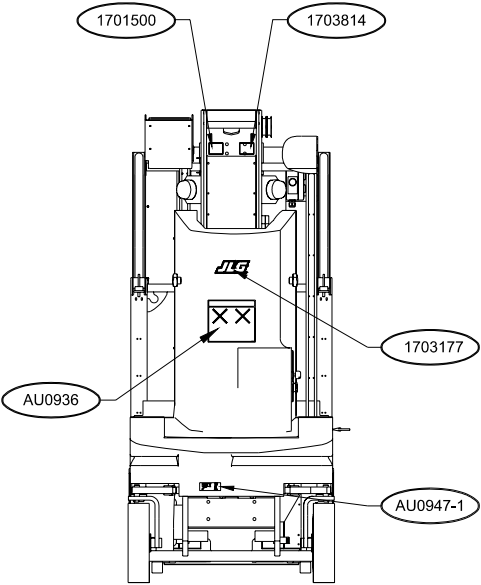

SECTION 6. EMERGENCY PROCEDURES

6.1 GENERAL

This section explains the steps to be taken in case of an emergency situation while operating.

6.2 INCIDENT NOTIFICATION

JLG Industries, Inc. must be notified immediately of any incident involving a JLG product. Even if no injury or property damage is evident, the factory should be contacted by telephone and provided with all necessary details.

In USA : 877-JLG-SAFE (Toll free)

Outside USA: 717-485-5161 or 717-485-6591

E-mail:ProductSafety@JLG.com

Failure to notify the manufacturer of an incident involving a JLG Industries product within 48 hours of such an occurrence may void any warranty consideration on that particular machine.

IMPORTANT

FOLLOWING ANY ACCIDENT, THOROUGHLY INSPECT THE MACHINE AND TEST ALL FUNCTIONS FIRST FROM THE GROUND CONTROLS, THEN FROM THE PLATFORM CONTROLS. DO NOT CONTINUE TO OPERATE MACHINE UNTIL YOU ARE SURE THAT ALL DAMAGE HAS BEEN REPAIRED, IF REQUIRED, AND THAT ALL CONTROLS ARE OPERATING CORRECTLY.

6.3 EMERGENCY OPERATION

Operator Unable to Control Machine

IF THE PLATFORM OPERATOR IS PINNED, TRAPPED OR UNABLE TO OPERATE OR CONTROL MACHINE:

1. Other personnel should operate the machine from ground controls only as required.
2. Other qualified personnel on the platform may use the platform controls. DO NOT CONTINUE OPERATION IF CONTROLS DO NOT FUNCTION PROPERLY.
3. Appropriate equipment can be used to remove platform occupants and stabilize motion of the machine.

Platform or Mast Caught Overhead

If the platform or mast becomes jammed or snagged in overhead structures or equipment, rescue platform occupants prior to freeing the machine.

6.4 EMERGENCY LOWERING

If primary power is lost, the platform may be lowered manually. Reference section 3 for Manual Lowering Control procedure.

6.5 EMERGENCY TOWING PROCEDURES

Towing this machine is discouraged. However, provisions for towing the machine in emergency situations have been incorporated. For specific procedures, refer to Section 4.

SECTION 7 - INSPECTION AND REPAIR LOG

SECTION 8. GENERAL SPECIFICATIONS & OPERATOR MAINTENANCE

8.1 INTRODUCTION

This section of the manual provides additional necessary information to the operator for proper operation and maintenance of this machine.

The maintenance portion of this section is intended as information to assist the machine operator to perform daily maintenance tasks only, and does not replace the more thorough Preventive Maintenance and Inspection Schedule included in the Service and Maintenance Manual.

Other Publications Available :

Service and Maintenance Manual 31210003

Illustrated Parts Manual 31210004

8.2 OPERATING SPECIFICATIONS

Table 8-1. Operating Specifications And Dimensions

Maximum Work Load On The Platform	285 lbs	130 kg
Maximum Work Load On The Shelf	150 lbs	70 kg
Maximum Number of Occupants for Machine	1	
Max. Platform Height	13'1"	4 m
Max. Hydraulic System Pressure	2175 Psi	15 Mpa
Maximum Horizontal Manual Side Force	50 lbf	222 N
Electrical System Voltage	24 VDC	24 V
Gross Machine Weight (Platform Empty)	2270 lbs	1030 kg
Overall Length	5'5"	1.65 m
Overall Height	5'10"	1.79 m
Overall Width	2'7"	0.78 m
Maximum Wheel Load	1212 lbs	550 kg
Maximum Travel Grade (Gradeability)	20%	20%
Tilt Sensor Setting	1.8° ± 0.2°	
Turning Radius		
Inside :	0'	0
Outside :	5'5"	1.64 m

Fluid Capacities

Table 8-2. Capacities

Main Hydraulic Tank	1.3 gal	5 l
Shelf Unit	0.26 gal	1 l

Electric Power Units

Table 8-3. Electric Power Units Specifications

			Maximum 2175 Psi	Maximum 150 Bar
Main Power Unit	Motor	Power	1 kW	1 kW
		Voltage	24 VDC	24 VDC
	Pump	Flow rate	1.3 Gal/min	4.8 l/mn
		Displacement	0.076 cu.in/rev	1.25 cm³/t
Steering Unit	Motor	Power	0.8 kW	0.8 kW
		Voltage	24 VDC	24 VDC
	Pump	Displacement	0.03 cu.in/rev	0.5 cm³/t

Batteries

Table 8-4. Battery Specifications

Voltage	24 Volt
Amp Hour Rating	180Ah (5h rate)

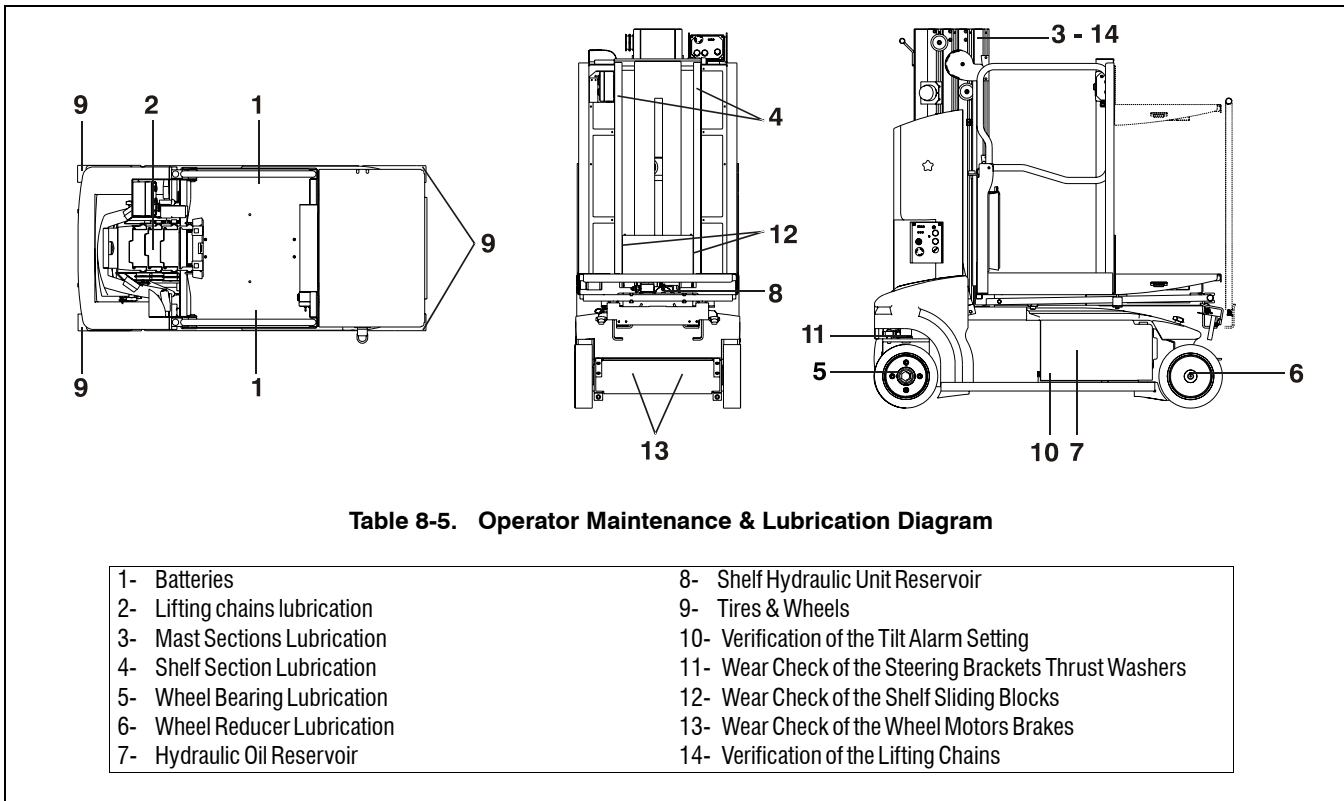

8.3 OPERATOR MAINTENANCE

1. Batteries

Cleaning - Battery maintenance

It is necessary to clean the battery regularly to prevent salt formation and current arcing which could damage the machine.

- Clean the battery top with a damp cloth.
- Allow to dry and wipe the battery top with a dry non-fluffy rag.
- Ensure connections are clean and tight.

NOTE: Coat the terminals and connections with an anti-corrosion compound or grease.

- Keep the metallic containers clean. in case of corrosion, clean, neutralize corrosion and apply anti-acid paint on the affected area.
- Drain the water that can accumulate at the bottom of the container (battery cleaning...)

⚠ DANGER

DRAINED WATER MAY HAVE BEEN IN CONTACT WITH ACID AND MAY HAVE BECOME CORROSIVE. DO NOT ALLOW DRAIN WATER TO CONTACT THE SKIN OR EYES. IF IT OCCURS, FLUSH THE CONTACTED AREA WITH WATER AND CONSULT A DOCTOR IMMEDIATELY. APPROPRIATE EQUIPEMENT MUST BE WORN (GLOVES,GOGGLES, RUBBER APRON) TO PREVENT THE

DRAINED WATER FROM CONTACTING THE SKIN OR ANY PART OF THE BODY.



Battery voltage

Voltage measures are the most important checks to be performed on a vented battery.

Voltage readings must be performed at least once a month and recorded in a battery service log.

⚠ DANGER

BATTERY ELECTROLYTE MUST NOT BE ALLOWED TO CONTACT THE SKIN OR EYES. IF IT DOES OCCUR, FLUSH THE CONTACTED AREA WITH WATER AND CONSULT A DOCTOR IMMEDIATELY. APPROPRIATE EQUIPMENT MUST BE WORN (GLOVES, GOGGLES, RUBBER APRON) TO PREVENT THE ELECTROLYTE FROM CONTACTING THE SKIN OR ANY OTHER PART OF THE BODY DURING ANY SERVICING OPERATION ON THE BATTERY.

⚠ DANGER

DURING MAINTENANCE OR NAY SERVICING OPERATION ON THE BATTERY, RINGS, WATCHES OR ANY OTHER JEWELLERY MUST BE REMOVED.

Use of a battery in a cold chamber or in a cold climate

Low temperatures decrease battery capacity. The battery must be fully charged when the work platform is operated in a cold chamber or in cold weather condition.

⚠ CAUTION

IF THE BATTERY IS NOT USED CONTINUOUSLY, IT MUST BE RECHARGED BEFORE USE AND AT LEAST ONCE A MONTH, EVEN IF THE ELECTROLYTE SPECIFIC GRAVITY MEASURES ARE HIGH.

Battery not working continuously or inactive battery

A battery that is not used or used intermittently must be stored charged in a dry area away from freezing temperatures. A charge must be performed once a month. (In these conditions battery storage is possible at temperatures of 30°C (86° F) for a 12 month period.

⚠ CAUTION

BEFORE PLACING IN SERVICE A BATTERY WHICH REMAINED INACTIVE FOR A LONG PERIOD OF TIME, YOU MUST RECHARGE THE BATTERY AND CHECK THE ELECTROLYTE LEVEL IN THE CELLS.

⚠ CAUTION

STORING A DISCHARGED BATTERY WILL RESULT IN IRREVERSIBLE DAMAGE TO THE BATTERY.

- Unplug the battery to insulate it electrically.
- Keep the top of the battery clean and dry to prevent self discharge : during inactivity periods, battery loose their charge progressively (auto-discharge). Auto-discharge causes battery plates corrosion, which increases with time, resulting in battery malfunction.

Battery troubleshooting

Symptoms	probable causes	solutions
Low voltage in the cells in open circuit	Electrolyte specific gravity too low	Charge battery
	Short-circuit	Clean battery top
Battery cell too high (over 113°F (45°C))	Problem with the charger	Get the charger checked by a technician
	Bad air circulation during charge	Open access doors to batteries during charge Reduce temperature of the area where the battery is charged (artificial ventilation)
	Cell weak or faulty Cells shorty	Change battery cell
Battery incapable of supporting regular operation	Battery under charged	Charge battery
	Cell faulty	Replace faulty cell
	Faulty cable or connection	Check wire condition and connection
	Battery at the end of its service life	Replace the battery

Lubrication Specification

A	NERVOL - AGROFLUID DVG 32
	MOBIL DTE FM 32
	FOOD COMPATIBLE
B	COMPLEX EP2
	MOBILUX EP2
C	SHELL ALVANIA RA
D	MOBIL DTE 16M
	CHAINE FILANTE
E	MOBILUX EP2
	COMPLEX EP2

NOTE: Aside from JLG recommendations, it is not advisable to mix oils of different brands or types, as they may not contain the same required additives or be of comparable viscosities. If use of hydraulic oil or grease other than recommended in the previous chart, contact JLG Industries for proper recommendations.

IMPORTANT

LUBRICATION INTERVALS ARE BASED ON MACHINE OPERATION UNDER NORMAL CONDITIONS. FOR MACHINES USED IN MULTI-SHIFT OPERATIONS AND/OR SEVERE ENVIRONMENTS, LUBRICATION FREQUENCY MUST BE INCREASED ACCORDINGLY.

2. Lifting Chains Lubrication

Lube - TYPE D
 Interval - every 125 hours or once every 30 days of operation.
 Comments - Lubricant can be applied manually with a brush or by spraying. Apply lubricant :
 - Longitudinally : in areas where joints are under small load to facilitate penetration of the lubricant.
 - Transversally : between the plates to enable the lubricant to reach the joint and between the internal plates and the rollers.

Temperature		Recommended viscosity grades ISO - VG
C°	F°	
-15 < T ≤ 0	5 < T ≤ 32	15 to 32
0 < T ≤ 50	32 < T ≤ 122	46 to 150
50 < T < 80	122 < T < 176	220 to 320

3. Mast Sections Lubrication

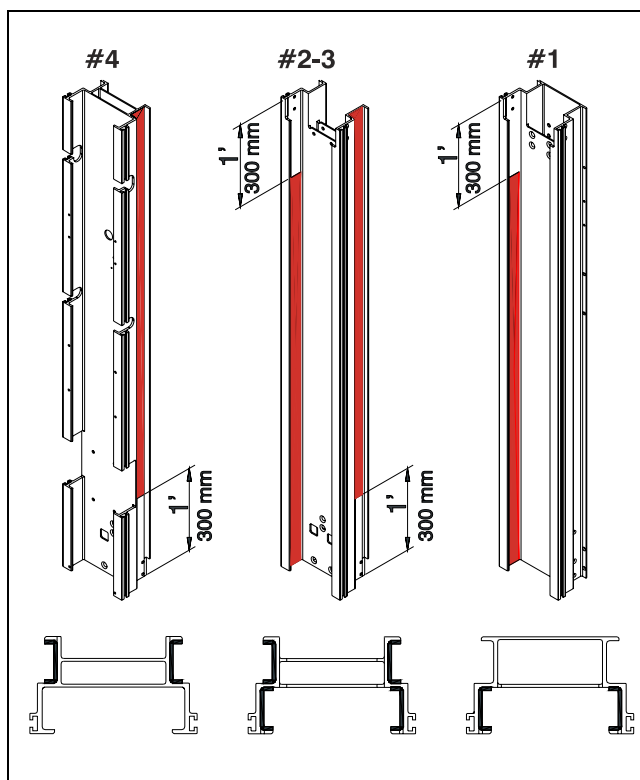

Lube - TYPE B
 Interval - every 125 hours of operation or after each cleaning.
 Comments - Clean the inside wall of mast to remove the old grease. Lubricate the mast inside wall using a brush.

4. Shelf Section Lubrication

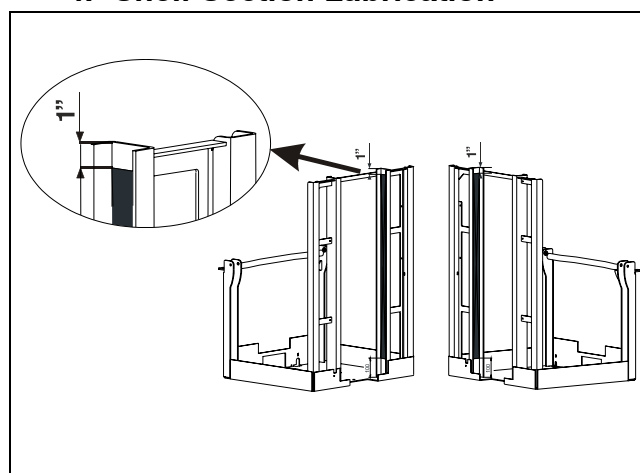

Lube - TYPE B
 Interval - every 125 hours of operation or after each cleaning.
 Comments - Clean the inside wall of shelf to remove the old grease. Lubricate the shelf inside wall using a brush.

5. Wheel Bearing Lubrication

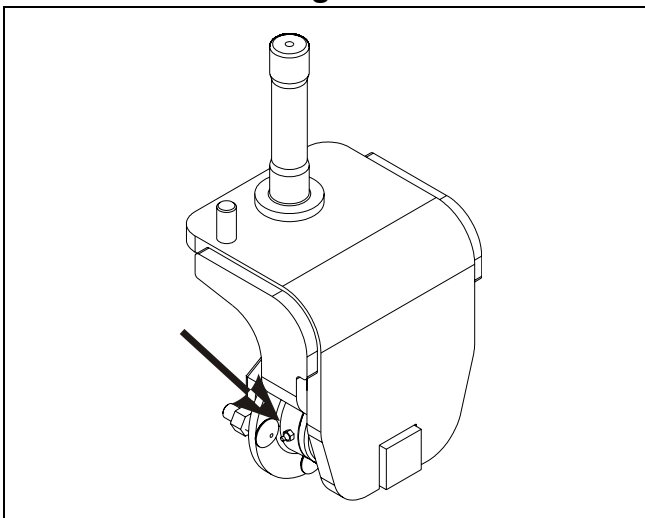

Lube point(s) - 1 Grease Fitting
 Lube - TYPE E
 Interval - every 250 hours of operation.
 Comments - One fitting on each hub. Remove the wheel to gain access to the grease fitting.

6. Wheel Reducer Lubrication



Lube point(s) - 1 Reducer Cap
 Lube - TYPE C
 Interval - The reducers are greased for life. If the reducers are not be used for over a year, refer to the Service Manual for lubrication procedure.

7. Hydraulic Oil Reservoir



Lube Point(s) - Breather cap
 Capacity - 1,3 Gallon (5 liters)
 Lube - TYPE A
 Interval - Check oil daily, change after every 1000 hours of operation or at least every 2 years.

Reservoir Draining :

- a. Remove the rear cover.
- b. Remove the quick pressure plug from the hydraulic power unit.
- c. Install a hose on its place. Position the free end of the hose in a container of a 1,6 gallon (6 liters) minimum capacity.
- d. Position the Platform / Ground selector switch to Ground Control Station. Depress the mast elevation switch until the oil in the reservoir reaches the level indicated below.

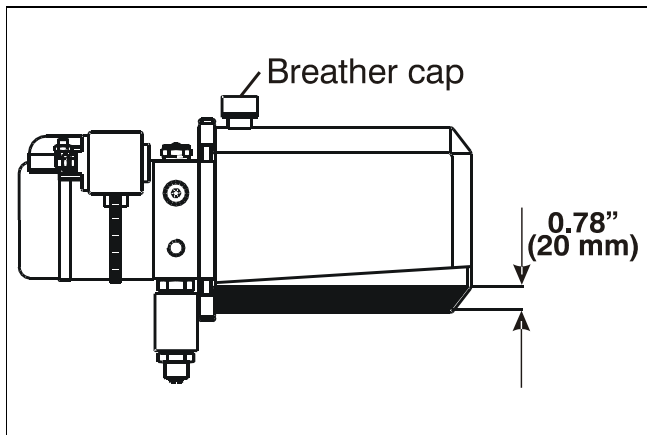

NOTE: Do not let the oil spill on the work platform or on the ground.

- e. Replace the hose by the original quick pressure plug.

Reservoir Filling :

- f. Remove the rear cover, if necessary and remove the breather cap from the reservoir.
- g. Fill the reservoir with new hydraulic oil up to the appropriate level (see below). Do not exceed maximum level.

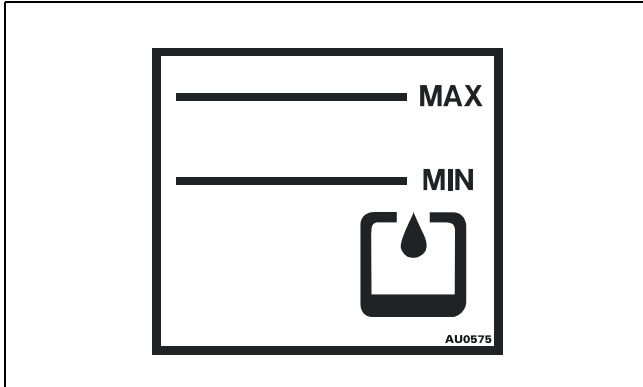

- h. Install the breather cap and the rear cover.
- i. Bleed the mast cylinder. Lift the mast several times up to 6' (2 m) to check the machine's good working order and absence of leaks.
- j. If necessary, add hydraulic oil without exceeding the maximum level indicated.

8. Shelf Hydraulic Unit Reservoir

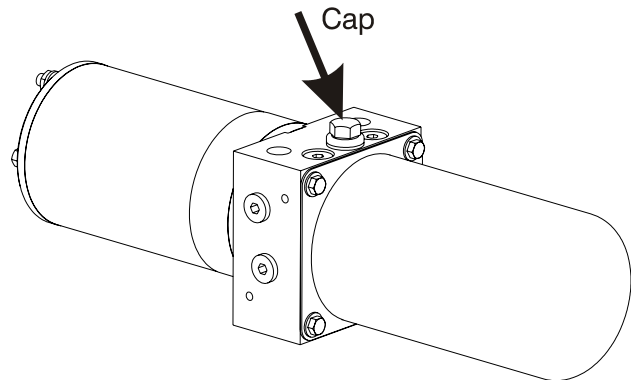

Lube Point(s) - Breather Cap

Capacity - 1 liter

Lube - TYPE A

Interval - Check after every 125 hours of operation.

Drain after 1000 hours of operation or at least every 2 years.

Reservoir Draining :

- a. Remove the rear cover.
- b. Tag and disconnect electrical cables from the hydraulic unit motor.
- c. Tag and disconnect the hydraulic lines from the hydraulic unit output. Cap the hydraulic lines and the unit port holes.

⚠ WARNING

HIGH PRESSURE OIL COULD PENETRATE SKIN AND CAUSE INJURIES OR BURNS. LOOSEN THE HYDRAULIC CONNECTIONS VERY SLOWLY TO ALLOW THE PRESSURE TO DROP GRADUALLY.

NOTE: Use a container to collect the oil from the hydraulic lines or from the hydraulic group and prevent it from spilling on the work platform or on the ground.

- d. Remove the hydraulic unit.
- e. Place the hydraulic unit above a container, open the filling hole and turn the group upside down to drain the oil from the reservoir.
- f. Wipe the outside of the group with a non fluffy rag.
- g. Install the hydraulic unit, reconnect the hydraulic lines and the electrical cables.
- h. Used oils must be disposed of according to regulations in force.

Reservoir Filling :

IMPORTANT

THE SHELF CYLINDER MUST BE FULLY RETRACTED (SHELF LOWERED) WHEN THE TANK IS FILLED OR THE OIL LEVEL CHECKED.

- i. Unscrew the filling cap and fill the tank with new oil until the oil level is visible through the filling hole.
- j. Install the cap and perform a few shelf movements to bleed the air from the hydraulic circuit.

NOTE: Tighten the hydraulic lines as soon as the oil starts flowing out.

- k. Add oil in the tank if necessary with the SHELF CYLINDER FULLY RETRACTED.

9. Tires and Wheels

Tire wear and damage :

Inspect tires periodically for wear or damage. Tires with worn edges or distorted profiles require replacement. Tires with significant damage in the tread area or side wall, require immediate evaluation before placing the machine into service.

Wheel installation :

It is extremely important to apply and maintain proper wheel mounting torque.

⚠ WARNING

WHEEL NUTS AND SCREWS MUST BE INSTALLED AND MAINTAINED AT THE PROPER TORQUE TO PREVENT LOOSE WHEELS, BROKEN STUDS AND POSSIBLE SEPARATION OF WHEEL FROM THE AXLE. BE SURE THAT THE LUG NUTS AND SCREWS ARE SEATED PROPERLY TO THE WHEEL.

IMPORTANT

TIGHTEN THE NUTS AND BOLTS USING A TORQUE WRENCH.

Tighten the lug nuts and bolts to the proper torque to prevent wheels from coming loose. If you do not have a torque wrench, tighten the fasteners with a lug wrench, then immediately have a service garage or dealer tighten the lug nuts to the proper torque. Overtightening will result in breaking the studs or permanently deforming the mounting stud holes in the wheels. The proper procedure for attaching wheels is as follows :

- Start all nuts and bolts by hand to prevent cross threading. DO NOT use a lubricant on threads or nuts.

Front wheels :

- Tighten nuts in the following sequence :

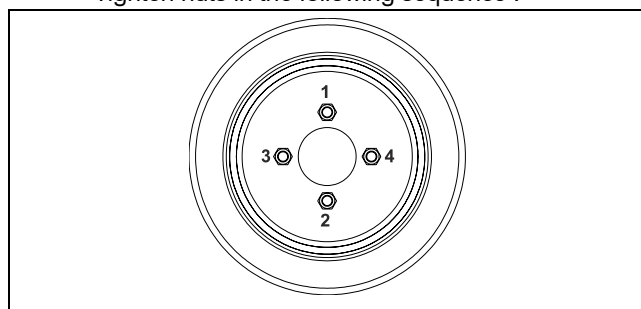

Torque value : 88 ft lb (119 N.m)

- Tightening of the nuts should be done in stages. Following the recommended sequence, tighten nuts as follow :

Torque Stages		
1st stage	2nd stage	3rd stage
30 ft lb	60 ft lb	88 ft lb
40 Nm	80 Nm	119 Nm

- Wheel nuts should be torqued after first 50 hours or after each wheel removal. Check and torque every 3 months or 150 hours of operation.

Rear Wheels :

- Coat the bolt with Loctite 222 over the whole thread.
- Tighten the bolt. Torque value : 16 ft lb (21 Nm)

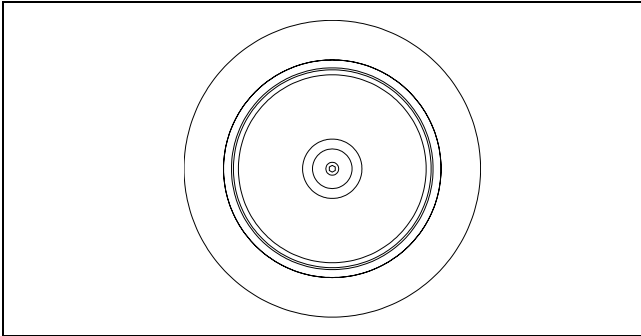

- Wheel bolt should be torqued after first 50 hours or after each wheel removal. Check and torque every 3 months or 150 hours of operation.

10. Verification of the Tilt Alarm Setting

Interval - Check after every 6 months of operation.

- Place machine on a known level surface.
- Position the selector switch to "Ground controls" and raise the mast by approximately 6" (15 cm)
- Chock both rear wheels.
- Position the selector switch to "Platform Controls".
- Place a spirit level (digital display) on the chassis positioned lengthways.
- With a jack of appropriate capacity, lift the front of the chassis and ensure :
 - An acoustic alarm sounds when the chassis is tilted at its max value (See Operation Specifications).
 - The corresponding LED lights up on the platform controls.
- Repeat steps (c) to (f) with the front wheels chocked and lift at the rear.
- Place a spirit level (digital display) across the chassis.
- With a jack of appropriate capacity, lift the right hand side of the chassis and ensure :
 - An acoustic alarm sounds when the chassis is tilted at its max value (see Operation Specifications).
 - The corresponding LED lights up on the platform controls
- Repeat steps (h) and (i) with the left hand side of the chassis lifted.
- Remove the blocks.

11. Wear Check of the Steering Brackets Thrust Washers

Check thickness of thrust washers on both steering brackets.

Replace the washers if their thickness is below 0.1" (2.5 mm).

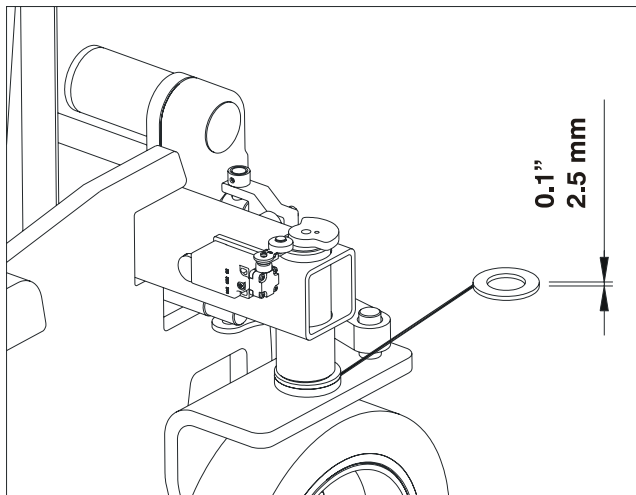

12. Wear Check of the Shelf Sliding Blocks

The sliding blocks (Qty 4), must be replaced if their height is below 0.8" (20 mm).

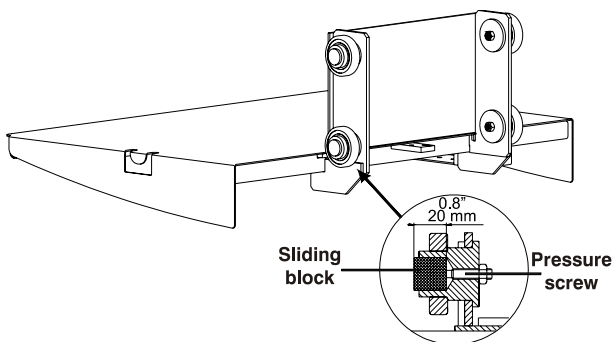

Check the condition of the pressure screw and of the bearing before installation. Replace the used parts by genuine parts.

After installation of the sliding blocks, perform a setting (alignment) of the shelf (refer to the Service manual).

CAUTION

THE PROFILED SECTIONS OF THE SHELF MUST BE CLEANED BEFORE BLOCKS REPLACEMENT. THE PROFILED SECTIONS OF THE SHELF MUST BE GREASED AFTER BLOCKS REPLACEMENT.

13. Wear Check of the Wheel Motor Brakes

NOTE: Before performing any maintenance on the brake, ensure the motor is not running and the brake is not powered. Disconnect the battery.

- The air gap (distance between the armature plate and the brake body) is 0.008" (0.2 mm).
- The gap cannot be adjusted. It is therefore necessary to periodically control the air gap and to replace the brake when it reaches 0.015" (0.4 mm).

DANGER

A BRAKE INCORRECTLY ADJUSTED CAN BE NOTICED BY A LONGER DISTANCE OR AN INCOMPLETE BRAKING FORCE.

14. Verification of the Lifting Chains

The service life of a lifting chain depends on the work platform operating conditions and on the environment in which the machine is used or stored. Service life is reduced if the chains are exposed to significant temperature fluctuations, acid or corrosive products or vapours, or abrasive dust.

Due to the high resistance level of their components, chains can be weakened through contact with a corrosive product.

Control of chain wear

Inspect thoroughly each chain in turn over its entire length :

- Chains, chain yokes, clevis pins and split pins must not be corroded.
- Plates must not be cracked.



- The plate clevis pins must not present excessive play. The pins must not be turned in their housing :

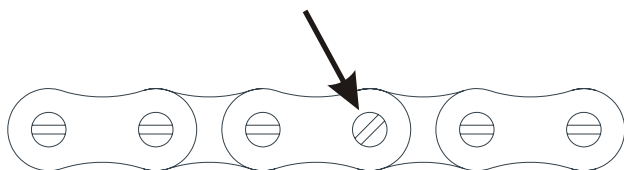

- Plates must not present a wear above 5% of the total height (refer to chart below) :

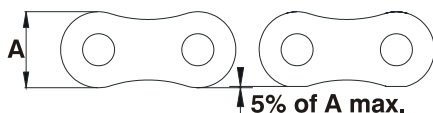

Pitch	5/8" 15,875 mm
A min.	0,45" 11,5 mm

- Chains stretching cannot be superior to the values indicated in the chart below :

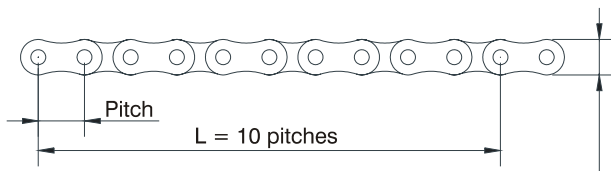

Pitch	5/8" (15,875 mm)
L max.	6' 1/2 (163,5 mm)

If a chain appears to be faulty or worn, both chains of the same stage must be replaced together; the condition of the pulleys and the telescopic mast alignment must be checked.



Corporate Office
JLG Industries, Inc.
1 JLG Drive
McConnellsburg PA. 17233-9533
USA
Phone: (717) 485-5161
Fax: (717) 485-6417

JLG Worldwide Locations

JLG Industries (Australia)
P.O. Box 5119
11 Bolwarra Road
Port Macquarie
N.S.W. 2444
Australia
Phone: (61) 2 65 811111
Fax: (61) 2 65 810122

JLG Latino Americana Ltda.
Rua Eng. Carlos Stevenson,
80-Suite 71
13092-310 Campinas-SP
Brazil
Phone: (55) 19 3295 0407
Fax: (55) 19 3295 1025

JLG Industries (UK) Ltd
Bentley House
Bentley Avenue
Middleton
Greater Manchester
M24 2GP
England
Phone: (44) 161 654 1000
Fax: (44) 161 654 1003

JLG France SAS
Z.I. de baulieu
47400 Fauillet
France
Phone: (33) 553 883 170
Fax: (33) 553 883 179

JLG Deutschland GmbH
Max Planck Strasse 21
D-27721 Ritterhude/Ihlpohl
Germany
Phone: (49) 421 69 350 - 20
Fax: (49) 421 69 350 - 45

JLG Equipment Services Ltd
Rm 1107 Landmark North
39 Lung Sum Avenue
Sheung Shui N.T.
Hong Kong
Phone: (852) 2639 5783
Fax: (852) 2639 5797

JLG Industries (Italia)
Via Po. 22
20010 Pregnana Milanese - MI
Italy
Phone: (39) 02 9359 5210
Fax: (39) 02 9359 5845

JLG Europe B.V.
Polaris Avenue 63
2132 HJ Foofddorp
The Netherlands
Phone: (31) 23 565 5665
Fax: (31) 23 557 2493

JLG Polska
Ul. Krolewska
00-060 Warszawa
Poland
Phone: (48) 91 4320 245
Fax: (48) 91 4358 200

JLG Industries (Scotland)
Wright Business Centre,
1 Lonmay Road
Queenslie
Glasgow G33 4EL
Scotland
Phone: (44) 141 781 6700
Fax: (44) 141 773 1907

Plataformas Elevadoras
JLG Iberica, S.L.
Trapadella, 2
P.I. Castellbisbal Sur
08755Castellbisbal
Spain
Phone: (34) 93 77 24700
Fax: (34) 93 77 11762

JLG Sverige AB
Enkopingsvagen 150
Box 704
SE - 176 27 Jarfalla
Sweden
Phone: (46) 8 506 59500
Fax: (46) 8 506 59534

www.jlg.com