



An Oshkosh Corporation Company

---

# ***Operation, Safety, and Maintenance Manual***

*Keep this manual with the machine at all times.*

***Model  
67SL***

**ANSI**



**P/N - 3121321**

*September 25, 2008*

---



## **FOREWORD**

This manual is a very important tool! Keep it with the machine at all times.

The purpose of this manual is to provide owners, users, operators, lessors, and lessees with the precautions and operating procedures essential for the safe and proper machine operation for its intended purpose.

Due to continuous product improvements, JLG Industries, Inc. reserves the right to make specification changes without prior notification. Contact JLG Industries, Inc. for updated information.

## SAFETY ALERT SYMBOLS AND SAFETY SIGNAL WORDS



This is the Safety Alert Symbol. It is used to alert you to the potential personal injury hazards. Obey all safety messages that follow this symbol to avoid possible injury or death

### **DANGER**

INDICATES AN IMMINENTLY HAZARDOUS SITUATION. IF NOT AVOIDED, WILL RESULT IN SERIOUS INJURY OR DEATH. THIS DECAL WILL HAVE A RED BACKGROUND.

### **WARNING**

INDICATES A POTENTIALITY HAZARDOUS SITUATION. IF NOT AVOIDED, COULD RESULT IN SERIOUS INJURY OR DEATH. THIS DECAL WILL HAVE AN ORANGE BACKGROUND.

### **CAUTION**

INDICATES A POTENTIALITY HAZARDOUS SITUATION. IF NOT AVOIDED, MAY RESULT IN MINOR OR MODERATE INJURY. IT MAY ALSO ALERT AGAINST UNSAFE PRACTICES. THIS DECAL WILL HAVE A YELLOW BACKGROUND.

**⚠ WARNING**

THIS PRODUCT MUST COMPLY WITH ALL SAFETY RELATED BULLETINS. CONTACT JLG INDUSTRIES, INC. OR THE LOCAL AUTHORIZED JLG REPRESENTATIVE FOR INFORMATION REGARDING SAFETY-RELATED BULLETINS WHICH MAY HAVE BEEN ISSUED FOR THIS PRODUCT.

**NOTICE**

JLG INDUSTRIES, INC. SENDS SAFETY RELATED BULLETINS TO THE OWNER OF RECORD OF THIS MACHINE. CONTACT JLG INDUSTRIES, INC. TO ENSURE THAT THE CURRENT OWNER RECORDS ARE UPDATED AND ACCURATE.

**NOTICE**

JLG INDUSTRIES, INC. MUST BE NOTIFIED IMMEDIATELY IN ALL INSTANCES WHERE JLG PRODUCTS HAVE BEEN INVOLVED IN AN ACCIDENT INVOLVING BODILY INJURY OR DEATH OF PERSONNEL OR WHEN SUBSTANTIAL DAMAGE HAS OCCURRED TO PERSONAL PROPERTY OR THE JLG PRODUCT.

**For:**

- Accident Reporting
- Product Safety Publications
- Current Owner Updates
- Questions Regarding Product Safety
- Standards and Regulations Compliance Information
- Questions Regarding Special Product Applications
- Questions Regarding Product Modifications

**Contact:**

Product Safety and Reliability Department  
JLG Industries, Inc.  
13224 Fountainhead Plaza  
Hagerstown, MD 21742

or Your Local JLG Office  
(See addresses on manual rear cover)

**In USA:**

Toll Free: 877-JLG-SAFE (877-554-7233)

**Outside USA:**

Phone: 240-420-2661  
E-mail: ProductSafety@JLG.com

## **REVISION LOG**

Original Issue	- September 28, 2006
Revised	- October 25, 2006
Revised	- December 21, 2006
Revised	- March 7, 2007
Revised	- March 28, 2007
Revised	- May 13, 2008
Revised	- September 25, 2008

<b>SECTION - PARAGRAPH, SUBJECT</b>	<b>PAGE</b>
<b>SECTION - 1 - SAFETY PRECAUTIONS</b>	
1.1 GENERAL.....	1-1
1.2 PRE-OPERATION.....	1-1
Operator Training and Knowledge.....	1-1
Workplace Inspection.....	1-2
Machine Inspection.....	1-3
1.3 OPERATION.....	1-3
General.....	1-3
Trip and Fall Hazards.....	1-4
Electrocution Hazards.....	1-5
Tipping Hazards.....	1-7
Crushing and Collision Hazards.....	1-8
1.4 TOWING, LIFTING, AND HAULING.....	1-9
1.5 MAINTENANCE.....	1-9
General.....	1-9
Maintenance Hazards.....	1-10
Battery Hazards.....	1-10
<b>SECTION - 2 - USER RESPONSIBILITIES, MACHINE PREPARATION AND INSPECTION</b>	
2.1 PERSONNEL TRAINING.....	2-1
Operator Training.....	2-1
Training Supervision.....	2-1

<b>SECTION - PARAGRAPH, SUBJECT</b>	<b>PAGE</b>
Operator Responsibility.....	2-1
2.2 PREPARATION, INSPECTION, AND MAINTENANCE.....	2-2
2.3 PRE-START INSPECTION.....	2-4
Function Check.....	2-5
Limit Switches.....	2-6
General.....	2-9
<b>SECTION - 3 - MACHINE CONTROLS</b>	
3.1 GENERAL.....	3-1
3.2 OPERATING CHARACTERISTICS AND LIMITATIONS.....	3-1
General.....	3-1
Placards.....	3-1
Capacities.....	3-2
3.3 CONTROLS AND INDICATORS.....	3-2
Ground Control Stations.....	3-2
Main Terminal Box.....	3-5
Ground Control Console.....	3-7
3.4 PLATFORM CONTROL CONSOLE.....	3-9
<b>SECTION - 4 - MACHINE OPERATION</b>	
4.1 DESCRIPTION.....	4-1

## TABLE OF CONTENTS

SECTION - PARAGRAPH, SUBJECT	PAGE	SECTION - PARAGRAPH, SUBJECT	PAGE
General Description of the Functions and Components . . . . .	4-1	Operator Unable to Control Machine . . . . .	5-2
4.2 STARTING . . . . .	4-1	Incident Notification . . . . .	5-2
4.3 LIFTING AND LOWERING . . . . .	4-2	5.3 MANUAL PROCEDURES . . . . .	5-3
4.4 AUTOMATIC SELF LEVELING CHASSIS . . . . .	4-3	Manual Platform Deck Retraction . . . . .	5-3
4.5 DRIVING THE MACHINE FROM THE PLATFORM . . . . .	4-4	Manual Platform Lowering (Prior to S/N 1200021189) . . . . .	5-5
4.6 STEERING . . . . .	4-6	Manual Platform Lowering (S/N 1200021189 to Present) . . . . .	5-6
4.7 HYDRAULIC PLATFORM EXTENSION . . . . .	4-6	5.4 EMERGENCY TOWING . . . . .	5-7
4.8 EMERGENCY LOWERING - MANUAL DESCENT . . . . .	4-6	Prior to Towing . . . . .	5-7
4.9 PARKING AND STOWING . . . . .	4-6		
4.10 TIE DOWN/LIFT LUGS . . . . .	4-7	<b>SECTION - 6 - GENERAL SPECIFICATIONS AND OPERATOR MAINTENANCE</b>	
Tie Down . . . . .	4-7	6.1 INTRODUCTION . . . . .	6-1
Lifting . . . . .	4-7	6.2 OPERATING SPECIFICATIONS . . . . .	6-2
4.11 TRANSPORT AND STORAGE OF THE MACHINE . . . . .	4-8	Dimensional Data . . . . .	6-3
		Capacities . . . . .	6-3
<b>SECTION - 5 - EMERGENCY PROCEDURES</b>		Tires . . . . .	6-3
5.1 GENERAL . . . . .	5-1	Engine . . . . .	6-4
Emergency Stop Switch . . . . .	5-1	Component Weights . . . . .	6-4
Platform Caught Overhead . . . . .	5-1	Lubrication . . . . .	6-7
Righting of Tipped Machine . . . . .	5-1	6.3 OPERATOR MAINTENANCE . . . . .	6-8
Post-Incident Inspection . . . . .	5-1	6.4 TIRES AND WHEELS . . . . .	6-13
5.2 EMERGENCY OPERATION . . . . .	5-2		

<b>SECTION - PARAGRAPH, SUBJECT</b>	<b>PAGE</b>
Tire Damage . . . . .	6-13
Tire Replacement . . . . .	6-13
Wheel Replacement . . . . .	6-14
Wheel Installation . . . . .	6-14

**SECTION - 7 - INSPECTION AND REPAIR LOG**

<b>SECTION - PARAGRAPH, SUBJECT</b>	<b>PAGE</b>
-------------------------------------	-------------

**List of Figures**

2-1. Limit Switch Locations . . . . .	2-7
2-2. Walk - Around Inspection Diagram. . . . .	2-8
2-3. Walk - Around Inspection Points (Sheet 1) . . . . .	2-9
2-4. Walk - Around Inspection Points (Sheet 2) . . . . .	2-10
3-1. Side Compartment Electrical Tray . . . . .	3-2
3-2. Engine Control . . . . .	3-3
3-3. Main Terminal Box . . . . .	3-5
3-4. Ground Control Console . . . . .	3-7
3-5. Platform Control Console . . . . .	3-9
3-6. Decal Location (ANSI) - Sheet 1 of 2 . . . . .	3-12
3-7. Decal Location (ANSI) - Sheet 2 of 2 . . . . .	3-13
3-8. Decal Location (CSA) - Sheet 1 of 2. . . . .	3-14
3-9. Decal Location (CSA) - Sheet 2 of 2. . . . .	3-15
4-1. Grade and Sideslope . . . . .	4-5
4-2. Lifting and Tie Down Points . . . . .	4-7
5-1. Drive Disconnect Hub. . . . .	5-8
6-1. Engine Operating Temperature Specifications - Sheet 1 of 2 . . . . .	6-5
6-2. Engine Operating Temperature Specifications - Sheet 2 of 2 . . . . .	6-6
6-3. Operator Maintenance and Lubrication Diagram. . .	6-8

# TABLE OF CONTENTS

---

SECTION - PARAGRAPH, SUBJECT	PAGE	SECTION - PARAGRAPH, SUBJECT	PAGE
<b>List of Tables</b>			
1-1	Minimum Approach Distances (M.A.D.) . . . . .	1-6	
2-1	Inspection and Maintenance Table . . . . .	2-3	
2-2	Cutout Switch Limits . . . . .	2-6	
3-1	Decal Legend . . . . .	3-16	
6-1	Operating Specifications . . . . .	6-2	
6-2	Dimensional Data . . . . .	6-3	
6-3	Capacities . . . . .	6-3	
6-4	Tire Specifications . . . . .	6-3	
6-5	Engine Specifications . . . . .	6-4	
6-6	Engine Battery Specifications . . . . .	6-4	
6-7	Component Weights . . . . .	6-4	
6-8	Hydraulic Oil . . . . .	6-7	
6-9	Lubrication Specifications . . . . .	6-7	
7-1	Inspection and Repair Log . . . . .	7-1	

## SECTION 1. SAFETY PRECAUTIONS

### 1.1 GENERAL

This section outlines the necessary precautions for proper and safe machine usage and maintenance. In order to promote proper machine usage, it is mandatory that a daily routine is established based on the content of this manual. A maintenance program, using the information provided in this manual and the Service and Maintenance Manual, must also be established by a qualified person and must be followed to ensure that the machine is safe to operate.

The owner/user/operator/lessor/lessee of the machine should not accept operating responsibility until this manual has been read, training is accomplished, and operation of the machine has been completed under the supervision of an experienced and qualified operator.

These sections contain the responsibilities of the owner, user, operator, lessor, and lessee concerning safety, training, inspection, maintenance, application, and operation. If there are any questions with regard to safety, training, inspection, maintenance, application, and operation, please contact JLG Industries, Inc. ("JLG").

### WARNING

FAILURE TO COMPLY WITH THE SAFETY PRECAUTIONS LISTED IN THIS MANUAL COULD RESULT IN MACHINE DAMAGE, PROPERTY DAMAGE, PERSONAL INJURY OR DEATH.

### 1.2 PRE-OPERATION

#### Operator Training and Knowledge

- The Operators and Safety Manual must be read in its entirety before operating the machine. For clarification, questions, or additional information regarding any portions of this manual, contact JLG Industries, Inc.

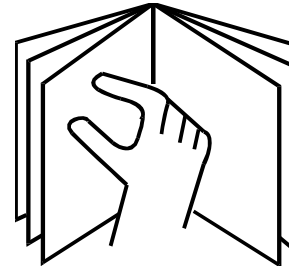

## **SECTION 1 - SAFETY PRECAUTIONS**

---

- An operator must not accept operating responsibilities until adequate training has been given by competent and authorized persons.
- Allow only those authorized and qualified personnel to operate the machine who have demonstrated that they understand the safe and proper operation and maintenance of the unit.
- Read, understand, and obey all DANGERS, WARNINGS, CAUTIONS, and operating instructions on the machine and in this manual.
- Ensure that the machine is to be used in a manner which is within the scope of its intended application as determined by JLG.
- All operating personnel must be familiar with the emergency controls and emergency operation of the machine as specified in this manual.
- Read, understand, and obey all applicable employer, local, and governmental regulations as they pertain to your utilization and application of the machine.
- Do not operate or raise the platform from a position on trucks, trailers, railway cars, floating vessels, scaffolds or other equipment unless the application is approved in writing by JLG.
- Before operation, check work area for overhead hazards such as electric lines, bridge cranes, and other potential overhead obstructions.
- Check floor surfaces for holes, bumps, drop-offs, obstructions, debris, concealed holes, and other potential hazards.
- Check the work area for hazardous locations. Do not operate the machine in hazardous environments unless approved for that purpose by JLG.
- Ensure that the ground conditions are adequate to support the maximum tire load indicated on the tire load decals located on the chassis adjacent to each wheel.
- Do not operate the machine when wind conditions exceed 28 mph (12.5 m/s).
- This machine can be operated in nominal ambient temperatures of 5°F to 113°F (-15°C to 45°C). Consult JLG to optimize operation outside of this temperature range.

### **Workplace Inspection**

- Precautions to avoid all hazards in the work area must be taken by the user before operation of the machine.

### Machine Inspection

- Do not operate this machine until the inspections and functional checks have been performed as specified in Section 2 of this manual.
- Do not operate this machine until it has been serviced and maintained according to the maintenance and inspection requirements as specified in the machine's Service and Maintenance Manual.
- Ensure all safety devices are operating properly. Modification of these devices is a safety violation.

#### **WARNING**

#### **MODIFICATION OR ALTERATION OF AN AERIAL WORK PLATFORM SHALL BE MADE ONLY WITH PRIOR WRITTEN PERMISSION FROM THE MANUFACTURER**

- Do not operate any machine on which the safety or instruction placards or decals are missing or illegible.
- Check the machine for modifications to original components. Ensure that any modifications have been approved by JLG.
- Avoid accumulation of debris on platform deck. Keep mud, oil, grease, and other slippery substances from footwear and platform deck.

### 1.3 OPERATION

#### General

- Do not use the machine for any purpose other than positioning personnel, their tools, and equipment.
- Before operation, the user must be familiar with the machine capabilities and operating characteristics of all functions.
- Never operate a malfunctioning machine. If a malfunction occurs, shut down the machine. Remove the unit from service and notify the proper authorities.
- Do not remove, modify, or disable any safety devices.
- Never slam a control switch or lever through neutral to an opposite direction. Always return switch to neutral and stop before moving the switch to the next function. Operate controls with slow and even pressure.
- Do not allow personnel to tamper with or operate the machine from the ground with personnel in the platform, except in an emergency.
- Do not carry materials directly on platform railing unless approved by JLG.
- When two or more persons are in the platform, the operator shall be responsible for all machine operations.

## SECTION 1 - SAFETY PRECAUTIONS

---

- Always ensure that power tools are properly stowed and never left hanging by their cord from the platform work area.
- Do not assist a stuck or disabled machine by pushing or pulling except by pulling at the chassis tie-down lugs.
- Stow scissor arm assembly and shut off all power before leaving machine.

### Trip and Fall Hazards

- JLG Industries, Inc. recommends that all persons in the platform wear a full body harness with a lanyard attached to an authorized lanyard anchorage point while operating this machine. For further information regarding fall protection requirements on JLG products, contact JLG Industries, Inc.

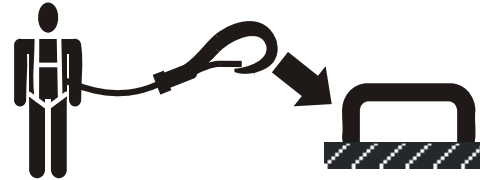

- Prior to operation, ensure all gates and rails are fastened and secured in their proper position. Identify the designated lanyard anchorage point(s) at the platform and securely attach the lanyard. Attach only one (1) lanyard per lanyard anchorage point

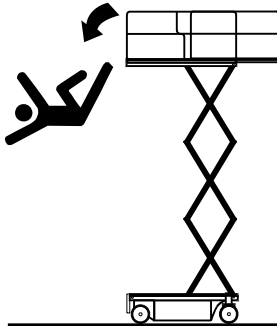

- Keep both feet firmly positioned on the platform floor at all times. Never position ladders, boxes, steps, planks, or similar items on unit to provide additional reach for any purpose.
- Never use the scissor arm assembly to gain access to or leave the platform.
- Use extreme caution when entering or leaving platform. Ensure that the scissor arm assembly is fully lowered. Face the machine when entering or leaving the platform. Always maintain “three point contact” with the machine, using two hands and one foot or two feet and one hand at all times during entry and exit.
- Keep oil, mud, and slippery substances cleaned from footwear and the platform floor.

### Electrocution Hazards

- This machine is not insulated and does not provide protection from contact or proximity to electrical current.

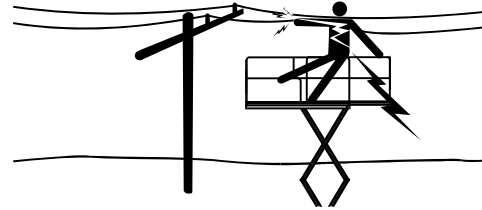

## SECTION 1 - SAFETY PRECAUTIONS

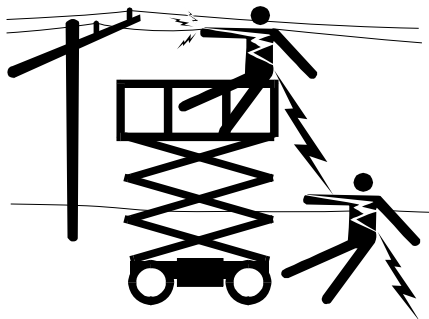

- Maintain safe clearance from electrical lines, apparatus, or any energized (exposed or insulated) parts in accordance with the Minimum Approach Distance (MAD) as specified in Table 1-1.
- Allow for machine movement and electrical line swaying.

**Table 1-1. Minimum Approach Distances (M.A.D.)**

Voltage Range (Phase to Phase)	MINIMUM APPROACH DISTANCE in Feet (Meters)
0 to 50KV	10 (3)
Over 50 KV to 200 KV	15 (5)
Over 200KV to 350 KV	20 (6)
Over 350 KV to 500 KV	25 (8)
Over 500 KV to 750 KV	35 (11)
Over 750 KV to 1000 KV	45 (14)

**NOTE:** *This requirement shall apply except where employer, local or governmental regulations are more stringent.*

- Maintain a clearance of at least 10 ft (3 m) between any part of the machine and its occupants, their tools, and their equipment from any electrical line or apparatus carrying up to 50,000 volts. One foot additional clearance is required for every additional 30,000 volts or less.
- The minimum approach distance may be reduced if insulating barriers are installed to prevent contact, and the barriers are rated for the voltage of the line being guarded. These barriers shall not be part of (or attached to) the machine. The minimum approach distance shall be

reduced to a distance within the designed working dimensions of the insulating barrier. This determination shall be made by a qualified person in accordance with the employer, local, or governmental requirements for work practices near energized equipment.

### **⚠ DANGER**

**DO NOT MANEUVER MACHINE OR PERSONNEL INSIDE PROHIBITED ZONE (MAD). ASSUME ALL ELECTRICAL PARTS AND WIRING ARE ENERGIZED UNLESS KNOWN OTHERWISE.**

### **Tippling Hazards**

- Ensure that the ground conditions are adequate to support the maximum tire load indicated on the tire load decals located on the chassis adjacent to each wheel. Do not travel on unsupported surfaces.
- The user should be familiar with the driving surface before driving. Do not exceed the allowable sideslope and grade while driving

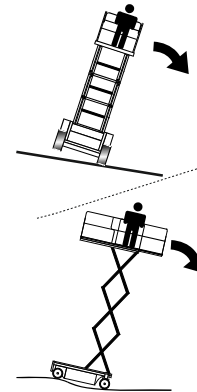

- Do not elevate platform or drive with platform elevated while on or near a sloping, uneven, or soft surface. Ensure machine is positioned on a firm, level and uniformly supported surface before elevating platform or driving with the platform in the elevated position.
- Before driving on floors, bridges, trucks, and other surfaces, check allowable capacity of the surfaces.
- Never exceed the maximum work load as specified on the platform. Keep all loads within the confines of the platform, unless authorized by JLG.

## SECTION 1 - SAFETY PRECAUTIONS

---

- Keep the chassis of the machine a minimum of 0.6 m (2 ft) from holes, bumps, drop-offs, obstructions, debris, concealed holes, and other potential hazards at the ground level.
- Never attempt to use the machine as a crane. Do not tie-off machine to any adjacent structure. Never attach wire, cable, or any similar items to platform.
- Do not operate the machine when wind conditions exceed the maximum allowable wind speed.
- Do not cover the platform sides or carry large surface-area items in the platform when operating outdoors. The addition of such items increases the exposed wind area of the machine.
- Do not increase the platform size with unauthorized deck extensions or attachments.
- If scissor arm assembly or platform is caught so that one or more wheels are off the ground, all persons must be removed before attempting to free the machine. Use cranes, forklift trucks, or other appropriate equipment to stabilize machine and remove personnel.

### Crushing and Collision Hazards

- Approved head gear must be worn by all operating and ground personnel.

- Keep hands and limbs out of the scissor arm assembly during operation.
- Watch for obstructions around machine and overhead when driving. Check clearances above, on sides, and bottom of platform when lifting or lowering platform.

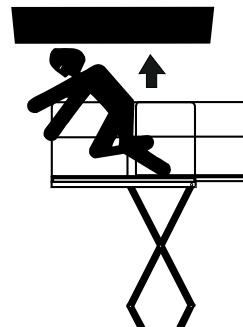

- During operation, keep all body parts inside platform railing.
- Always post a lookout when driving in areas where vision is obstructed.
- Keep non-operating personnel at least 6 ft (1.8 m) away from machine during all driving operations.
- Under all travel conditions, the operator must limit travel speed according to conditions of ground surface, congested areas, and other factors.

tion, visibility, slope, location of personnel, and other factors causing hazards of collision or injury to personnel.

- Be aware of stopping distances in all drive speeds. When driving in high speed, switch to low speed before stopping. Travel grades in low speed only.
- Do not use high speed drive in restricted or close quarters or when driving in reverse.
- Exercise extreme caution at all times to prevent obstacles from striking or interfering with operating controls and persons in the platform.
- Ensure that operators of other overhead and floor level machines are aware of the aerial work platform's presence. Disconnect power to overhead cranes. Barricade floor area if necessary.
- Avoid operating over ground personnel. Warn personnel not to work, stand, or walk under a raised platform. Position barricades on floor as necessary.

### 1.4 TOWING, LIFTING, AND HAULING

- Never allow personnel in platform while towing, lifting, or hauling.
- This machine should not be towed, except in the event of emergency, malfunction, power failure, or loading/unloading. Refer to emergency towing procedures.
- Ensure platform is fully retracted and completely empty of tools prior to towing, lifting or hauling.
- Refer to Section 4 for lifting information.

### 1.5 MAINTENANCE

#### General

This section contains general safety precautions which must be observed during maintenance of this machine. Additional precautions to be observed during machine maintenance are inserted at the appropriate points in this manual and in the Service and Maintenance Manual. It is of utmost importance that maintenance personnel pay strict attention to these precautions to avoid possible injury to personnel or damage to the machine or property. A maintenance program must be established by a qualified person and must be followed to ensure that the machine is safe.

## SECTION 1 - SAFETY PRECAUTIONS

---

### Maintenance Hazards

- Shut off power to all controls and ensure that all operating systems are secured from inadvertent motion prior to performing any adjustments or repairs.
- Never work under an elevated platform until it has been fully lowered to the full down position, if possible, or otherwise supported and restrained from movement with appropriate safety props, blocking, or overhead supports.
- Always relieve hydraulic pressure from all hydraulic circuits before loosening or removing hydraulic components.
- Always disconnect batteries when servicing electrical components or when performing welding on the machine.
- Shut down the engine (if equipped) while fuel tanks are being filled.
- Ensure replacement parts or components are identical or equivalent to original parts or components.
- Never attempt to move heavy parts without the aid of a mechanical device. Do not allow heavy objects to rest in an unstable position. Ensure adequate support is provided when raising components of the machine.
- Remove all rings, watches, and jewelry when performing any maintenance. Do not wear loose fitting clothing or

long hair unrestrained which may become caught or entangled in equipment.

- Use only clean approved non-flammable cleaning solvents.
- Never alter, remove, or substitute any items such as counterweights, tires, batteries, platforms or other items that may reduce or affect the overall weight or stability of the machine.
- Reference the Service and Maintenance Manual for the weights of critical stability items.

### **WARNING**

**MODIFICATION OR ALTERATION OF AN AERIAL WORK PLATFORM SHALL BE MADE ONLY WITH PRIOR WRITTEN PERMISSION FROM THE MANUFACTURER.**

### Battery Hazards

- Always disconnect batteries when servicing electrical components or when performing welding on the machine.
- Do not allow smoking, open flame, or sparks near battery during charging or servicing.
- Do not contact tools or other metal objects across the battery terminals.

- Always wear hand, eye, and face protection when servicing batteries. Ensure that battery acid does not come in contact with skin or clothing.

 **WARNING**

**BATTERY FLUID IS HIGHLY CORROSIVE. AVOID CONTACT WITH SKIN AND CLOTHING AT ALL TIMES. IMMEDIATELY RINSE ANY CONTACTED AREA WITH CLEAN WATER AND SEEK MEDICAL ATTENTION.**

- Charge batteries only in a well ventilated area.
- Avoid overfilling the battery fluid level. Add distilled water to batteries only after the batteries are fully charged.



## **SECTION 2. USER RESPONSIBILITIES, MACHINE PREPARATION AND INSPECTION**

### **2.1 PERSONNEL TRAINING**

The aerial platform is a personnel handling device; so it is necessary that it be operated and maintained only by trained personnel.

Persons under the influence of drugs or alcohol or who are subject to seizures, dizziness or loss of physical control must not operate this machine.

#### **Operator Training**

Operator training must cover:

1. Use and limitations of the controls in the platform and at the ground, emergency controls and safety systems.
2. Control labels, instructions, and warnings on the machine.
3. Rules of the employer and government regulations.
4. Use of approved fall protection equipment.
5. Enough knowledge of the mechanical operation of the machine to recognize a malfunction or potential malfunction.

6. The safest means to operate the machine where overhead obstructions, other moving equipment, and obstacles, depressions, holes, drop-offs.
7. Means to avoid the hazards of unprotected electrical conductors.
8. Specific job requirements or machine application.

#### **Training Supervision**

Training must be done under the supervision of a qualified person in an open area free of obstructions until the trainee has developed the ability to safely control and operate the machine.

#### **Operator Responsibility**

The operator must be instructed that he/she has the responsibility and authority to shut down the machine in case of a malfunction or other unsafe condition of either the machine or the job site.

## **2.2 PREPARATION, INSPECTION, AND MAINTENANCE**

The following table covers the periodic machine inspections and maintenance recommended by JLG Industries, Inc. Consult local regulations for further requirements for aerial work platforms. The frequency of inspections and maintenance must be increased as necessary when the machine is used in a harsh or hostile environment, if the machine is used with increased frequency, or if the machine is used in a severe manner.

### **NOTICE**

**JLG INDUSTRIES, INC. RECOGNIZES A FACTORY-CERTIFIED SERVICE TECHNICIAN AS A PERSON WHO HAS SUCCESSFULLY COMPLETED THE JLG SERVICE TRAINING SCHOOL FOR THE SPECIFIC JLG PRODUCT MODEL.**

## SECTION 2 - USER RESPONSIBILITIES, MACHINE PREPARATION AND INSPECTION

**Table 2-1. Inspection and Maintenance Table**

Type	Frequency	Primary Responsibility	Service Qualification	Reference
Pre-Start Inspection	Before using each day; or whenever there's an Operator change.	User or Operator	User or Operator	Operator and Safety Manual
Pre-Delivery Inspection (See Note)	Before each sale, lease, or rental delivery.	Owner, Dealer, or User	Qualified JLG Mechanic	Service and Maintenance Manual and applicable JLG inspection form
Frequent Inspection (See Note)	In service for 3 months or 150 hours, whichever comes first; or  Out of service for a period of more than 3 months; or  Purchased used.	Owner, Dealer, or User	Qualified JLG Mechanic	Service and Maintenance Manual and applicable JLG inspection form
Annual Machine Inspection (See Note)	Annually, no later than 13 months from the date of prior inspection.	Owner, Dealer, or User	Factory Certified Service Technician (Recommended)	Service and Maintenance Manual and applicable JLG inspection form
Preventative Maintenance	At intervals as specified in the Service and Maintenance Manual.	Owner, Dealer, or User	Qualified JLG Mechanic	Service and Maintenance Manual

**NOTE:** Inspection forms are available from JLG. Use the Service and Maintenance Manual to perform inspections.

## SECTION 2 - USER RESPONSIBILITIES, MACHINE PREPARATION AND INSPECTION

### 2.3 PRE-START INSPECTION

The Pre-Start Inspection should include each of the following:

1. **Cleanliness** – Check all surfaces for leakage (oil, fuel, or battery fluid) or foreign objects. Report any leakage to the proper maintenance personnel.
2. **Structure** - Inspect the machine structure for dents, damage, weld or parent metal cracks or other discrepancies.

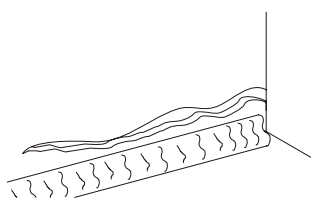

Parent Metal Crack

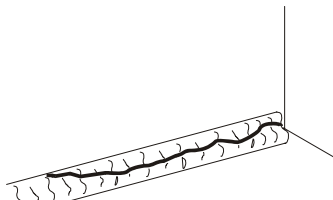

Weld Crack

3. **Decals and Placards** – Check all for cleanliness and legibility. Make sure none of the decals and placards are missing. Make sure all illegible decals and placards are cleaned or replaced.

4. **Operators and Safety Manuals** – Make sure a copy of the Operator and Safety Manual is enclosed in the weather resistant storage container.
5. **“Walk-Around” Inspection** – Refer to Figure 2-2., Walk - Around Inspection Diagram.
6. **Battery** – Charge as required.
7. **Fuel** - (Combustion Engine Powered Machines) – Add the proper fuel as necessary.
8. **Engine Oil Supply** - Ensure that the engine oil level is at the full mark on the dipstick and the filler cap is secure
9. **Fluid Levels** - Be sure to check the engine oil and the hydraulic oil levels.
10. **Accessories/Attachments** - Reference the Operator and Safety Manual of each attachment or accessory installed upon the machine for specific inspection, operation, and maintenance instructions.
11. **Function Check** – Once the “Walk-Around” Inspection is complete, perform a functional check of all systems in an area free of overhead and ground level obstructions. Refer to Section 4 for more specific instructions on the operation of each function.

### **WARNING**

**IF THE MACHINE DOES NOT OPERATE PROPERLY, TURN OFF THE MACHINE IMMEDIATELY! REPORT THE PROBLEM TO THE PROPER MAINTENANCE PERSONNEL. DO NOT OPERATE THE MACHINE UNTIL IT IS DECLARED SAFE FOR OPERATION.**

### **Function Check**

Perform the Function Check as follows:

1. From the ground control panel with no load in the platform:
  - a. Check that all function control switches and locks are in place.
  - b. Operate all functions and check all limiting and cut-out switches (see Table 2-2, Cutout Switch Limits).
  - c. Check for proper lifting and lowering of the platform.
  - d. If the platform extension is extended, check that the extension retracts.

**NOTE:** *Be sure the platform extension is retracted before lowering.*

- e. Ensure that all machine functions are disabled when the Emergency Stop Button is activated.

- f. Check manual descent.
  - g. Check for proper lifting and lowering of the platform.
2. From the platform control console:
    - a. Ensure that the control console is firmly secured in the proper location.
    - b. Check that all guards protecting the switches locks are in place.
    - c. Operate all functions.
    - d. Ensure that all machine functions are disabled when the Emergency Stop Button is pushed in.
    - e. Ensure that all LED's in the control box are working properly.
    - f. Check that the platform extension extends and retracts properly.
    - g. With the platform in the transport (stowed) position and with outriggers not selected:
      - i. Drive the machine on a level grade and stop to ensure the brakes hold
      - ii. To ensure proper operation of the tilt sensor, drive the machine onto a tilt greater than the preset 3° and attempt to lift.

## SECTION 2 - USER RESPONSIBILITIES, MACHINE PREPARATION AND INSPECTION

### Limit Switches

Check that the following limit switches function properly by attempting to exceed the preset limits.

1. Lowered Position Limit Switch - Outriggers cannot be deployed beyond the height of 9.8 ft (3 m).
2. Limit Switches for Drive Mode:
  - a. High Drive Speed Limit Switch - High drive speed is possible up to a platform height of 11.5 ft (3.5 m). Once the platform exceeds this limit, only low drive speed is possible.
  - b. Maximum Drive Height/Maximum Height without Outriggers Limit Switch - The maximum allowable drive height is 50 ft (15.2 m). The lifting function, without outriggers deployed, is only permitted up to a platform height of 50 ft (15.2 m) as well.
3. Tilt Switch - If the machine is exceeding a tilt angle of 3°, the platform cannot be elevated beyond 11.5 ft (3.5 m), or if driving while elevated, the drive function will be cut out.
4. Maximum Height Switch - The Maximum Height Switch cuts out the lift function once the platform reaches 66.6 ft (20.3 m). This maximum height is only achieved when the outriggers are selected and deployed.

5. Outrigger Interlocks - These switches allow the machine to be driven when all outriggers are completely retracted. The switch also prevents the platform from being raised until the machine is level.

**Table 2-2. Cutout Switch Limits**

Limit and Cutout Switch	Limit
Lowered Position	9.8 ft (3 m)
High Drive Speed Cutout *	11.5 ft (3.5 m)
Maximum Drive Height/Maximum Height without Outriggers*	50 ft (15.3 m)
Tilt *	3°
Maximum Height *	66.6 ft (20.3 m)
Outrigger Interlock	drive cut out when outriggers activated; lift cut out when not level

**NOTE:** \* - these limit switches have corresponding LED's on the platform control console (refer to Figure 3-5., Platform Control Console). See page 3-9 and 3-10 for LED functionality.

## SECTION 2 - USER RESPONSIBILITIES, MACHINE PREPARATION AND INSPECTION

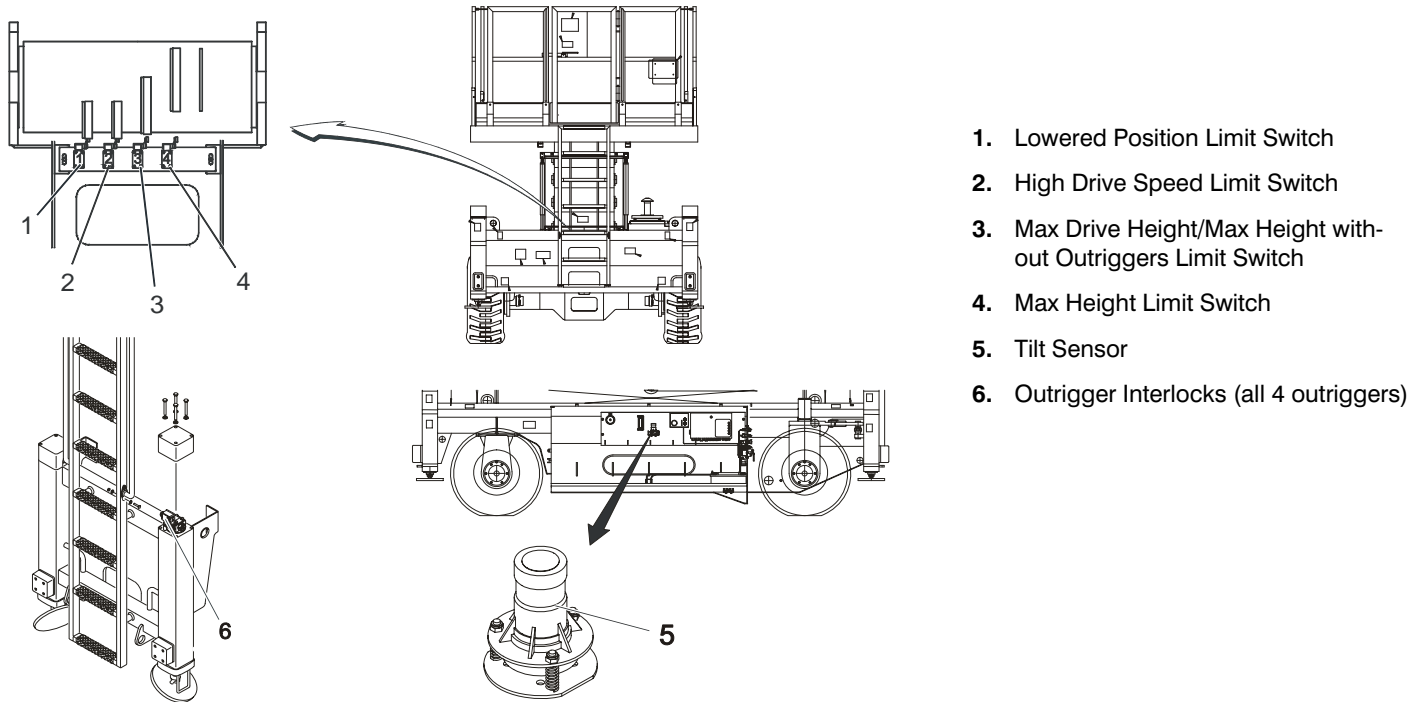

Figure 2-1. Limit Switch Locations

## SECTION 2 - USER RESPONSIBILITIES, MACHINE PREPARATION AND INSPECTION

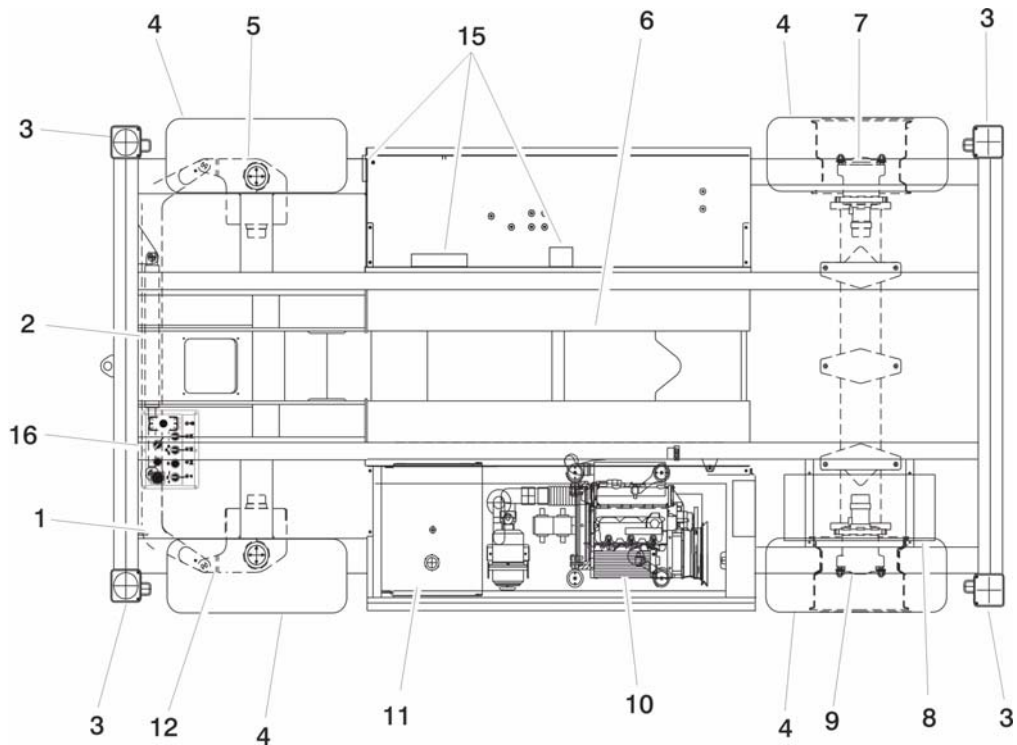

Figure 2-2. Walk - Around Inspection Diagram

## SECTION 2 - USER RESPONSIBILITIES, MACHINE PREPARATION AND INSPECTION

### General

Begin the “Walk-Around Inspection” at Item 1, as noted on the diagram. Continue to the right (counterclockwise viewed from top) checking each item in sequence for the conditions listed in the “Walk-Around Inspection Checklist.”

#### **⚠ WARNING**

**TO AVOID POSSIBLE INJURY, BE SURE MACHINE POWER IS “OFF” DURING “WALK-AROUND INSPECTION.”**

#### **NOTICE**

**DO NOT OVERLOOK VISUAL INSPECTION OF CHASSIS UNDERSIDE. CHECKING THIS AREA OFTEN RESULTS IN DISCOVERY OF CONDITIONS WHICH COULD CAUSE EXTENSIVE MACHINE DAMAGE.**

**NOTE:** *On each item, make sure there are no loose or missing parts, that they are securely fastened, and that no visible damage exists in addition to any other criteria mentioned.*

1. Steer Linkage - See Note.
2. Steer Cylinder - See Note

3. Outrigger - (right front) - See Note
4. Wheel and Tire Assembly - Properly secured, no missing lug nuts. Refer to Section 6. Inspect wheels for damage and corrosion.
5. Tie Rod and Spindle - (right front) - See Note
6. Lift Cylinder - See Note
7. Drive Hub, Right Rear - See Note
8. Fuel Tank - See Note
9. Drive Hub, Left Rear - See Note
10. Motor and Hydraulic Pump Assembly - Check engine oil level. See Note
11. Hydraulic Reservoir - Recommended hydraulic fluid level on level indicator on tank. Breather cap secure and working.
12. Tie Rod and Spindle - (left front) - See Note
13. Scissor Arms and Sliding Wear Pads (Not Shown) - See Note

**Figure 2-3. Walk - Around Inspection Points (Sheet 1)**

## **SECTION 2 - USER RESPONSIBILITIES, MACHINE PREPARATION AND INSPECTION**

---

- 14. Control Valve - (Not Shown) No unsupported wires or hoses; no damaged or broken wires.
- 15. Ground Controls - Placard secure and legible, control switches return to neutral position, emergency stop switch functions properly.
- 16. Platform Control Console - Placard secure and legible, control lever and switches return to neutral, trigger switch and emergency stop switch function properly, operation and safety manual in storage box.
- 17. Platform/Handrail Installation (Not Shown) - See Note

**Figure 2-4. Walk - Around Inspection Points (Sheet 2)**

## **SECTION 3. MACHINE CONTROLS**

### **3.1 GENERAL**

#### **NOTICE**

**SINCE THE MANUFACTURER HAS NO DIRECT CONTROL OVER MACHINE APPLICATION AND OPERATION, CONFORMANCE WITH GOOD SAFETY PRACTICES IN THESE AREAS IT IS THE RESPONSIBILITY OF THE USER AND HIS OPERATING PERSONNEL.**

This section provides the necessary information needed to understand control functions. Included in this section are the operating characteristics and limitations, and functions and purposes of controls and indicators. It is important that the user read and understand the proper procedures before operating the machine. These procedures will aid in obtaining optimum service life and safe operation.

### **3.2 OPERATING CHARACTERISTICS AND LIMITATIONS**

#### **General**

A thorough knowledge of the operating characteristics and limitations of the machine is always the first requirement for any user, regardless of user's experience with similar types of equipment.

#### **Placards**

Important points to remember during operation are provided at the control stations by DANGER, WARNING, CAUTION, IMPORTANT and INSTRUCTION placards. This information is placed at various locations for the express purpose of alerting personnel of potential hazards constituted by the operating characteristics and load limitations of the machine. See foreword for definitions of the above placards.

### Capacities

Raising platform above the stowed position with or without any load in platform, is based on the following criteria:

1. Machine is level and positioned on a firm supporting surface.
2. Load is within manufacturer's rated capacity.
3. All machine systems are functioning properly.

### 3.3 CONTROLS AND INDICATORS

#### Ground Control Stations

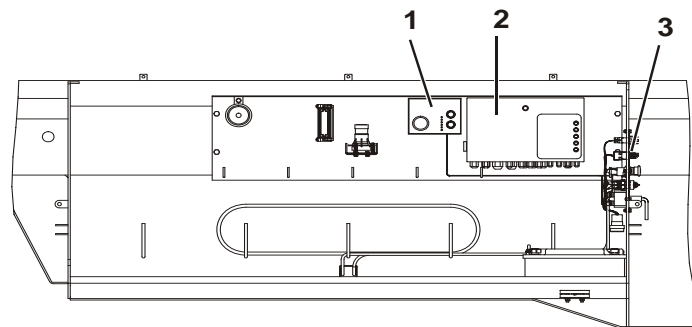

1. Engine Control
2. Main Terminal Box
3. Ground Control Console

**Figure 3-1. Side Compartment Electrical Tray**

**⚠ WARNING**

DO NOT OPERATE FROM GROUND CONTROL STATION WITH PERSONNEL IN THE PLATFORM EXCEPT IN AN EMERGENCY. PERFORM AS MANY PRE-OPERATIONAL CHECKS AND INSPECTIONS FROM THE GROUND CONTROL STATION AS POSSIBLE.

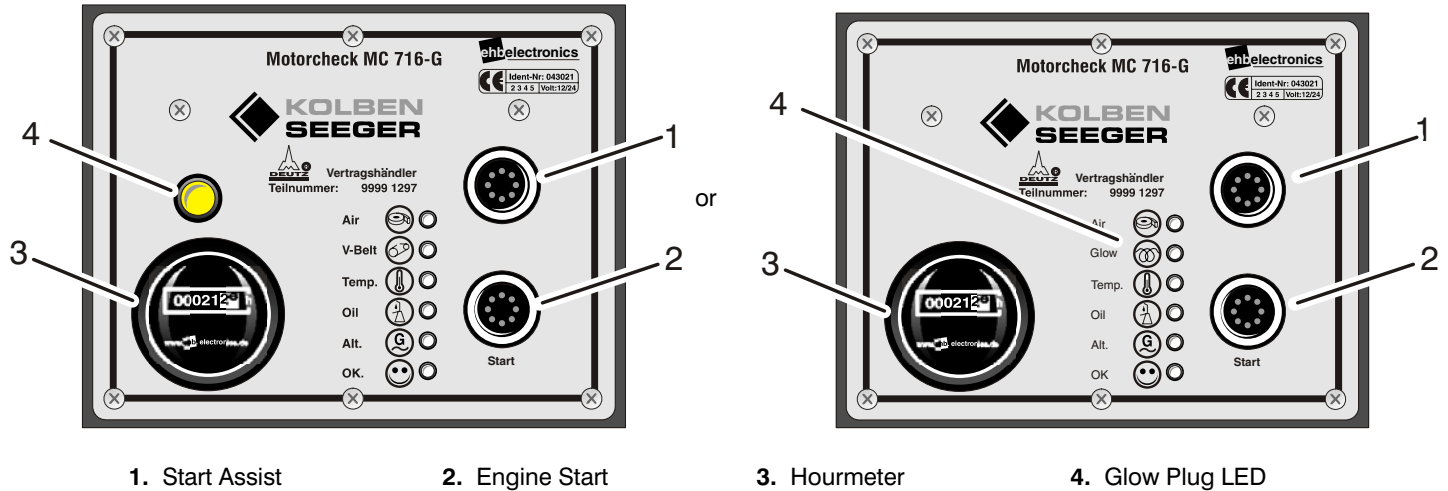

Figure 3-2. Engine Control

## **SECTION 3 - MACHINE CONTROLS**

---

1. Start Assist - This push button is used to help assist starting the machine in cold temperatures. (overrides 6 second crank limit of Engine Start Button)
2. Engine Start - A push button switch that, when depressed, will start the engine. (crank time limited to 6 seconds before power supply required recycling)
3. Hourmeter - A meter used to measure the amount of time the machine is in use.
4. Glow Plug LED - This Yellow LED is off under normal operating conditions. The LED is illuminated when the ignition is on and the temperature sensing requires pre-glow.

**NOTE:** *Do not start machine when Glow Plug LED is illuminated. Once the LED goes out, machine starting is permitted.*

## Main Terminal Box

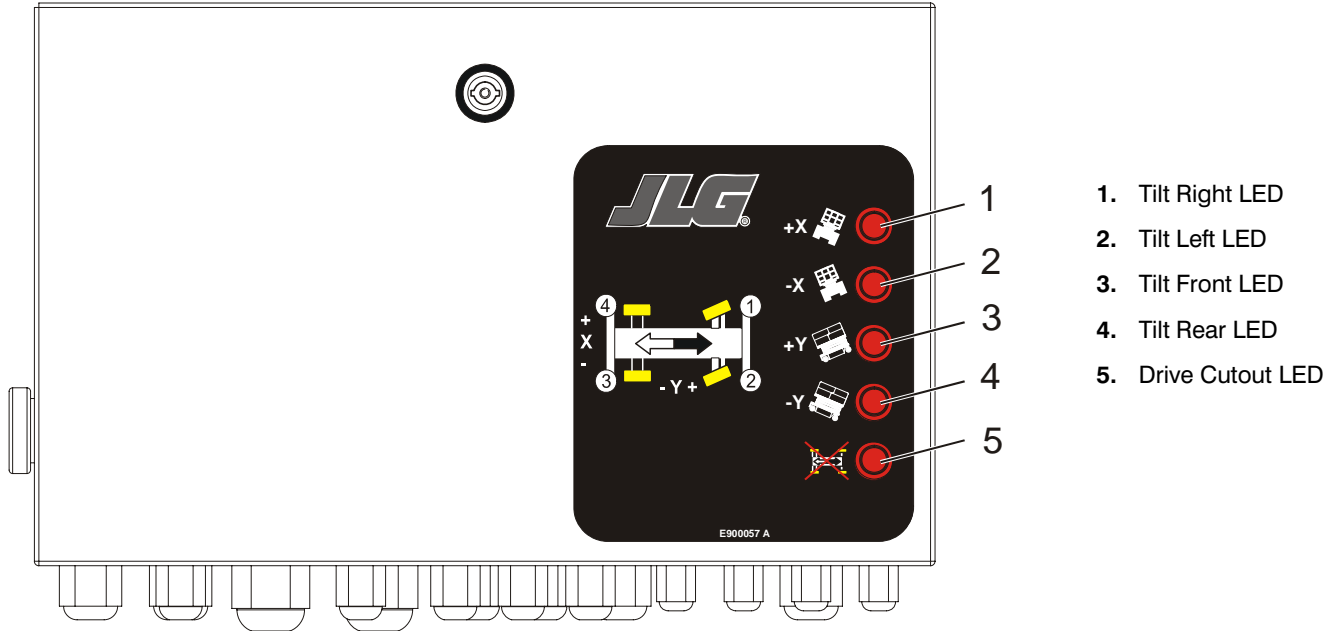

Figure 3-3. Main Terminal Box

## **SECTION 3 - MACHINE CONTROLS**

---

**NOTE:** *The following LED's are part of the self leveling system and illuminate as the machine self levels.*

1. Tilt Right LED - This LED will illuminate any time the machine is tilted to the right.
2. Tilt Left LED - This LED will illuminate any time the machine is tilted to the left.
3. Tilt Front LED - This LED will illuminate any time the machine is tilted toward the machine front.
4. Tilt Rear LED - This LED will illuminate any time the machine is tilted toward the machine rear.
5. Drive Cutout LED - This LED is illuminated when the outriggers are used and the lift function is operated.

## Ground Control Console

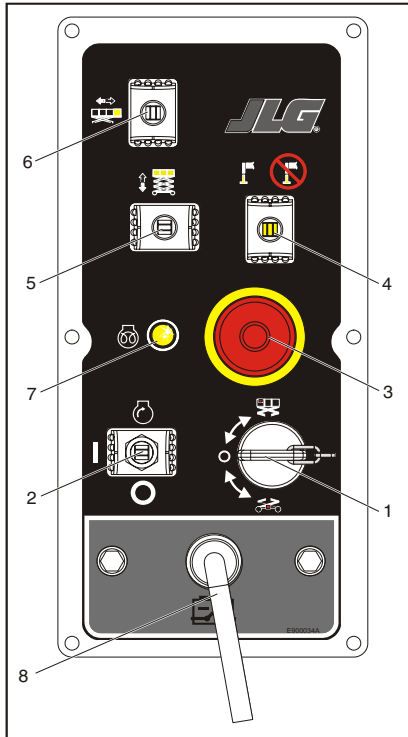

1. Platform/ Ground Select (Key Switch)
2. Engine Start Switch
3. Emergency Stop Button
4. Outrigger Select Switch
5. Platform Lift/Lower Switch
6. Deck Extend/Retract Switch
7. Glow Plug LED
8. Battery Disconnect Switch

Figure 3-4. Ground Control Console

## SECTION 3 - MACHINE CONTROLS

---

### Ground Control Descriptions:

1. Platform/Ground Select - This three way keyswitch is used to select between platform controls or ground controls. When in the center position, the machine is disabled.
2. Engine Start Switch - Toggle Switch used to start engine.
3. Emergency Stop Button - Button, when depressed, will immediately shut the machine off. Cuts out all functions except emergency platform lowering.
4. Outrigger Select Switch - Toggle Switch used to select if outriggers auto leveling function is active or not.
5. Platform Lift/Lower Switch - Toggle switch used to raise and lower platform.
6. Deck Extend/Retract Switch - Toggle switch used to extend and retract platform deck extension.

**NOTE:** *The platform deck extension should be retracted before lowering the platform.*

7. Glow Plug LED - This Yellow LED is off under normal operating conditions. The LED is illuminated when the ignition is on and the temperature sensing requires pre-glow.

**NOTE:** *Do not start machine when Glow Plug LED is illuminated. Once the LED goes out, machine starting is permitted.*

8. Battery Disconnect Switch - Disconnects ground control panel from the battery.

### 3.4 PLATFORM CONTROL CONSOLE

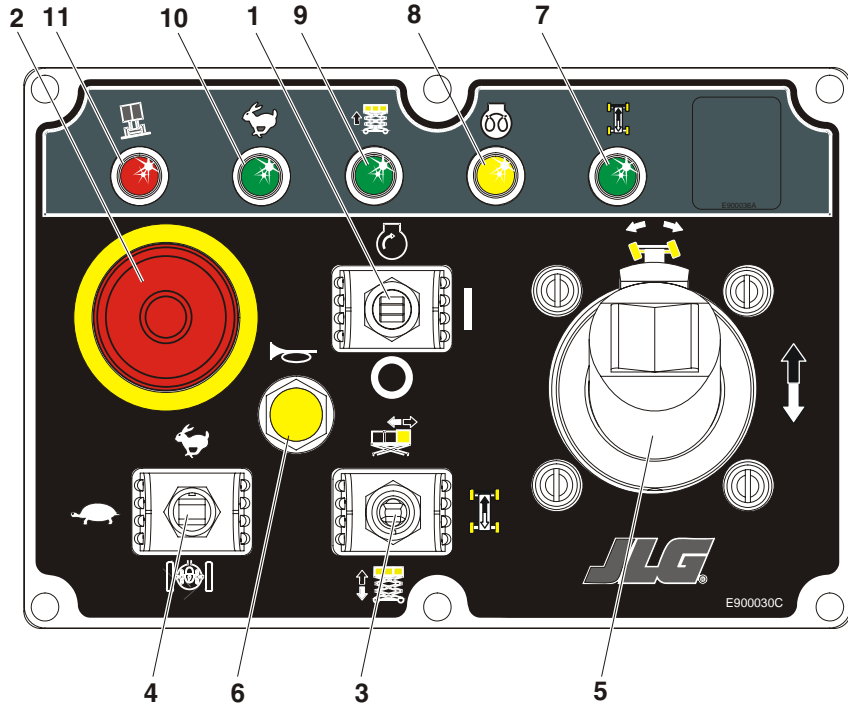

1. Engine Start Switch
2. Emergency Stop Button
3. Deck Extension/Drive/Lift Select Switch
4. Drive Speed Switch
5. Lift/Drive/Deck/Steer Controller
6. Horn Button
7. Drive Enabled LED
8. Glow Plug Active or Enabled LED
9. Lift Enabled LED
10. High Drive Speed Enabled LED
11. Tilt LED

Figure 3-5. Platform Control Console

## SECTION 3 - MACHINE CONTROLS

---

### Platform Control Descriptions:

When platform/ground control select switch is switched to platform all movements and operations are controlled via the platform control panel. The controls are activated through either push-buttons or toggle switches, whose functions are marked with symbols and / or written text.

1. Engine Start Switch - Toggle switch that turns the diesel engine on and off. Up for on, down for off.
2. Emergency Stop Button - Button, when depressed, will immediately shut the machine off. Cuts out all functions except emergency platform lowering.
3. Deck Extension/Drive/Lift Select Switch - 3 position toggle switch that selects the functions of platform extension, drive or lift. Up for platform extension, middle for drive, and down for lift. Works in conjunction with the joystick controller.
4. Drive Speed Switch - 3 position toggle switch that selects between fast drive, slow drive or posi-traction. Posi-traction evenly distributes the torque between all four wheels to provide better traction in situations that require it.
5. Lift/Drive/Deck/Steer Controller - The Controller works in conjunction with the platform extension, drive and the lift switch depending upon which function is selected. The button on the front of the joystick is the enable trigger. This trigger must be held in to work all joystick controlled functions. When the Drive function is selected, moving the joystick forward and backwards operates the forward and reverse movement of the machine. The switch on top of the joystick controls the steering of the machine when the Drive function is selected. When the Deck function is selected, moving the joystick forward and backward extends and retracts the platform deck extension. When the Lift function is selected, moving the joystick forward and backwards raises and lowers the platform.
6. Horn - Button, when depressed, activates the horn.
7. Drive Enabled LED - This Green LED is illuminated when drive is enabled. The LED goes out when the platform is above the maximum drive height, or with outriggers selected and deployed.
8. Glow Plug Enabled or Active LED - This Yellow LED is off under normal operating conditions. The LED is illuminated when the ignition is on and the temperature sensing requires pre-glow.

**NOTE:** *Do not start machine when Glow Plug LED is illuminated. Once the LED goes out, machine starting is permitted.*

9. Lift Enabled LED - This Green LED is illuminated when the lift function is enabled. The light goes out when tilted above 11.5 ft (3.5 m) or at maximum height 66.7 ft (20.3 m) with the outriggers deployed, or 50 ft (15.3 m) with the outriggers not deployed.
10. High Drive Speed Enabled LED - This Green LED is illuminated when high drive speed is enabled. The light goes out when the platform is above the high drive speed limit.
11. Tilt (slope) LED - This Red LED will illuminate when the machine is driven on a slope greater than the allowable 3°. The LED remains off under normal operating conditions.

## SECTION 3 - MACHINE CONTROLS

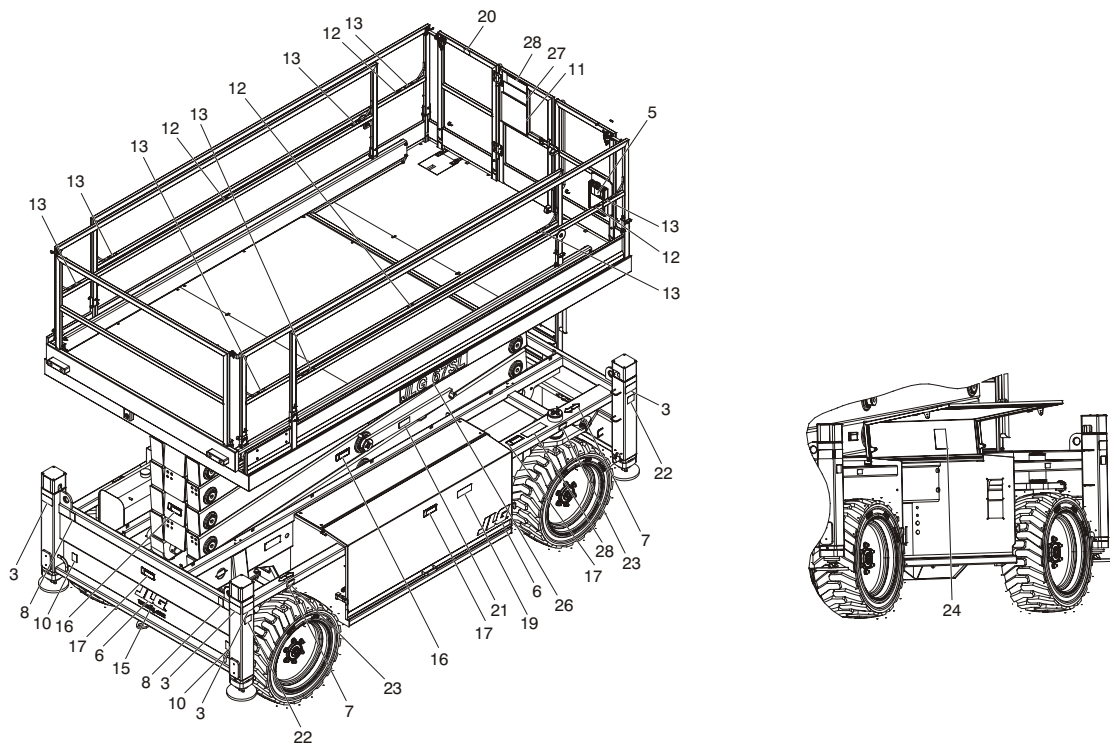

Figure 3-6. Decal Location (ANSI) - Sheet 1 of 2

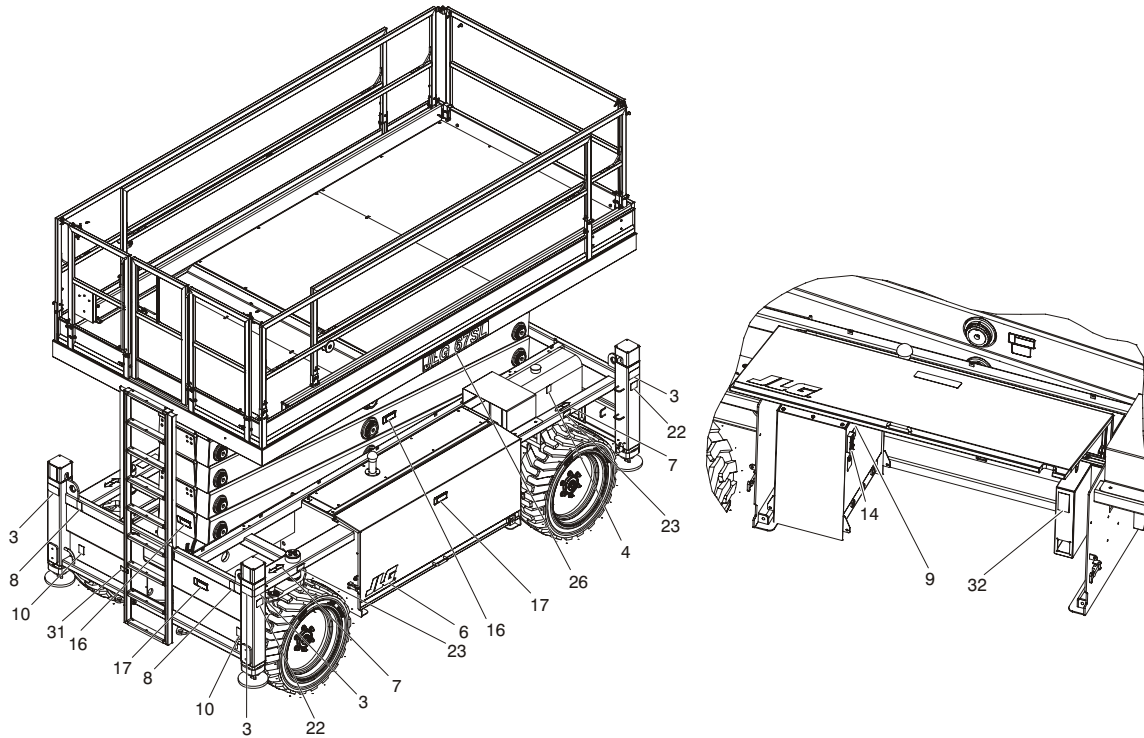

Figure 3-7. Decal Location (ANSI) - Sheet 2 of 2

## SECTION 3 - MACHINE CONTROLS

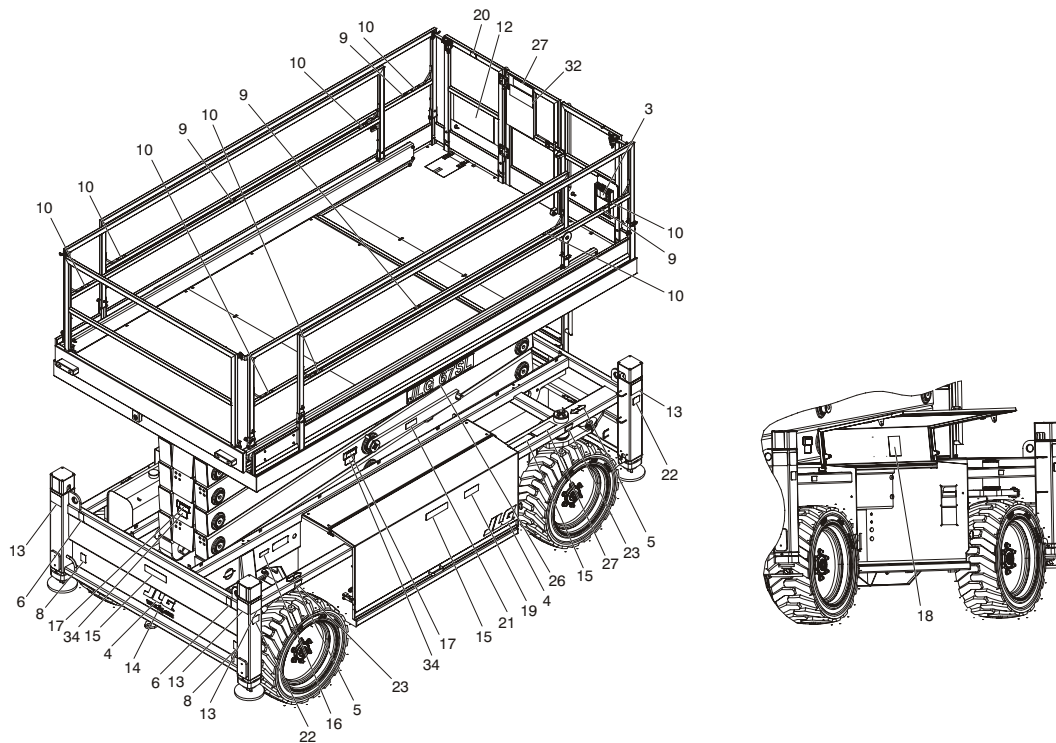

Figure 3-8. Decal Location (CSA) - Sheet 1 of 2

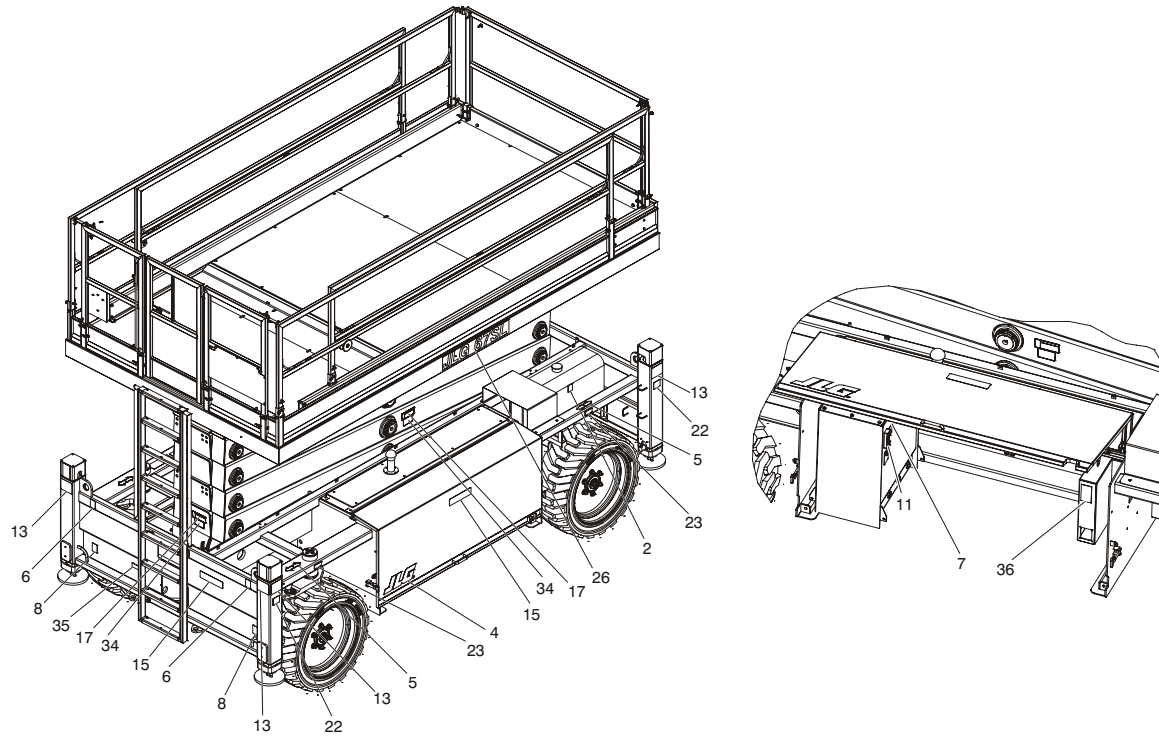

Figure 3-9. Decal Location (CSA) - Sheet 2 of 2

## SECTION 3 - MACHINE CONTROLS

**Table 3-1. Decal Legend**

Item #	ANSI (0275932-G)	CSA English/French (1001092749-F)
1	--	--
2	--	1701505
3	1701214	1701640
4	1701505	1702773
5	1701640	1703687
6	1702773	1703811
7	1703687	1703812
8	1703811	1703814
9	1703812	1703819
10	1703814	1704277
11	1703816	1704412
12	1703819	1704684
13	1704277	1704690
14	1704412	1704885
15	1704885	1705040
16	1705694	1705303
17	1705695	1705694

**Table 3-1. Decal Legend**

Item #	ANSI (0275932-G)	CSA English/French (1001092749-F)
18	--	1001103745
19	1706482	1706482
20	1706485	1706485
21	1706487	1706487
22	1706559	1706559
23	1706560	1706560
24	1001103745	--
25	--	--
26	1707182	1707182
27	1707185	1707187
28	1707187	--
29 - 30	--	--
31	1703464	--
32	1706098	1001092736
33	--	--
34	--	1705717
35	--	1703464
36	--	1706098

## SECTION 4. MACHINE OPERATION

### 4.1 DESCRIPTION

#### General Description of the Functions and Components.

The normal location to operate the machine is on the platform. However, the platform control box can be disconnected from the platform location and plugged in (for emergency use, and loading onto a transport vehicle) at the distribution terminal inside the valve compartment of the machine.



### 4.2 STARTING

Ensure Battery Disconnect Switch is not cutting off the battery power. On the Ground Control Console, select the operating position (platform vs. ground).

**NOTE:** *If Glow Plug LED illuminates, wait until the LED goes out before attempting to start the engine.*

#### **⚠ WARNING**

**ENGINE EXPLOSION HAZARD. MACHINE IS EQUIPPED WITH A COLD START AID. DO NOT USE ADDITIONAL ETHER. FAILURE TO COMPLY COULD RESULT IN DEATH OR SERIOUS INJURY.**

On the selected Operating Console, press the Engine Start Switch up and hold to start the engine. Release the switch once engine starts. On the ground control console, select Outriggers active or disabled.

The Engine Start Switch can also be used to shut the engine off when the switch is pressed down.

**NOTE:** *The Start Button on the Engine Control box can also be used to start the engine (refer to Figure 3-2.).*

### 4.3 LIFTING AND LOWERING

#### **WARNING**

DO NOT RAISE PLATFORM EXCEPT ON A FIRM UNIFORM SURFACE FREE OF OBSTRUCTIONS AND HOLES.

#### **CAUTION**

ENSURE SCISSOR ARM AREA IS FREE OF PERSONNEL PRIOR TO LOWERING PLATFORM.

DO NOT LOWER THE PLATFORM WITHOUT COMPLETELY RETRACTING THE PLATFORM EXTENSION.

#### Lifting:

1. If operating from the ground control console:
  - a. Lift up on the Platform Lift/Lower Switch to achieve desired elevation.
2. If operating from the platform control console:
  - a. Position the Drive/Lift Select Switch to the "Lift" position. Press and hold the enable trigger on the front of the joystick while moving the joystick forward to raise the platform to desired elevation. Once the

trigger is released or the joystick is returned to the neutral position, the movement will stop.

#### Lowering:

1. If operating from the ground control console:
  - a. Press down on the Platform Lift/Lower Switch to achieve desired elevation.
2. If operating from the platform control console:
  - a. Position the Drive/Lift Select Switch to the "Lift" position. Press and hold the enable trigger on the front of the joystick while moving the joystick backward to lower the platform to desired elevation. Once the trigger is released or the joystick is returned to the neutral position, the movement will stop.

**NOTE:** *When the machine is in "Drive Mode," the lifting and lowering functions are deactivated. Manual descent is the only allowable platform movement when in "Drive Mode."*

*The machine is equipped with gravity descent. The engine does not need to be running to lower the platform.*

## 4.4 AUTOMATIC SELF LEVELING CHASSIS

The machine is equipped with an auto leveling feature that allows the operator to automatically level the machine. When the machine is leveled, the lift function is automatically enabled. The indicator LED's on the Main Terminal Box will also indicate when the machine is level ( See Figure 3-3. on page 3-4 and page 3-5 for an explanation of the LED's). This function can be turned on or off at the ground control station.

With the auto leveling function selected, the outriggers are deployed by using the lift controller. Joystick forward will extend the outriggers and Joystick back will retract the outriggers.

All outriggers must be extended and in contact with the support surface before the platform is lifted from the stowed position. If one or more outriggers, despite being fully extended, is not in contact with the supporting surface the outriggers must be retracted and the machine moved to a more appropriate position.

To retract the outriggers, activate the lowering function with the joystick. When the platform is completely lowered, the outriggers will begin to retract. Once all outriggers are completely retracted, the drive function will be enabled and the Drive Enabled LED on the platform control console will illuminate.

### **WARNING**

**IF THE MACHINE BECOMES UNLEVEL, CAREFULLY LOWER THE PLATFORM AND REPOSITION THE MACHINE.**

### **NOTICE**

**ALWAYS BE SURE THAT THE OPERATING SURFACE THE MACHINE IS TO BE USED ON IS FIRM AND FREE OF ANY VOIDS OR OBSTRUCTIONS THAT MAY CAUSE THE OUTRIGGERS TO NOT PERFORM PROPERLY.**

### 4.5 DRIVING THE MACHINE FROM THE PLATFORM

To activate the drive of the machine, the controller (joystick) has to be moved forward for forward-drive and back for reverse-drive. The controller has a neutral zone of about  $\pm 7\%$  of the total possible moving distance. After reaching the end of the neutral zone, the machine starts to move.

#### **WARNING**

**DO NOT DRIVE WITH PLATFORM RAISED EXCEPT ON A SMOOTH, FIRM AND LEVEL SURFACE FREE OF OBSTRUCTIONS AND HOLES.**

**TO AVOID LOSS OF TRAVEL CONTROL OR UPSET ON GRADES AND SIDESLOPES, DO NOT DRIVE MACHINE ON GRADES OR SIDESLOPES EXCEEDING THOSE SPECIFIED. REFERENCE FIGURE 4-1., GRADE AND SIDESLOPE.**

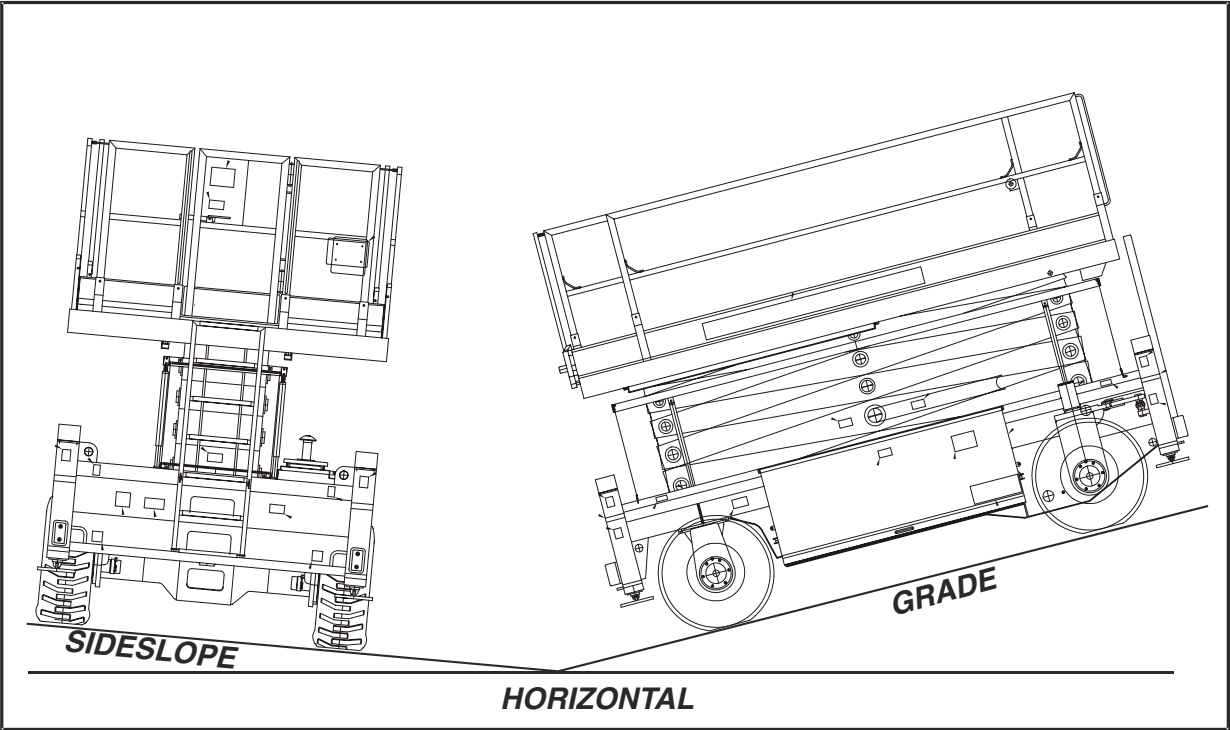

**Figure 4-1. Grade and Sideslope**

### 4.6 STEERING

The steer function is operated by depressing the two positioned button on top of the joystick. Pressing and holding the button to the right will turn the wheels to the right. Release the button when desired direction is achieved. When the button is released, the wheels will remain in the turned position. To straighten and/or turn to the left, the button must be pushed and held in the opposite direction (left in this case). The same procedure applies for straightening or turning right when wheels are in left turn position.

### 4.7 HYDRAULIC PLATFORM EXTENSION

With the lift/drive/extension switch in the extension position, the platform can be hydraulically extended. The function is activated by moving the controller forward to extend and backwards to retract.

### 4.8 EMERGENCY LOWERING - MANUAL DESCENT

All control switches have to be set to the neutral position. Next, the emergency lowering valve, which is located on the lifting ram, can be opened hydraulically by a hand pump located inside the hydraulic compartment. Once the lowering is completed all levers of the emergency lowering function have to be put into the neutral position. Refer to Section 5.3, Manual Procedures for instructions on manual descent.

### 4.9 PARKING AND STOWING

When machine use is completed, the machine has to be fully lowered and the battery isolator switch should be turned off.

#### **NOTICE**

**THE MACHINE SHOULD BE LOCKED BY THE KEYSWITCH ON THE GROUND CONTROL PANEL TO AVOID THE USE BY ANY UNAUTHORIZED PERSONNEL.**

In case the machine is not used for a longer period of time, the batteries should be charged once every two weeks due to the self discharge and power consumption of the machine at rest.

### 4.10 TIE DOWN/LIFT LUGS

#### Tie Down

When transporting the machine, the platform extension must be fully retracted and the platform fully lowered in the stowed position with the machine securely tied down to the truck or trailer deck. Refer to the tie down lugs in Figure 4-2., Lifting and Tie Down Points.

#### Lifting

If it becomes necessary to lift the machine, it is possible to do so from the lifting lugs located at the four corners of the machine. These lugs enable the machine to be lifted using cranes or suitable lifting devices.

**NOTE:** *If lifting becomes necessary from the lifting lugs, JLG Industries Inc. recommends the use of a proper spreader bar and straps/chains to avoid damage to the machine. Cranes or other lifting devices must be capable of handling the weights listed in the Operating Specifications table in section 6 of this manual.*

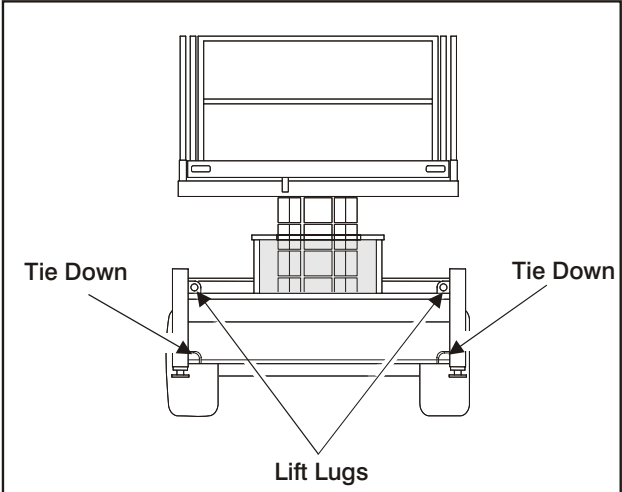
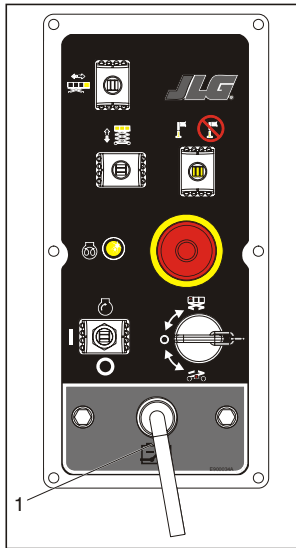

Figure 4-2. Lifting and Tie Down Points

## **4.11 TRANSPORT AND STORAGE OF THE MACHINE**

**NOTICE**

**DURING TRANSPORT THE BATTERY DISCONNECT SWITCH SHOULD BE DISCONNECTED.**



**1. Battery Disconnect Switch**

The control box must be unplugged during the transport of the machine. The socket at the platform must be closed, whenever the control box is not plugged in. This is the best way to prevent any damages due to moisture and transport to the electrical components of the machine.

- Ensure the control box is stored in a safe, dry location and the main joystick controller is not affected by any harsh forces.

## **SECTION 5. EMERGENCY PROCEDURES**

### **5.1 GENERAL**

This section provides information on the procedures to be followed and on the systems and controls to be used in the event an emergency situation is encountered during machine operation. Prior to operation of the machine and periodically thereafter, the entire operating manual, including this section, should be reviewed by all personnel whose responsibilities include any work or contact with the machine.

#### **Emergency Stop Switch**

These large red buttons, one located outside the valve compartment and one at the Platform Control Station, will immediately stop the machine when depressed.

#### **Platform Caught Overhead**

If the platform becomes jammed or snagged in overhead structures or equipment, do not continue operation of the machine from either the platform or the ground until the operator and all personnel are safely moved to a secure location. Only then should an attempt be made to free the platform using any necessary equipment and personnel. Do not operate controls to cause one or more wheels to leave the ground.

#### **Righting of Tipped Machine**

A forklift of suitable capacity or equivalent equipment should be placed under the elevated side of the chassis, with a crane or other suitable lifting equipment used to lift the platform while the chassis is lowered by the forklift or other equipment.

#### **Post-Incident Inspection**

Following any incident, thoroughly inspect the machine and test all functions first from the ground controls, then from the platform controls. Do not lift above 10 ft (3 m) until you are sure that all damage has been repaired, and that all controls are operating correctly.

### 5.2 EMERGENCY OPERATION

#### Use of Ground Controls

#### **NOTICE**

**KNOW HOW TO USE THE GROUND CONTROLS IN AN EMERGENCY SITUATION.**

Ground personnel must be thoroughly familiar with the machine operating characteristics and the ground control functions. Training should include operation of the machine, review and understanding of this section and hands-on operation of the controls in simulated emergencies.

#### **Operator Unable to Control Machine**

1. Operate the machine from ground controls **ONLY** with the assistance of other personnel and equipment (cranes, overhead hoists, etc.) as may be required to safely remove the danger or emergency condition.
2. Other qualified personnel on the platform may use the platform controls. **DO NOT CONTINUE OPERATION IF CONTROLS DO NOT FUNCTION NORMALLY.**

3. Cranes, forklift trucks or other equipment, which may be available, are to be used to stabilize motion of the machine in case machine controls are inadequate or malfunction when used prior to removing platform occupants.

#### **Incident Notification**

It is imperative that JLG Industries, Inc. be notified immediately of any incident involving a JLG product. Even if no injury or property damage is evident, JLG should be contacted by telephone and provided with all necessary details at:

877-554-7233 or 240-420-2661

It should be noted that failure to notify the Manufacturer of an incident involving a JLG Industries product within 48 hours of such an occurrence may void any warranty consideration on that particular machine.

## **5.3 MANUAL PROCEDURES**

### **Manual Platform Deck Retraction**

**NOTE:** *The platform deck extension should be retracted before the platform lowering begins.*

1. Locate the valve block and hand pump inside the hydraulic cover on the right side of the machine.
2. Turn valve knob on the manual hand pump clockwise until tight.

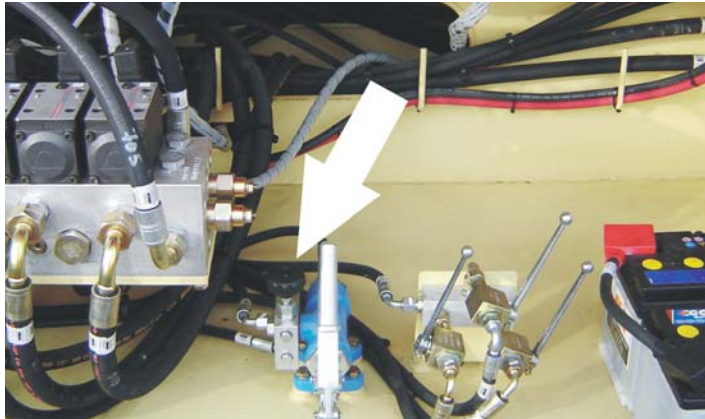

**NOTE:** *Step 2 applies only to machines prior to S/N 1200021189.*

3. Locate the middle valve handle on the small valve bank as shown and pull down to engage.

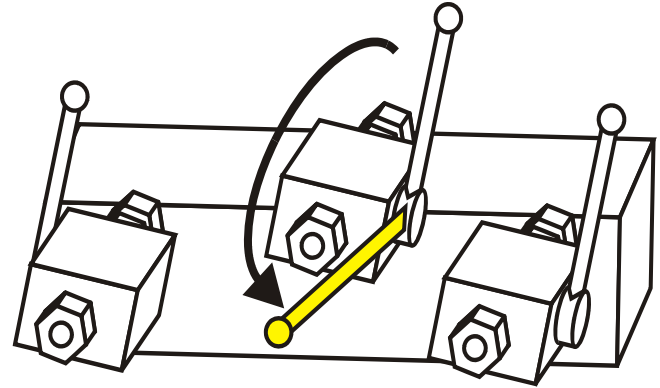

**NOTE:** *Step 3 applies only to machines prior to S/N 1200021189.*

## SECTION 5 - EMERGENCY PROCEDURES

---

4. Locate separate valve handle in the storage bag and place on the push cylinder valve of the main hydraulic block. (1<sup>st</sup> section from the left).



**NOTE:** Valve handles are located in plastic storage bag within valve compartment.

5. Open valve by pulling handle down.

6. While continuing to hold the valve open, activate the manual hand pump by pumping back and forth until the deck extension is fully retracted.
7. After manual platform deck retraction is complete, release valve on the valve bank and remove handle from valve. Return the valve handle on the small valve bank back to its original position (if applicable). Turn the valve on the manual hand pump counterclockwise until fully open (if applicable). Push pump handle forward.
8. Remove handle and place back into storage bag.

### Manual Platform Lowering (Prior to S/N 1200021189)

**NOTE:** The manual descent system is provided as an emergency means to lower personnel from the platform.

1. Locate the valve block and hand pump inside the hydraulic cover on the right side of the machine.
2. Turn valve knob on the manual hand pump clockwise until tight.

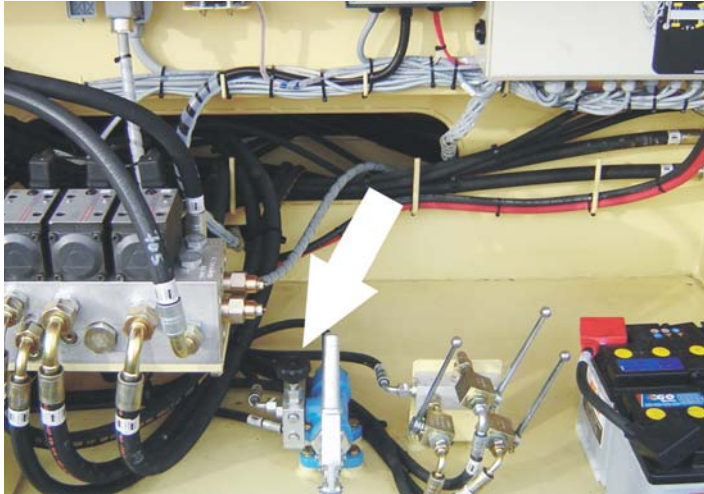

3. Locate the valve handle on the left side of the small valve bank, as shown below, and pull down to engage.

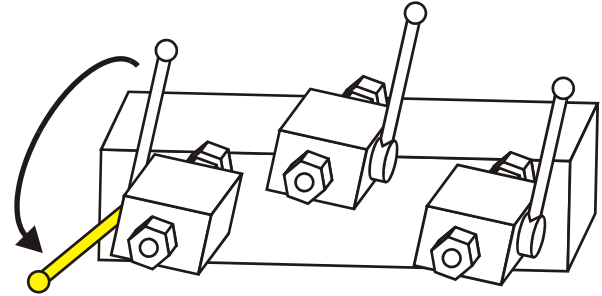

4. Activate the manual hand pump by pumping back and forth.

#### **⚠ WARNING**

**PLATFORM WILL CONTINUE TO DESCEND ONCE MOVEMENT IS STARTED. TO STOP PLATFORM DESCENT, TURN VALVE KNOB COUNTERCLOCKWISE.**

5. After manual lowering is complete, release valve on the valve bank and remove handle from valve. Return the valve handle on the small valve bank back to its original position (if applicable). Turn the valve on the manual hand pump counterclockwise until fully open (if applicable). Push pump handle forward.

## SECTION 5 - EMERGENCY PROCEDURES

### Manual Platform Lowering (S/N 1200021189 to Present)

**NOTE:** The manual descent system is provided as an emergency means to lower personnel from the platform.

1. Locate the valve block and manual hand pump inside the hydraulic cover on the right side of the machine.

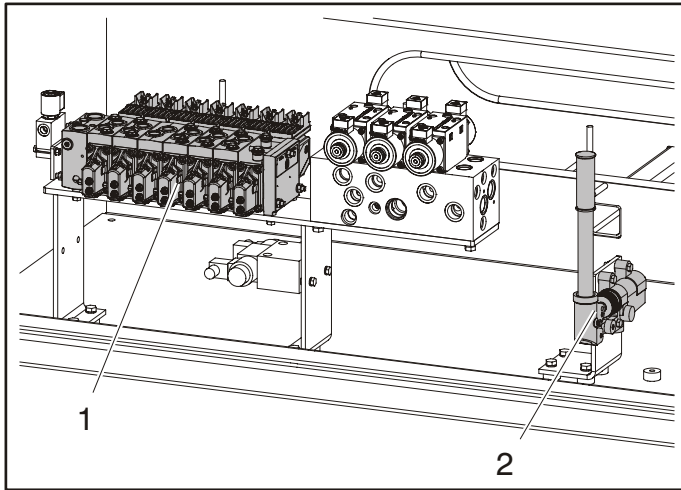

1. Main Valve Block

2. Manual Hand Pump

2. Place the handle on the second section of the main valve block (3) as shown and pull down to engage.

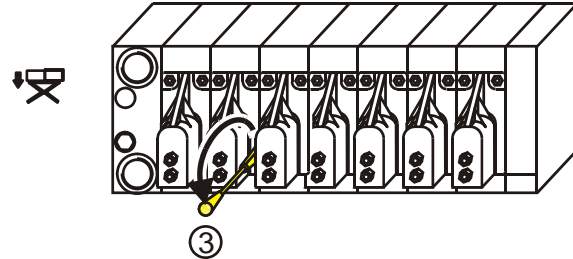

**NOTE:** Valve handles are located in plastic storage bag within valve compartment.

3. Activate the manual hand pump by pumping back and forth (2).

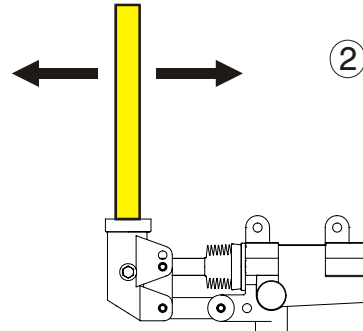

** WARNING**

PLATFORM WILL CONTINUE TO DESCEND ONCE MOVEMENT IS STARTED. TO STOP PLATFORM DESCENT, RELEASE THE HANDLE ON THE MAIN VALVE BLOCK

4. After manual deck retraction is complete, release the handle on the main valve block.

## **5.4 EMERGENCY TOWING**

** WARNING**

RUNAWAY VEHICLE/MACHINE HAZARD. MACHINE HAS NO TOWING BRAKES. TOWING VEHICLE MUST BE ABLE TO CONTROL MACHINE AT ALL TIMES. ON-HIGHWAY TOWING NOT PERMITTED. FAILURE TO FOLLOW INSTRUCTIONS COULD CAUSE SERIOUS INJURY OR DEATH.

MAXIMUM TOWING SPEED 5 M.P.H. (8 K.M.H.) FOR NO LONGER THAN 30-45 MINUTES.

MAXIMUM TOWING GRADE 25%.

### **Prior to Towing**

Prior to towing the machine, complete the following:

** CAUTION**

DO NOT TOW MACHINE WITH ENGINE OPERATING OR DRIVE HUBS ENGAGED.

1. Completely lower platform.
2. Disconnect drive hubs by inverting disconnect cap. (See Figure 5-1.) After towing the machine, complete the following:

## SECTION 5 - EMERGENCY PROCEDURES

---

- a. Reconnect drive hubs by inverting disconnect cap.  
(See Figure 5-1.)

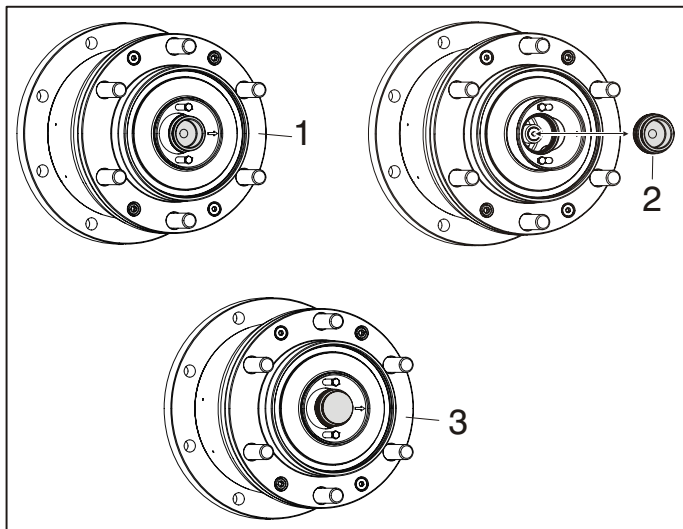

1. Hub Connected
2. Disconnect Cap
3. Hub Disconnected

**Figure 5-1. Drive Disconnect Hub**

## SECTION 6. GENERAL SPECIFICATIONS AND OPERATOR MAINTENANCE

### 6.1 INTRODUCTION

This section of the manual provides additional necessary information to the operator for proper operation and maintenance of this machine.

The maintenance portion of this section is intended as information to assist the machine operator to perform daily maintenance tasks only, and does not replace the more thorough Preventive Maintenance and Inspection Schedule included in the Service and Maintenance Manual.

**Other Publications Available Specific to this Machine:**

Service and Maintenance Manual .....	3121322
Illustrated Parts Manual .....	3121323

## SECTION 6 - GENERAL SPECIFICATIONS AND OPERATOR MAINTENANCE

### 6.2 OPERATING SPECIFICATIONS

**Table 6-1. Operating Specifications**

Maximum Working Height: with outriggers deployed with outriggers stowed	73.2 ft (22.3 m) 56.8 ft (17.3 m)
Maximum Platform Height: with outriggers deployed with outriggers stowed	66.7 ft (20.3 m) 50 ft (15.3 m)
Turning Radius (Outside)	14.8 ft (4.5 m)
Maximum Work Load (Capacity) - Main Platform/ Platform Extension	1650 lbs/1100 lbs (750 kg/500 kg)
Maximum Number of Persons	4
Tools and Equipment Main Platform / Platform Extension	1300 lbs/397 lbs (430 kg/180 kg)
Maximum Horizontal Manual Side Force	200 Lb force (890N)
Tilt Sensor Setting	3°
Maximum Operating Wind Speed	28 mph (12.5 m/s)
Gross Machine Weight (Approximate)	25,132 lbs (11,400 kg)

**Table 6-1. Operating Specifications**

Drive Speed (slow)	0.4 mph (0.6 ft/sec) (0.2 m/s)
Drive Speed (fast)	2.2 mph (3.2 ft/sec) (1 m/s))
Lift Speed (Platform Empty)	60 sec
Lowering Speed	60 sec
Sideslope (Machine Stowed)	5°
Gradeability (Machine Stowed)	25%
Maximum Operating Hydraulic Pressure	3046 psi (210 bar)
Power Supply	Diesel Engine
Maximum Ground Bearing Pressure: Outrigger Pads Tires	128 psi (9 kg/cm <sup>2</sup> ) 71 psi (5 kg/cm <sup>2</sup> )
Maximum Tire Load	9700 lbs (4400 kg)
Maximum Outrigger Pad Load	9548 lbs (4290 kg)
Electrical System Voltage	24 V
Ground Clearance	0.9 ft (0.27 m)

## SECTION 6 - GENERAL SPECIFICATIONS AND OPERATOR MAINTENANCE

### Dimensional Data

**Table 6-2. Dimensional Data**

Transport Height (rails up / rails down)	12.5 ft / 9.9 ft (3.8 m / 3m)
Platform dimensions - extension retracted	15 x 7.9 ft (4.6 x 2.4 m)
Platform dimensions - extension extended	24.3 x 7.9 ft (7.4 x 2.4 m)
Transport Dimensions	15.9 x 7.9 ft (4.8 x 2.4m)

### Capacities

**Table 6-3. Capacities**

Fuel Tank	23.8 gal (90 L)
Hydraulic Tank	35.7 gal (135 L)
Engine Crankcase with Filter without Filter	11 qt (10.5 L) 10.6 qt (10 L)

### Tires

**Table 6-4. Tire Specifications**

Size	355/55D625
Ply Rating	14
Load Range	G
Tire Inflation (Foam Fill)	90 psi (6.2 bar)
Max Tire Load	9700 lbs (4400 kg)

## SECTION 6 - GENERAL SPECIFICATIONS AND OPERATOR MAINTENANCE

---

### Engine

**Table 6-5. Engine Specifications**

Type	Deutz F3L 2011	Deutz D2011 L03i
Number of Cylinders	3	
Displacement	140.4 in <sup>3</sup> (2.3L)	2331 cm <sup>3</sup>
Bore	3.7 in (94 mm)	
Stroke	4.4 in (112 mm)	
Fuel Type	Diesel	

**Table 6-6. Engine Battery Specifications**

Voltage	12V
Cranking Performance	100
Reserve Capacity	880

### Component Weights

**Table 6-7. Component Weights**

Fixed Platform	1,874 lb (850 kg)
Chassis with Foam Filled Tires	8,378 lb (3,800 kg)
Arm Assembly	11,244 lb (5,100 kg)
Lift Cylinder	992 lbs (450 kg)

# SECTION 6 - GENERAL SPECIFICATIONS AND OPERATOR MAINTENANCE

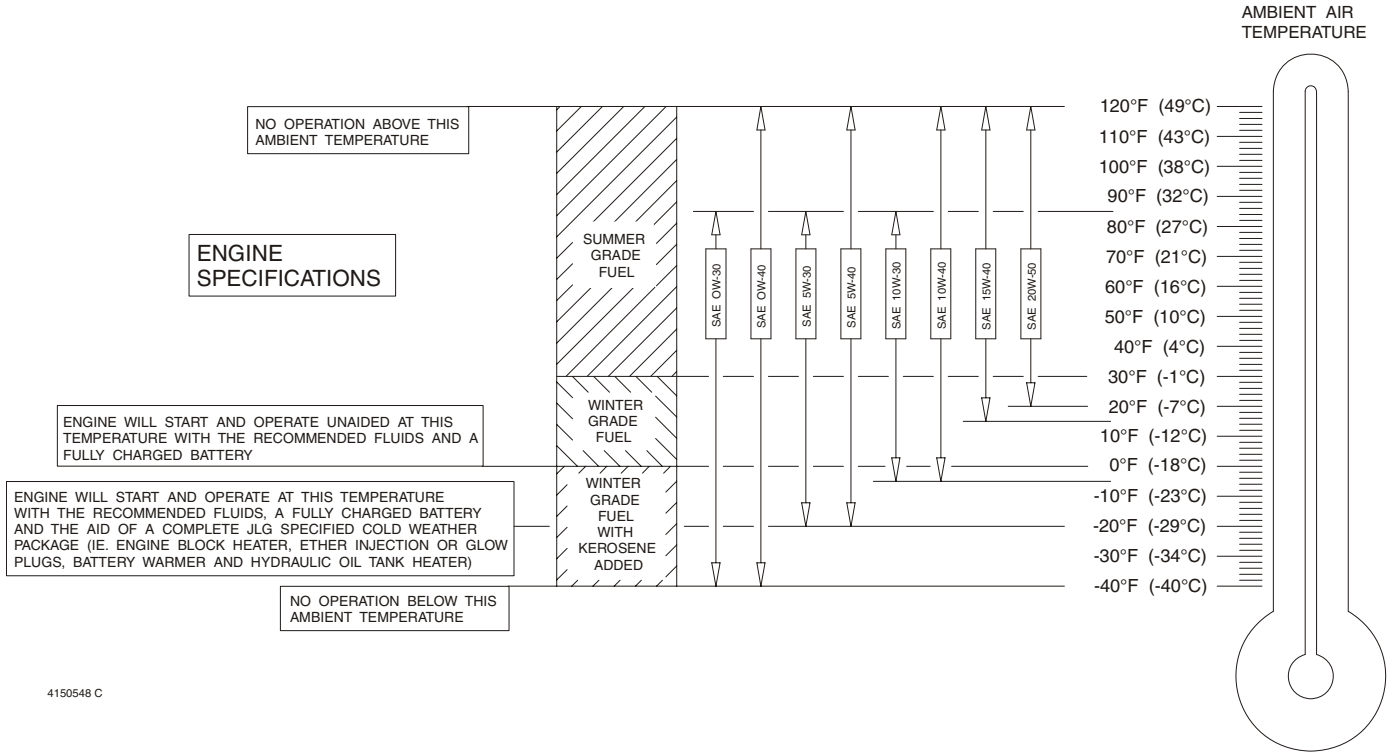

4150548 C

Figure 6-1. Engine Operating Temperature Specifications - Sheet 1 of 2

# SECTION 6 - GENERAL SPECIFICATIONS AND OPERATOR MAINTENANCE

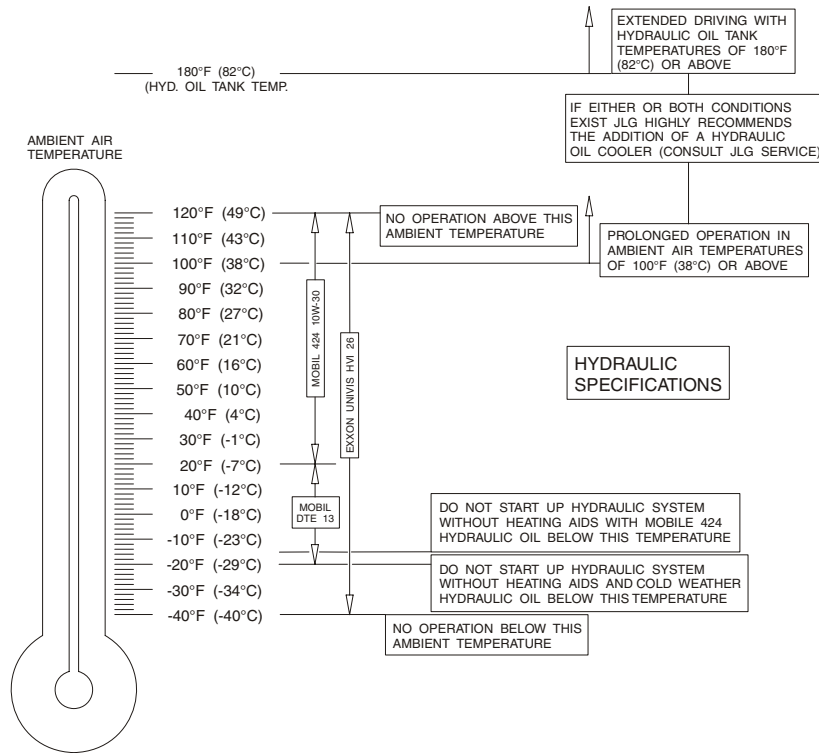

NOTE:

- 1) RECOMMENDATIONS ARE FOR AMBIENT TEMPERATURES CONSISTENTLY WITHIN SHOWN LIMITS
- 2) ALL VALUES ARE ASSUMED TO BE AT SEA LEVEL

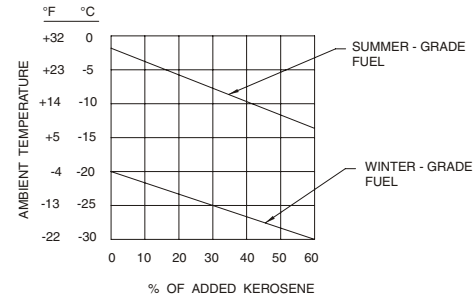

Figure 6-2. Engine Operating Temperature Specifications - Sheet 2 of 2

## SECTION 6 - GENERAL SPECIFICATIONS AND OPERATOR MAINTENANCE

### Lubrication

Hydraulic Oil

**Table 6-8. Hydraulic Oil**

HYDRAULIC SYSTEM OPERATING TEMPERATURE RANGE	SAE VISCOSITY GRADE
0° to +23°F (-18° to -5°C)	10W
0° to +210°F (-18° to +100°C)	10W-20, 10W-30
+50° to +210°F (+10° to +100°C)	20W-20

**NOTE:** Hydraulic oils must have anti-wear qualities at least to API Service Classification GL-3, and sufficient chemical stability for mobile hydraulic system service. JLG Industries recommends Mobilfluid 424 hydraulic oil, which has an SAE viscosity index of 152.

**NOTE:** When temperatures remain below 20°F (-7°C), JLG Industries recommends the use of Mobil DTE13.

**NOTE:** Aside from JLG recommendations, it is not advisable to mix oils of different brands or types, as they may not contain the same required additives or be of comparable viscosities. If use of hydraulic oil other than Mobilfluid 424 is desired, contact JLG Industries for proper recommendations.

Lubrication Specifications

**Table 6-9. Lubrication Specifications**

KEY	SPECIFICATIONS
MPG	Multipurpose Grease having a minimum dripping point of 350°F (177°C). Excellent water resistance and adhesive qualities, and being of extreme pressure type. (Timken OK 40 pounds minimum.)
EPGL	Extreme Pressure Gear Lube (oil) meeting API service classification GL-5 or MIL-Spec MIL-L-2105.
EO	Engine (crankcase) Oil. Gas - API SF/SG class, MIL-L-2104. Diesel - API CC/CD class, MIL-L-2104B/MIL-L-2104C.
HO	Hydraulic Oil. API service classification GL-3, e.g. Mobil 424.

**6.3 OPERATOR MAINTENANCE**

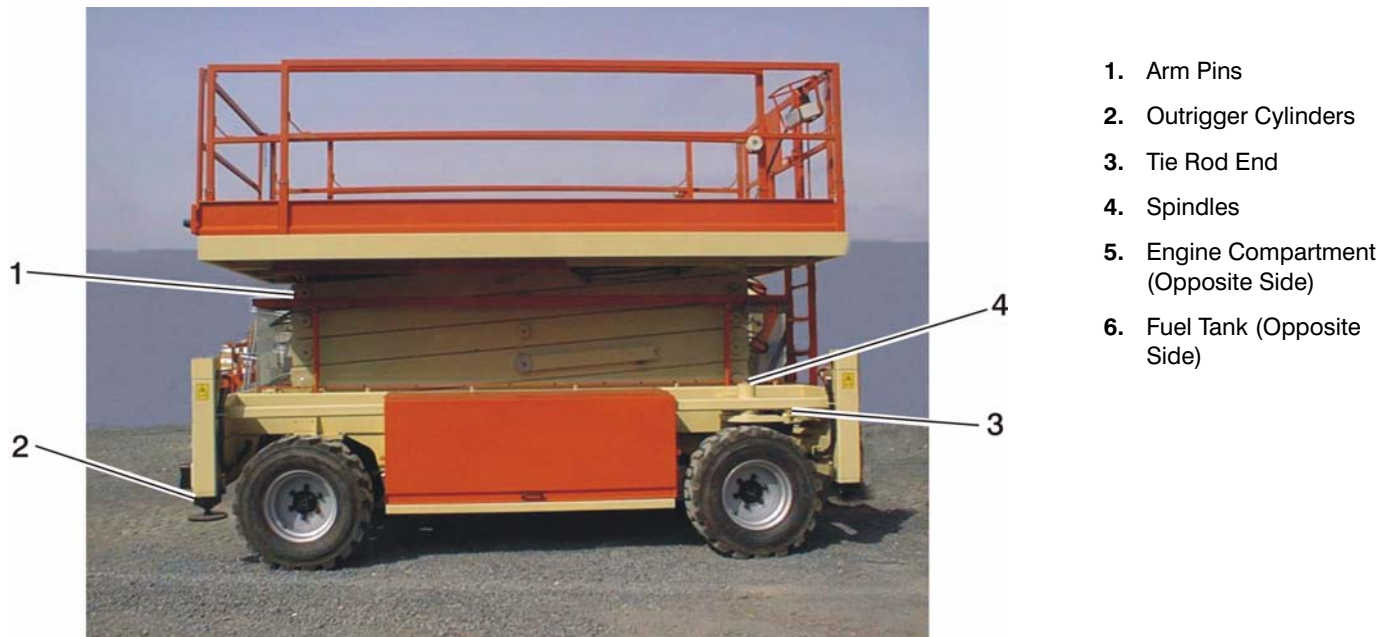

**Figure 6-3. Operator Maintenance and Lubrication Diagram**

## SECTION 6 - GENERAL SPECIFICATIONS AND OPERATOR MAINTENANCE

**NOTE:** The following numbers correspond with those in Figure 6-3., Operator Maintenance and Lubrication Diagram.

**NOTE:** Be sure to grease all like items on the opposite side of machine.

### 1. Arm Pin



- Lube Points - 36 Grease Fittings
- Capacity - As Required
- Lube - MPG
- Interval - As Required

### 2. Outrigger Cylinders



- Lube Points - 4 Grease Fittings
- Capacity - As Required
- Lube - MPG
- Interval - As Required

## SECTION 6 - GENERAL SPECIFICATIONS AND OPERATOR MAINTENANCE

### 3. Tie Rod End



- Lube Points - 2 Grease Fittings
- Capacity - As Required
- Lube -MPG
- Interval - As Required

### 4. Spindles



- Lube Points - 2 Grease Fittings
- Capacity - As Required
- Lube - MPG
- Interval - As Required

## SECTION 6 - GENERAL SPECIFICATIONS AND OPERATOR MAINTENANCE

### 5. Engine Compartment

#### a. Engine Oil Check/Fill



- Lube Points - Fill Cap and Dip Stick
- Capacity - See Engine Manual
- Lube - EO SAE 20W20
- Interval - Every 3 months or 150 hours of operation

#### b. Air Filter



- Lube Points - Replaceable Element
- Interval - Every 6 months or 300 hours of operation

## SECTION 6 - GENERAL SPECIFICATIONS AND OPERATOR MAINTENANCE

### c. Hydraulic Oil Check/Fill

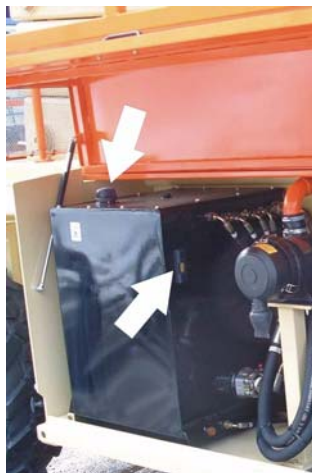

- Lube Points - Fill Cap and Site Gage
- Capacity - 68.7 gal (260 L)
- Lube - HO
- Interval - Check oil daily, change every 1200 hours of operation

### 6. Fuel Tank



- Capacity - 90 L (23.8 gal)
- Lube - Diesel Fuel
- Interval - Check fuel periodically during each use

### 6.4 TIRES AND WHEELS

#### Tire Damage

For pneumatic tires, JLG Industries, Inc. recommends that when any cut, rip, or tear is discovered that exposes sidewall or tread area cords in the tire, measures must be taken to remove the JLG product from service immediately. Arrangements must be made for replacement of the tire or tire assembly.

For polyurethane foam filled tires, JLG Industries, Inc. recommends that when any of the conditions listed below are discovered, measures must be taken to remove the JLG product from service immediately and arrangements must be made for replacement of the tire or tire assembly.

- a smooth, even cut through the cord plies which exceeds 3 inches (7.5 cm) in total length
- any tears or rips (ragged edges) in the cord plies which exceeds 1 inch (2.5 cm) in any direction
- any punctures which exceed 1 inch (2.5cm) in diameter
- any damage to the bead area cords of the tire

If a tire is damaged but is within the above noted criteria, the tire must be inspected on a daily basis to insure the damage has not propagated beyond the allowable criteria.

#### Tire Replacement

JLG recommends a replacement tire be the same size, ply and brand as originally installed on the machine. Please refer to the JLG Parts Manual for the part number of the approved tires for a particular machine and model. If not using a JLG approved replacement tire, it is recommended that replacement tires have the following characteristics:

- Equal or greater ply/load rating and size of original.
- Tire tread contact width equal or greater than original.
- Wheel diameter, width, and offset dimensions equal to the original.

Unless specifically approved by JLG Industries Inc. do not replace a foam filled tire assembly with a pneumatic tire. When selecting and installing a replacement tire, ensure that all tires are inflated to the pressure recommended by JLG. Due to size variations between tire brands, both tires on the same axle should be the same.

## SECTION 6 - GENERAL SPECIFICATIONS AND OPERATOR MAINTENANCE

### Wheel Replacement

The rims installed on each product model have been designed for stability requirements which consist of track width, tire pressure, and load capacity. Size changes such as rim width, center piece location, larger or smaller diameter, etc., without written factory recommendations, may result in an unsafe condition regarding stability.

### Wheel Installation

It is extremely important to apply and maintain proper wheel mounting torque.

#### **⚠ WARNING**

**WHEEL NUTS MUST BE INSTALLED AND MAINTAINED AT THE PROPER TORQUE TO PREVENT LOOSE WHEELS, BROKEN STUDS, AND POSSIBLE DANGEROUS SEPARATION OF WHEEL FROM THE AXLE. BE SURE TO USE ONLY THE NUTS MATCHED TO THE CONE ANGLE OF THE WHEEL.**

Tighten the lug nuts to the proper torque to prevent wheels from coming loose. Use a torque wrench to tighten the fasteners. If you do not have a torque wrench, tighten the fasteners with a lug wrench, then immediately have a service garage or dealer tighten the lug nuts to the proper torque. Over-tightening will result in breaking the studs or perma-

nently deforming the mounting stud holes in the wheels. The proper procedure for attaching wheels is as follows:

1. Start all nuts by hand to prevent cross threading. DO NOT use a lubricant on threads or nuts.
2. Tighten nuts in the following sequence:.

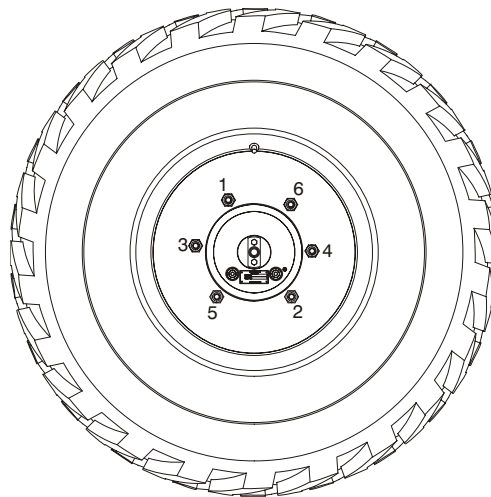

6 LUG PATTERN

## SECTION 6 - GENERAL SPECIFICATIONS AND OPERATOR MAINTENANCE

---

3. The tightening of the nuts should be done in stages. Following the recommended sequence, tighten the nuts per wheel torque chart.

TORQUE SEQUENCE		
1st Stage	2nd Stage	3rd Stage
150-190 ft lbs (210 - 270 Nm)	230 - 270 ft lbs (320-380 Nm)	305 - 343 ft lbs ( 440 - 480 Nm)

4. Wheel nuts should be torqued after the first 50 hours of operation and after each wheel removal. Check torque every 3 months or 150 hours of operation.









An Oshkosh Corporation Company

# TRANSFER OF OWNERSHIP

## To Product Owner:

If you now own but **ARE NOT** the original purchaser of the product covered by this manual, we would like to know who you are. For the purpose of receiving safety-related bulletins, it is very important to keep JLG Industries, Inc. updated with the current ownership of all JLG products. JLG maintains owner information for each JLG product and uses this information in cases where owner notification is necessary.

Please use this form to provide JLG with updated information with regard to the current ownership of JLG products. Please return completed form to the JLG Product Safety & Reliability Department via facsimile or mail to address as specified below.

Thank You,  
Product Safety & Reliability Department  
*JLG Industries, Inc.*  
13224 Fountainhead Plaza  
Hagerstown, MD 21742  
USA  
Telephone: +1-717-485-6591  
Fax: +1-301-745-3713

**NOTE:** Leased or rented units should not be included on this form.

Mfg. Model: \_\_\_\_\_

Serial Number: \_\_\_\_\_

Previous Owner: \_\_\_\_\_

Address: \_\_\_\_\_

Country: \_\_\_\_\_ Telephone: (\_\_\_\_) \_\_\_\_\_

Date of Transfer: \_\_\_\_\_

Current Owner: \_\_\_\_\_

Address: \_\_\_\_\_

Country: \_\_\_\_\_ Telephone: (\_\_\_\_) \_\_\_\_\_

**Who in your organization should we notify?**

Name: \_\_\_\_\_

Title: \_\_\_\_\_







An Oshkosh Corporation Company

Corporate Office  
JLG Industries, Inc.  
1 JLG Drive  
McConnellsburg PA. 17233-9533  
USA

(717) 485-5161

(717) 485-6417

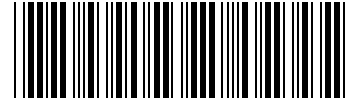

3121321

## JLG Worldwide Locations

JLG Industries (Australia)  
P.O. Box 5119  
11 Bolwarra Road  
Port Macquarie  
N.S.W. 2444  
Australia

+61 2 65 811111

+61 2 65 810122

JLG Latino Americana Ltda.  
Rua Eng. Carlos Stevenson,  
80-Suite 71  
13092-310 Campinas-SP  
Brazil

+55 19 3295 0407

+55 19 3295 1025

JLG Industries (UK) Ltd  
Bentley House  
Bentley Avenue  
Middleton  
Greater Manchester  
M24 2GP - England

+44 (0)161 654 1000

+44 (0)161 654 1001

JLG France SAS  
Z.I. de Baulieu  
47400 Failliet  
France

+33 (0)5 53 88 31 70

+33 (0)5 53 88 31 79

JLG Deutschland GmbH  
Max-Planck-Str. 21  
D - 27721 Ritterhude - Ihlpohl  
Germany

+49 (0)421 69 350 20

+49 (0)421 69 350 45

JLG Equipment Services Ltd.  
Rm 1107 Landmark North  
39 Lung Sum Avenue  
Sheung Shui N. T.  
Hong Kong

(852) 2639 5783

(852) 2639 5797

JLG Industries (Italia) s.r.l.  
Via Po. 22  
20010 Pregnana Milanese - MI  
Italy

+39 029 359 5210

+39 029 359 5845

JLG Europe B.V.  
Polaris Avenue 63  
2132 JH Hoofddorp  
The Netherlands

+31 (0)23 565 5665

+31 (0)23 557 2493

JLG Polska  
Ul. Krolewska  
00-060 Warszawa  
Poland

+48 (0)914 320 245

+48 (0)914 358 200

JLG Industries (Scotland)  
Wright Business Centre  
1 Lonmay Road  
Queenslie, Glasgow G33 4EL  
Scotland

+44 (0)141 781 6700

+44 (0)141 773 1907

Plataformas Elevadoras  
JLG Iberica, S.L.  
Trapadella, 2  
P.I. Castellbisbal Sur  
08755 Castellbisbal, Barcelona  
Spain

+34 93 772 4700

+34 93 771 1762

JLG Sverige AB  
Enkopingsvagen 150  
Box 704  
SE - 176 27 Jarfalla  
Sweden

+46 (0)850 659 500

+46 (0)850 659 534