



ACCESSORIES & OPTIONS

- 74 hp Engine
- Air Conditioning
- Air Shut-off Valve
- Arctic Package
- Auxiliary Electrics
- Boom Prop
- Brick Guards
- Enclosed Cab
- Fenders
- Hydraulic Coupler
- LED Worklight Package
- Load Stability Indication (LSI)
- Multifunction Display with Multi-Reverse Camera System
- Reverse Sensing System
- Ride Control
- Road Light Package
- Seatbelt Engagement & Operator Presence
- White Noise Back-up Alarm
- Wiper Package
- Work Lights

ATTACHMENTS

Standard Carriage	50-in 60-in 72-in	1.3-m 1.5-m 1.8-m
Side-Tilt Carriage	50-in 60-in 72-in	1.3-m 1.5-m 1.8-m
Swing 90° Carriage	72-in	1.8-m
Dual Fork Positioning Carriage	50-in	1.3-m
Side-Shift Carriage	48-in	1.2-m
Tower with Side Tilt Pallet Forks	8-ft 2.36-in x 4-in x 48-in 2.36-in x 5-in x 48-in 2.36-in x 5-in x 60-in	2.4-m 60-mm x 102-mm x 1.2-m 60-mm x 127-mm x 1.2-m 60-mm x 127-mm x 1.5-m
Lumber Forks	2.00-in x 6-in x 72-in 2.00-in x 7-in x 60-in 2.36-in x 6-in x 60-in	51-mm x 152-mm x 1.8-m 51-mm x 178-mm x 1.5-m 60-mm x 152-mm x 1.5-m
Cubing Forks	2-in x 2-in x 48-in	51-mm x 51-mm x 1.2-m
Material Bucket	72-in, 1.0-cu yd 96-in, 1.5-cu yd 102-in, 2.0-cu yd	1.8-m, 0.76-m ³ 2.4-m, 1.15-m ³ 2.6-m, 1.53-m ³
Truss Boom	12-ft, 2,000-lb 15-ft, 2,000-lb 3-ft w/ winch, 4,000-lb Capacity 12-ft w/ winch, 2,000-lb	3.7-m, 907-kg 4.6-m, 907-kg 0.9-m, 1,814-kg Capacity 2.4-m, 455-kg Capacity
Fork Mounted Work Platform	8-ft, 1,000-lb Capacity	
Lifting Hook-Fork Mounted		
Lifting Hook-Coupler Mounted		
Fork Mounted Extendable Truss		
Sheet Material Handler		

STANDARD SPECIFICATIONS

Performance

Rated Capacity	9,000-lb / 4,082-kg
Maximum Lift Height	43-ft / 13.1-m
Load at Max Height	7,000-lb / 3,175-kg
Maximum Forward Reach	30-ft 5-in / 9.3-m
Load at Max Reach	1,200-lb / 544-kg
Frame Leveling	10 Degrees
Lift Speed (boom retracted) Up	13 seconds
Lift Speed (boom retracted) Down	9 seconds
Boom Speed Extend	15 seconds
Boom Speed Retract	13 seconds
Top Travel Speed (4-Speed)	19 mph / 31 kph
Drawbar Pull (loaded)	22,751-lb / 101.2-kN
Outside Turning Radius	12-ft / 3.67-m
Operating Weight	24,912-lb / 11,300-kg

Engine

Make and Model	Cummins F3.8L
No. of Cylinders	4
Displacement	232-cu in / 3.8 L
Gross Power Basic	110 hp / 83 kW
Maximum Torque @ 1500 rpm	348-lb/ft / 472 Nm
Fuel Tank Capacity	38.3 gal / 145 L

Transmission

Powershift 4-speed forward and 3-speed reverse.

Axles

Trunnion mounted planetary steer axles. Integral steer cylinder. High bias limited slip differential on front axle.

Brakes

Service brakes are inboard wet disc brake on front and rear axles. Parking brakes are wet disc spring-applied hydraulic release on front axle.

Tires

Standard	370/75-28
Optional	Foam-Filled, Solid, Non-marking (Pneumatic, Foam-Filled or Solid), Pneumatic 14 x 24-16PR

Cab

- Adjustable suspension seat
- Anti-theft
- Certified ROPS/FOPS structure
- Clearsky Smart FleetTM Hardware (CS550)
- Horn
- Integrated arm rest
- LED motion/amber beacon (CS550)
- Single joystick controls
- Tilt on joystick

Steering 4-Wheel

Power steering.
Operator selectable 4-wheel circle, 4-wheel crab, 2-wheel front.

Instruments

- DEF gauge
- Engine oil pressure gauge
- Fuel gauge
- Hour meter
- Temperature gauge
- Volt meter

Hydraulic System-Implement

Capacity	40 gal / 151.4 L
----------	------------------

Max. auxiliary flow to the boom head 25 gpm/95 lpm. Load sense piston pump. Auxiliary hydraulics used for all attachments equipped with cylinders or other hydraulic components.

DIMENSIONS

All dimensions are approximate

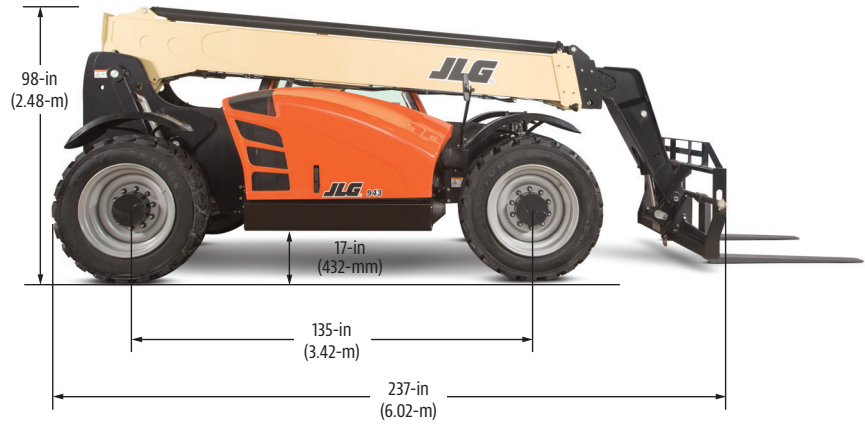

LOAD CHART

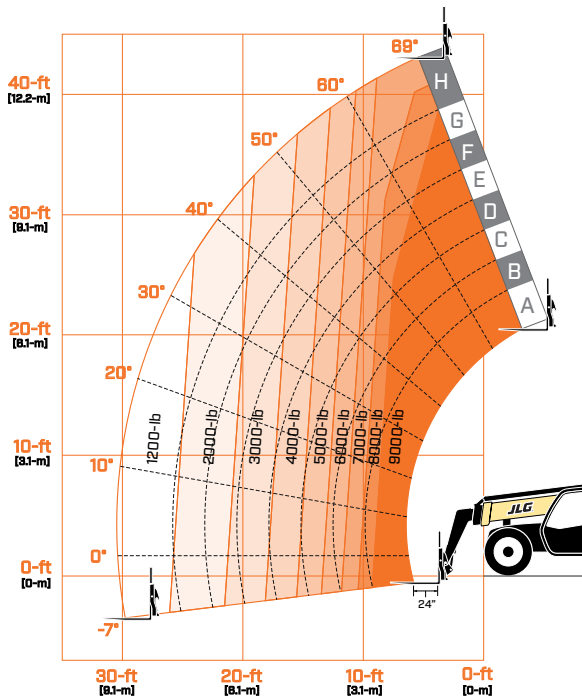

We provide coverage for one (1) full year on the entire machine, two (2) full years or 2,000 hours on the drivetrain and cover all specified major structural components for five (5) years. Due to continuous product improvements, we reserve the right to make specification and/or equipment changes without prior notification.



JLG INDUSTRIES, INC.
Toll-free US 877-JLG-LIFT
JLG.com

An Oshkosh Corporation Company