



An Oshkosh Corporation Company

Service and Maintenance Manual

Models X13SJP - X13SJN

31220629

January 17, 2025 - Rev B

CE

AS/NZS



An Oshkosh Corporation Company

INTRODUCTION - MAINTENANCE SAFETY PRECAUTIONS

GENERAL

This section contains the general safety precautions which must be observed during maintenance of the mobile elevating work platform (MEWP). It is of utmost importance that maintenance personnel pay strict attention to these warnings and precautions to avoid possible injury to themselves or others, or damage to the equipment. A maintenance program must be followed to ensure that the machine is safe to operate.

⚠ WARNING

MODIFICATION OR MAJOR ALTERATION OF A MACHINE SHALL BE MADE ONLY WITH THE PRIOR WRITTEN PERMISSION FROM THE MANUFACTURER. MODIFICATION IS DEFINED AS CHANGE(S) TO A MACHINE THAT AFFECT THE OPERATION, STABILITY, SAFETY FACTORS, RATED LOAD, OR SAFETY OF THE MACHINE IN ANY WAY.

The specific precautions to be observed during maintenance are inserted at the appropriate point in the manual. These precautions are, for the most part, those that apply when servicing hydraulic and larger machine component parts.

Your safety, and that of others, is the first consideration when engaging in the maintenance of equipment. Always be conscious of weight. Never attempt to move heavy parts without the aid of a mechanical device. Do not allow heavy objects to rest in an unstable position. When raising a portion of the equipment, ensure that adequate support is provided.

⚠ WARNING

SINCE THE MACHINE MANUFACTURER HAS NO DIRECT CONTROL OVER THE FIELD INSPECTION AND MAINTENANCE, SAFETY IN THIS AREA IS THE RESPONSIBILITY OF THE OWNER/OPERATOR.

HYDRAULIC SYSTEM SAFETY

It should be noted that the machines hydraulic systems operate at extremely high potentially dangerous pressures. Every effort should be made to relieve any system

pressure prior to disconnecting or removing any portion of the system.



MAINTENANCE

⚠ WARNING

FAILURE TO COMPLY WITH SAFETY PRECAUTIONS LISTED IN THIS SECTION COULD RESULT IN MACHINE DAMAGE, PERSONNEL INJURY OR DEATH AND IS A SAFETY VIOLATION.

- ENSURE REPLACEMENT PARTS OR COMPONENTS ARE IDENTICAL OR EQUIVALENT TO ORIGINAL PARTS OR COMPONENTS.
- NO SMOKING IS MANDATORY. NEVER REFUEL DURING ELECTRICAL STORMS. ENSURE THAT FUEL CAP IS CLOSED AND SECURE AT ALL OTHER TIMES.
- REMOVE ALL RINGS, WATCHES AND JEWELRY WHEN PERFORMING ANY MAINTENANCE.
- DO NOT WEAR LONG HAIR UNRESTRAINED, OR LOOSE-FITTING CLOTHING AND NECKTIES WHICH ARE APT TO BECOME CAUGHT ON OR ENTANGLED IN EQUIPMENT.
- OBSERVE AND OBEY ALL WARNINGS AND CAUTIONS ON MACHINE AND IN SERVICEMANUAL.
- KEEP OIL, GREASE, WATER, ETC. WIPED FROM STANDING SURFACES AND HAND HOLDS.
- USE CAUTION WHEN CHECKING A HOT, PRESSURIZED COOLANT SYSTEM.
- NEVER WORK UNDER AN ELEVATED BOOM UNTIL BOOM HAS BEEN SAFELY RESTRAINED FROM ANY MOVEMENT BY BLOCKING OR OVERHEAD SLING, OR BOOM SAFETY PROP HAS BEEN ENGAGED.
- BEFORE MAKING ADJUSTMENTS, LUBRICATING OR PERFORMING ANY OTHER MAINTENANCE, SHUT OFF ALL POWER CONTROLS.

INTRODUCTION - MAINTENANCE SAFETY PRECAUTIONS

- BATTERY SHOULD ALWAYS BE DISCONNECTED DURING REPLACEMENT OF ELECTRICAL COMPONENTS.
- KEEP ALL SUPPORT EQUIPMENT AND ATTACHMENTS STOWED IN THEIR PROPER PLACE.
- USE ONLY APPROVED, NONFLAMMABLE CLEANING SOLVENTS.

REVISION LOG

Original Issue	A - March 7, 2023
Revision	B - January 17, 2025

TABLE OF CONTENTS

SUBJECT - SECTION, PARAGRAPH		PAGE NO.
SECTION - INTRODUCTION - MAINTENANCE SAFETY PRECAUTIONS		
	GENERAL.....	1-A
	HYDRAULIC SYSTEM SAFETY.....	1-A
	MAINTENANCE.....	1-A
SECTION 1 - SPECIFICATIONS		
1.1	CAPACITIES	1-1
1.2	CAPACITIES TRACK SPECIFICATIONS	1-1
1.3	POWER SOURCE	1-2
1.4	SPECIFICATIONS AND PERFORMANCE DATA.....	1-3
	Reach Specifications	1-3
	Dimensional Data.....	1-3
	Function Speed Data.....	1-4
	Machine Orientation When Performing Speed Tests.....	1-5
1.5	HYDRAULIC PRESSURE SETTINGS - PSI (BAR).....	1-5
1.6	LUBRICATION	1-6
	Hydraulic Oil.....	1-6
1.7	SERIAL NUMBER LOCATION.....	1-8
1.8	FASTENER TORQUE CHARTS	1-9
SECTION 2 - GENERAL		
2.1	MACHINE PREPARATION, INSPECTION, AND MAINTENANCE	2-1
	General.....	2-1
	Preparation, Inspection, and Maintenance	2-1
	Pre-Start Inspection	2-1
	Pre-Delivery Inspection and Frequent Inspection.....	2-1
	Annual Machine Inspection	2-1
	Preventive Maintenance	2-1
2.2	SERVICE AND GUIDELINES	2-2
	General.....	2-2
	Safety and Workmanship.....	2-2
	Cleanliness	2-2
	Components Removal and Installation.....	2-2
	Component Disassembly and Reassembly	2-2
	Pressure-Fit Parts	2-2
	Bearings.....	2-3
	Gaskets.....	2-3
	Bolt Usage and Torque Application	2-3
	Hydraulic Lines and Electrical Wiring.....	2-3
	Hydraulic System	2-3
	Lubrication	2-3
	Battery	2-3
	Lubrication and Servicing	2-3
2.3	LUBRICATION AND INFORMATION	2-3
	Hydraulic System	2-3
	Hydraulic Oil.....	2-4
	Changing Hydraulic Oil.....	2-4
	Lubrication Specifications.....	2-4
2.4	CYLINDER DRIFT TEST	2-4
	Cylinder Drift	2-4
2.5	PINS AND COMPOSITE BEARING REPAIR GUIDELINES	2-5

TABLE OF CONTENTS

2.6 WELDING ON JLG EQUIPMENT 2-5
 Do the Following When Welding on JLG Equipment 2-5
 Do NOT Do the Following When Welding on JLG Equipment 2-5

SECTION 3 - CHASSIS & TURNTABLE

3.1 RUBBER TRACK MAINTENANCE/REPLACEMENT 3-1
 Checking Track Tension 3-1
 Tensioning Rubber Track 3-1
 Removing Rubber Track 3-1
 Installing Rubber Track 3-2
3.2 UNDERCARRIGE COMPONENTS 3-3
 Machine Positioning 3-3
 Replacement Roller Lower Wheel and Tracks Adjuster 3-3
 Disassembly 3-3
 Assembly 3-3
 Replacement Sprocket and Gear Motor 3-3
 Sprocket Removal 3-3
 Gear Motor Removal 3-3
 Gear Motor Installation 3-4
 Sprocket Installation 3-4
3.3 TRACKS EXTENSION REMOVAL 3-5
3.4 TRACK DRIVE 3-6
 Product Identification 3-6
3.5 SWING DRIVE (IMO) 3-7
 Technical Data – Type Plate 3-7
 Structure and Function 3-7
 Structure and Function 3-8
 Maintenance Tasks 3-8
 Lubricating The Slew Drive 3-9
3.6 POWER SYSTEM X13SJP - X13SJN 3-10
 Lithium Powered Units 3-10

SECTION 4 - BOOM & PLATFORM

4.1 BOOM MAINTENANCE 4-1
 Removal of the Boom Assembly 4-1
 Disassembly of the Main Boom 4-1
 Inspection 4-3
 Assembly of the Main Boom 4-3
 Installation of the Boom Assembly 4-4
4.2 WIRE ROPE AND PULLEYS 4-5
 Inspection 4-5
 Three Month Inspection 4-5
 Seven Year or 3000 Hours Replacement 4-5
4.3 ROPES TENSION ADJUSTMENT PROCEDURE 4-6
4.4 PROXIMITY SENSOR ADJUSTMENT 4-8
4.5 PLATFORM REMOVAL/INSTALLATION 4-8
 Removal 4-8
 Installation 4-9
4.6 SKYGUARD INSTALLATION - ONE PERSON PLATFORM 4-10
 Options/Accessories Prohibited When Installing This Kit 4-10
 Tools & Equipment Required: 4-10
 Personnel Required: 4-10
 Parts List: 4-10
 Installation: 4-12
 SkyGuard System 4-15

SECTION 5 - HYDRAULICS

5.1	GENERAL.....	5-1
5.2	CHASSIS HYDRAULIC SYSTEM.....	5-2
	Outriggers.....	5-4
	Tracks Widening.....	5-5
5.3	BOOM, PLATFORM & TURNTABLE HYDRAULIC SYSTEM.....	5-6
5.4	CYLINDER REPAIR.....	5-10
	Specification - Cylinders Overview.....	5-10
	Hydraulic Cylinders Torque Specifications.....	5-14
	Cylinder Assembling.....	5-15
	Cylinder Repair Without Sensor.....	5-15
	Piston With Nut Disassembling.....	5-16
	Cylinder Assembly.....	5-16
	Seals Head Replacing.....	5-17
	Cylinder Inspection.....	5-17
	Bushes Replacement.....	5-18
	Emptying Of The Cylinder.....	5-19
5.5	REPLACEMENT HYDRAULIC PUMP.....	5-19
	Pump Removal.....	5-19
	Pump Installation.....	5-19
5.6	HYDRAULIC DIAGRAM.....	5-20

SECTION 6 - JLG CONTROL SYSTEM

6.1	INTRODUCTION.....	6-1
6.2	PLATFORM - REMOTE CONTROL STATION.....	6-2
	LCD Display Screen.....	6-3
	LCD Display Icon Description.....	6-5
	Only Lithium Icons.....	6-6
6.3	DIAGNOSTIC BY SERVICE MENU.....	6-6
	Menu Input.....	6-7
	Only Lithium Input.....	6-10
	Language Menu.....	6-11
	Error Menu.....	6-11
	Working Hours Menu.....	6-13
	Joystick Menu.....	6-13
6.4	MACHINE SETUP MENU.....	6-14
	Setup - Version.....	6-15
	Setup - Time.....	6-15
	Setup - Password.....	6-15
	Setup - Date.....	6-15
	Setup - Load Cell Board (ECM3) Calibration.....	6-16
	Setup - Acceler (Calibrating Tilt Sensor).....	6-16
	Setup - Extra.....	6-17
6.5	MASTER BOARD (ECM1) REPLACEMENT AND SETTING.....	6-21
	New Master Board.....	6-21
	Already Initialized Master Board.....	6-22
	Software Recovery By Modem.....	6-23
6.6	CODE MENU.....	6-23

SECTION 7 - GENERAL ELECTRICAL INFORMATION & SCHEMATICS

7.1	GENERAL.....	7-1
7.2	MULTIMETER BASICS.....	7-1
	Grounding.....	7-1
	Backprobing.....	7-1
	Min/Max.....	7-1

TABLE OF CONTENTS

	Polarity.....	7-1
	Scale	7-1
	Voltage Measurement	7-2
	Resistance Measurement.....	7-2
	Continuity Measurement.....	7-3
	Current Measurement.....	7-3
	Continuity Measurement Over Long Distances.....	7-4
	Requirements:.....	7-4
	Procedure	7-4
7.3	ELECTRICAL SCHEMATICS MANUALS.....	7-4

SECTION 1. SPECIFICATIONS

1.1 CAPACITIES

Table 1-1. Hydraulic & Fuel Tank Capacities

MACHINE	HYDRAULIC OIL TANK CAPACITY	GASOLINE	DIESEL
X13SJP / X13SJM	24 L (6.34 gal)	5,3 L (1.40 gal)	5 L (1.3 gal)

1.2 CAPACITIES TRACK SPECIFICATIONS

Table 1-2. Track Specifications

MACHINE	RUBBER BELT TRACK			
	TYPE	PART NUMBER	DIMENSIONS	DRAWING
X13SJP / X13SJM	LOW PROFILE BLACK COLOR	053715L0	Cm 180 X 37 X 72	
	LOW PROFILE NON-MARKING	053715LB		

Table 1-3. Ground Bearing Pressure

PRESSURES AND REACTIONS TO THE GROUND ON OUTRIGGER				
MODEL	Maximum Ground Bearing Pressure On Each Pad [daN] - [lbf]		Maximum Ground Bearing Pressure [daN/cm ²] - [PSI]	
X13SJP / X13SJM	1670 daN	3754 lbf	2,36 daN/cm ²	34,2 PSI

1.3 POWER SOURCE

Table 1-4. Power Configurations

	X13SJP / X13SJN
Lithium	80 Ah 48 V
AC Electric Motor	110V 50 Hz (2,2 kW) 120V 60 Hz (1,2 kW) 230V 50 Hz (2,2 kW) 230V 60 Hz (2,2 kW)

1.4 SPECIFICATIONS AND PERFORMANCE DATA

Reach Specifications

Table 1-5. Machine Reach Specifications

	X13SJP	X13SJM
Max. working Height (inclusive operator)	13,30 m	13,30 m
Max. Height (platform floor)	10,8 m	10,8 m
Max working Horizontal Outreach	5,8 m	5,8 m
Up & Over Height	6,4 m	6,4 m
Swing (non - continuous)	360°	360°
Max slope allowed in travel direction	16° / 28,7%	16° / 28,7%
Max stabilization slope	11°	14°
Max Approach angles (Front/Rear)	29.5°/18°	29°/18°

Dimensional Data

Table 1-6. Machine Dimensional Data

	X13SJP	X13SJM
Platform size (standard 2 persons)	1305 X 690 mm	1305 X 690 mm
Stowed width (with std. 2P platform)	1305 mm	1305 mm
Stowed width (without platform)	748/1106 mm	748/1106 mm
Stowed height (on tracks)	1984 mm	1948 mm
Stowed length	4316 mm	4316 mm
Outrigger footprint (Disc Center)	3053 mm X 2679 mm	2770 mm X 2318 mm
Outrigger footprint reduced stabilization area (Disc Center)	NA	NA
Gross machine weight	2060 Kg	1938 Kg

Function Speed Data

Table 1-7. X13SJP / X13SJM Function Speeds

*FUNCTION	POWER SYSTEM	
	Engine	Lithium
TELESCOPE EXTEND	12" - 17"	23" - 32"
TELESCOPE RETRACT	12" - 17"	23" - 32"
TOWER BOOM UP	16" - 23"	16" - 23"
TOWER BOOM DOWN	20" - 28"	24" - 34"
UPPER BOOM UP	21" - 28"	27" - 37"
UPPER BOOM DOWN	22" - 30"	26" - 36"
PLATFORM ‡ ROTATE RIGHT	7" - 15"	7" - 30"
PLATFORM ‡ ROTATE LEFT	7" - 15"	7" - 30"
SWING LEFT	38" - 48"	45" - 55"
SWING RIGHT	38" - 48"	45" - 55"
JIB UP	7" - 15"	15" - 25"
JIB DOWN	7" - 15"	10" - 20"
PLATFORM ‡ LEVEL UP	33" - 55"	33" - 55"
PLATFORM ‡ LEVEL DOWN	37" - 50"	37" - 50"
MAX DRIVE SPEED (with auto two speed)	0.87/1.62 mph (1,4/2,6 Km/h)	0.24/0.50/0.99 mph (0,4/0,8/1,6 Km/h)
*Units of time in seconds		
‡ Or "Basket"		

Table 1-8. X13SJP / X13SJM Movement Speeds

MOVEMENT	JOYSTICK	T. Lim.	*Tempo [Time]
SFL OUT	J4 UP	11	12" - 17"
SFL IN	J4 DW	11	12" - 17"
1E2 UP	J2 UP	10	15" - 23"
1E2 DW	J2 DW	10	15" - 23"
3E4 UP	J3 UP	20	21" - 28"
3E4 DW	J3 DW	20	22" - 30"
RT AE UP (1/2 CYCLE)	J7 UP	30	38" - 48"
RT AE DW (1/2 CYCLE)	J7 DW	30	38" - 48"
JIB UP	J6 UP	5,5	7" - 15"
JIB DW	J6 DW	5,5	7" - 15"
LIV UP	J9 UP	-	33" - 55"
LIV DW	J9 DW	-	37" - 50"
*Units of time in seconds			

Machine Orientation When Performing Speed Tests

- **Lift:** Boom Retracted. Telescope Retracted. Lift Up, Record Time, Lift Down, Record Time.
- **Swing:** Machine stabilized, upper Boom at Full Elevation. Telescope Retracted. Swing the Turntable (Turret) to the end stop. Swing the Opposite Direction, Record Time.
- **Telescope:** Boom at Full Elevation; Telescope Retracted; Telescope Out, Record Time. Telescope In, Record Time.
- **Drive:** Test to be done on a smooth level surface. Drive Select Switch should be set at 2WD High Engine. Start approximately 25 ft. (7.62 m) from starting point so that the unit is at maximum speed when starting the test.

- **Platform Rotate:** Platform level and completely rotated one direction. Rotate the opposite direction, Record Time. Rotate the other direction, Record Time.
- **Articulating Jib:** Platform level and centered with the boom. Start with the Jib down. Jib Up, Record Time. Jib Down, Record Time.
- **Lower Lift:** Upper Boom horizontal. Telescoped In. Lower Lift Up, Record Time. Lower Lift Down, Record Time.

Test Notes:

1. Stop watch should be started with the function, not with the controller or switch.
2. All speed tests are run from ground with remote control connected on the platform.
3. Function speeds may vary due to cold, thick

1.5 HYDRAULIC PRESSURE SETTINGS - PSI (BAR)

Table 1-9. Pressure Settings

MODEL	UNDERCARRIAGE Left and Right Control Valve		TOWER Control Valve	
	BAR	PSI	BAR	PSI
X13SJP, X13SJN	180	2610	165	2393

Table 1-10. Reductions Drive Speed Pressure Setting

MODEL	AUTOMATIC REDUCTIONS DRIVE SPEED	
	BAR	PSI
X13SJP, X13SJN	30	427

1.6 LUBRICATION

Hydraulic Oil

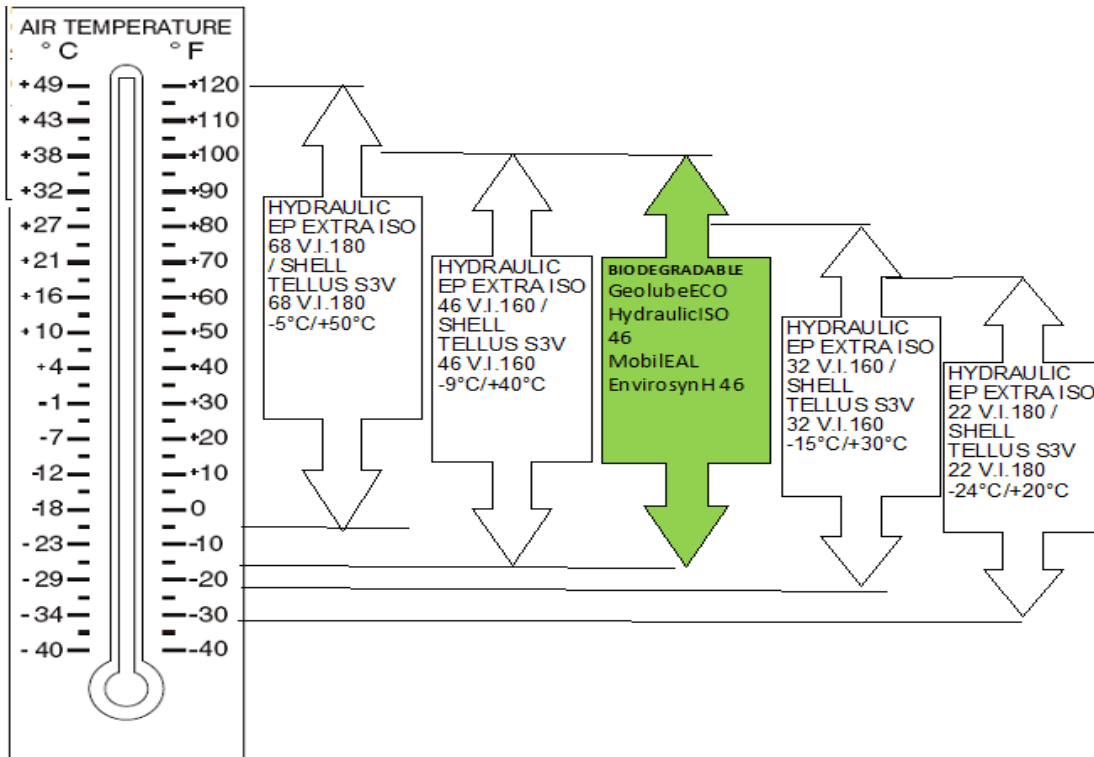

Figure 1-1. Hydraulic Oil Temperature Operating Range

FLUID	PROPERTIES		TYPE				CLASSIFICATIONS		
DESCRIPTION	Viscosity at 40°C (cst, Typical)	Viscosity Index	Mineral Oils	Vegetable Oils	Synthetic	Synthetic Polyol Esters	Readily Biodegradable*	Virtually Non-toxic**	Fire Resistant***
Pakelo Hydraulic EP Extra ISO 68	68	180	X						
Pakelo Hydraulic EP Extra ISO 46	46	160	X						
GeolubeECO Hydraulic ISO 46 (P/N 17527700)	47.3	144				X	X		
Pakelo Hydraulic EP Extra ISO 32	32	160	X						
Pakelo Hydraulic EP Extra ISO 22	22	180	X						
SHELL TELLUS S3V 68	68	180	X						
SHELL TELLUS S3V 46	46	160	X						
MobilEAL EnviroSynH46 (P/N2300029)						X	X		
SHELL TELLUS S3V 32	32	160	X						
SHELL TELLUS S3V 22	22	180	X						

Table 1-11. Hydraulic Oil Specifications

* Readily biodegradable classification indicates one of the following: CO2 Conversion > 60% per EPA 560/6-82-003 / CO2 Conversion > 80% per CEC-L-33-A-93.

** Virtually Non-toxic classification indicates an LC50 > 5000 per OECD 203.

*** Fire Resistant classification indicates Factory Mutual Research Corp. (FMRC) Approval

Flash point (C.O.C) for 68-46-32-22: 210°C.

1.7 SERIAL NUMBER LOCATION

The serial number plate is fastening onto the frame on fork lifting pockets on X135JP/X135JN.

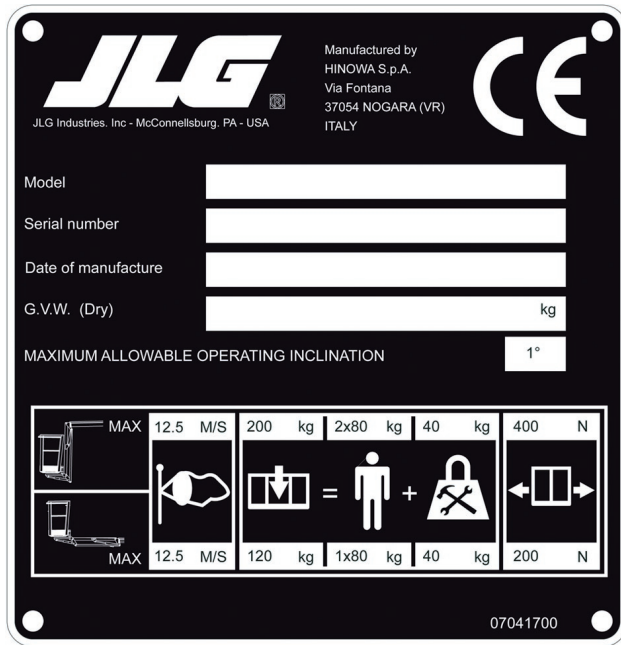

Figure 1-2. Serial Number Plate



Figure 1-3. Serial Number Plate Location

Values for Magni Coating Fasteners (Ref 4150701)														
Size	TPI	Bolt Dia	Tensile Stress Area	Clamp Load	SAE GRADE 5 BOLTS & GRADE 2 NUTS				SAE GRADE 8 (HEX HD) BOLTS & GRADE 8 NUTS*					
					Torque (Dry) K=0.17	Torque (Locite@ 242™ or 271™ OR Vibra-TITE™ 111 or 140) K=0.16	Torque (Locite@ 262™ or VIBRA-TITE™ 131) K=0.15	Clamp Load	Torque (Dry or Locite@263) K=0.17	Torque (Locite@242™ or 271™ OR Vibra-TITE™ 111 or 140) K=0.16	Torque (Locite@ 262™ or VIBRA-TITE™ 131) K=0.15			
		In	Sq In	LB	IN-LB	FT-LB	IN-LB	FT-LB	IN-LB	FT-LB	IN-LB	FT-LB	IN-LB	FT-LB
4	40	0.1120	0.00604	380	7	0.8								
	48	0.1120	0.00661	420	8	0.9								
6	32	0.1380	0.00909	580	14	1.5								
	40	0.1380	0.01015	610	14	1.6								
8	32	0.1640	0.01400	900	25	2.8								
	36	0.1640	0.01474	940	26	2.9								
10	24	0.1900	0.01750	1120	36	4.1								
	32	0.1900	0.02000	1285	42	4.7								
1/4	20	0.2500	0.0318	2020	86	9.7	80	9			114	13		
	28	0.2500	0.0364	2320	99	11.1	95	11			131	15		
		In	Sq In	LB	FT-LB	IN-LB	FT-LB	IN-LB	FT-LB	IN-LB	FT-LB	IN-LB	FT-LB	IN-LB
5/16	18	0.3125	0.0624	3340	15	20	14	19	15	20	20	25	20	25
	24	0.3125	0.0680	3700	15	20	15	21	15	20	25	20	25	25
3/8	16	0.3750	0.0775	4940	25	35	25	34	25	34	35	50	35	50
	24	0.3750	0.0878	5600	30	40	28	38	25	34	40	55	35	50
7/16	14	0.4375	0.1063	6800	40	55	40	54	35	48	60	80	50	70
	20	0.4375	0.1187	7550	45	60	44	60	40	54	65	90	60	80
1/2	13	0.5000	0.1419	9050	65	90	60	82	55	75	127	115	80	110
	20	0.5000	0.1599	10700	75	100	71	97	65	88	144	100	90	120
9/16	12	0.5625	0.1820	11600	90	120	87	118	80	109	164	130	125	170
	18	0.5625	0.2030	12950	105	145	97	132	90	122	182	145	135	185
5/8	11	0.6250	0.2260	14400	130	175	120	163	115	156	203	180	245	170
	18	0.6250	0.2560	16300	145	195	136	185	125	170	230	205	280	260
3/4	10	0.7500	0.3340	21300	225	305	213	290	200	272	301	300	410	380
	16	0.7500	0.3730	23800	255	345	238	324	225	306	355	335	455	430
7/8	9	0.8750	0.4620	29400	365	495	343	466	320	435	416	515	700	660
	14	0.8750	0.5090	32400	400	545	378	514	355	483	458	570	775	730
1	8	1.0000	0.6060	38600	545	740	515	700	480	663	515	730	995	930
	12	1.0000	0.6630	42200	600	815	563	765	530	721	597	845	1150	1080
1 1/8	7	1.1250	0.7630	42300	675	920	635	863	595	809	687	1095	1490	1400
	12	1.1250	0.8560	47500	755	1025	713	969	670	911	770	1225	1665	1570
1 1/4	7	1.2500	0.9690	53800	955	1300	897	1219	840	1142	872	1545	2100	1980
	12	1.2500	1.0730	59600	1055	1435	993	1351	930	1265	966	1710	2325	2190
1 3/8	6	1.3750	1.1550	64100	1250	1700	1175	1598	1100	1496	1040	2025	2755	2590
	12	1.3750	1.3150	73000	1420	1930	1338	1820	1255	1707	1181	2300	3130	2945
1 1/2	6	1.5000	1.4050	78000	1660	2260	1560	2122	1465	1992	1265	2690	3660	3440
	12	1.5000	1.5800	87700	1865	2535	1754	2385	1645	2237	1422	3020	4105	3870

NO. 500059 REV. K

- NOTES:
1. THESE TORQUE VALUES DO NOT APPLY TO CADMIUM PLATED FASTENERS
 2. ALL TORQUE VALUES ARE STATIC TORQUE MEASURED PER STANDARD AUDIT METHODS TOLERANCE = ±10%
 3. * ASSEMBLY USES HARDENED WASHER

Figure 1-5. Torque Chart - Sheet 2 of 5 - (SAE Fasteners)

Size		TPI	Bolt Dia	Tensile Stress Area	Magni Coating (Ref 4150701)*				Zinc Yellow Chromate Fasteners (Ref 4150707)*							
					Clamp Load See Note 4	Torque (Dry) K = .17	Torque (Loctite® 242™ or 271™ OR Vibra-TITE™ 111 or 140 OR Precoat 85®) K=0.15	Torque (Loctite® 262™ or Vibra-TITE™ 131) K=0.15	Clamp Load See Note 4	Torque (Dry) K = .20	Torque (Loctite® 242™ or 271™ OR Vibra-TITE™ 111 or 140 OR Precoat 85®) K=0.15	Torque (Loctite® 262™ or Vibra-TITE™ 131) K=0.15				
		In	Sq In	LB	IN-LB	[N.m]	FT-LB	[N.m]	IN-LB	[N.m]	FT-LB	[N.m]	IN-LB	[N.m]	FT-LB	[N.m]
4	40	0.1120	0.00604													
	48	0.1120	0.00661													
6	32	0.1380	0.00909													
	40	0.1380	0.01015													
8	32	0.1640	0.01400													
	36	0.1640	0.01474													
10	24	0.1900	0.01750													
	32	0.1900	0.02000													
1/4	20	0.2500	0.0318	2860	122	14	114	13	2860	143	16	129	15			
	28	0.2500	0.0364	3280	139	16	131	15	3280	164	19	148	17			
5/16	18	0.3125	0.0524	4720	20	25	20	25	4720	25	35	20	25	20	25	25
	24	0.3125	0.0580	5220	25	35	20	25	5220	25	35	25	35	20	25	25
3/8	16	0.3750	0.0775	7000	35	50	35	50	7000	45	60	40	55	35	50	50
	24	0.3750	0.0878	7900	40	55	40	55	7900	50	70	45	60	35	50	50
7/16	14	0.4375	0.1063	9580	60	80	55	70	9580	70	95	65	90	50	70	70
	20	0.4375	0.1187	10700	65	90	60	80	10700	80	110	70	95	60	80	80
1/2	13	0.5000	0.1419	12750	90	120	85	115	12750	105	145	95	130	90	120	120
	20	0.5000	0.1599	14400	100	135	95	130	14400	120	165	110	150	100	130	130
9/16	12	0.5625	0.1820	16400	130	175	125	170	16400	155	210	140	190	115	155	155
	18	0.5625	0.2030	18250	145	195	135	185	18250	170	230	155	210	130	175	175
5/8	11	0.6250	0.2260	20350	180	245	170	230	20350	210	285	190	260	160	220	220
	18	0.6250	0.2560	23000	205	280	190	260	23000	240	325	215	290	180	245	245
3/4	10	0.7500	0.3340	30100	320	435	300	300	30100	375	510	340	460	280	380	380
	16	0.7500	0.3730	33600	355	485	335	455	33600	420	570	380	515	315	430	430
7/8	9	0.8750	0.4620	41600	515	700	485	660	41600	605	825	545	740	455	620	620
	14	0.8750	0.5090	45800	570	775	535	730	45800	670	910	600	815	500	680	680
1	8	1.0000	0.6060	51500	730	995	695	930	51500	860	1170	775	1055	645	875	875
	12	1.0000	0.6630	59700	845	1150	795	1080	59700	995	1355	895	1215	745	1015	1015
1 1/8	7	1.1250	0.7630	68700	1095	1490	1030	1400	68700	1290	1755	1160	1580	965	1310	1310
	12	1.1250	0.8560	77000	1225	1665	1155	1570	77000	1445	1965	1300	1770	1085	1475	1475
1 1/4	7	1.2500	0.9690	87200	1545	2100	1455	1980	87200	1815	2470	1635	2225	1365	1855	1855
	12	1.2500	1.0730	96600	1710	2325	1610	2190	96600	2015	2740	1810	2460	1510	2055	2055
1 3/8	6	1.3750	1.1550	104000	2025	2755	1905	2590	104000	2385	3245	2145	2915	1785	2430	2430
	12	1.3750	1.3150	118100	2300	3130	2165	2945	118100	2760	3680	2435	3310	2030	2760	2760
1 1/2	6	1.5000	1.4050	126500	2690	3660	2530	3440	126500	3165	4305	2845	3870	2370	3225	3225
	12	1.5000	1.5800	142200	3020	4105	2845	3870	142200	3555	4835	3200	4350	2665	3625	3625

NO. 5000U59 REV. K

NOTES: 1. THESE TORQUE VALUES DO NOT APPLY TO CADMIUM PLATED FASTENERS
 2. ALL TORQUE VALUES ARE STATIC TORQUE MEASURED PER STANDARD AUDIT METHODS TOLERANCE = ±10%
 *3. ASSEMBLY USES HARDENED WASHER OR FASTENER IS PLACED AGAINST PLATED STEEL OR RAW ALUMINUM
 4. CLAMP LOAD LISTED FOR SHCS IS SAME AS GRADE 8 OR CLASS 10.9 AND DOES NOT REPRESENT FULL STRENGTH CAPABILITY OF SHCS. IF HIGHER LOAD IS REQUIRED, ADDITIONAL TESTING IS REQUIRED.

Figure 1-6. Torque Chart - Sheet 3 of 5 - (SAE Fasteners)

Values for Zinc Yellow Chromate Fasteners (Ref 4150707)											
CLASS 8.8 METRIC (HEX/SOCKET HEAD) BOLTS CLASS 8 METRIC NUTS					CLASS 10.9 METRIC (HEX HEAD) BOLTS CLASS 10 METRIC NUTS CLASS 12.9 SOCKET HEAD CAP SCREWS M3 - M5*						
Size	PITCH	Tensile Stress Area	Clamp Load	Torque (Dry or Loctite® 263™)	Torque (Lub)	Torque (Loctite® 262™ OR Vibra-TITE™ 131)	Torque (Loctite® 242™ or 271™ OR Vibra-TITE™ 111 or 140)	Clamp Load	Torque (Dry or Loctite® 263™) K = 0.20	Torque (Lub OR Loctite® 242™ or 271™ OR Vibra-TITE™ 111 or 140) K = 0.18	Torque (Loctite® 262™ OR Vibra-TITE™ 131) K = 0.15
		Sq.mm	KN	[N.m]	[N.m]	[N.m]	[N.m]	KN	[N.m]	[N.m]	[N.m]
3	0.5	5.03	2.19	1.3	1.0	1.2	1.4	3.13			
3.5	0.6	6.78	2.95	2.1	1.6	1.9	2.3	4.22			
4	0.7	8.78	3.82	3.1	2.3	2.8	3.4	5.47			
5	0.8	14.20	6.18	6.2	4.6	5.6	6.8	8.85			
6	1	20.10	8.74	11	7.9	9.4	12	12.5			
7	1	28.90	12.6	18	13	16	19	18.0	25	23	19
8	1.25	36.60	15.9	26	19	23	28	22.8	37	33	27
10	1.5	58.00	25.2	50	38	45	55	36.1	70	65	55
12	1.75	84.30	36.7	88	66	79	97	52.5	125	115	95
14	2	115	50.0	140	105	126	154	71.6	200	180	150
16	2	157	68.3	219	164	197	241	97.8	315	280	235
18	2.5	192	83.5	301	226	271	331	119.5	430	385	325
20	2.5	245	106.5	426	320	383	469	152.5	610	550	460
22	2.5	303	132.0	581	436	523	639	189.0	830	750	625
24	3	353	153.5	737	553	663	811	222.0	1085	960	800
27	3	459	199.5	1080	810	970	1130	286.0	1545	1390	1160
30	3.5	561	244.0	1460	1100	1320	1530	349.5	2095	1885	1575
33	3.5	694	302.0	1990	1490	1790	2090	432.5	2855	2570	2140
36	4	817	355.5	2560	1920	2300	2690	509.0	3665	3300	2750
42	4.5	1120	487.0	4090	3070	3680	4290	698.0	5865	5275	4395

NO. 500059 REV. K

- NOTES: 1. THESE TORQUE VALUES DO NOT APPLY TO CADMIUM PLATED FASTENERS
 2. ALL TORQUE VALUES ARE STATIC TORQUE MEASURED PER STANDARD AUDIT METHODS TOLERANCE = ±10%
 *3. ASSEMBLY USES HARDENED WASHER OR FASTENER IS PLACED AGAINST PLATED STEEL OR RAW ALUMINUM
 4. CLAMP LOAD LISTED FOR SHCS IS SAME AS GRADE 8 OR CLASS 10.9 AND DOES NOT REPRESENT FULL STRENGTH CAPABILITY OF SHCS. IF HIGHER LOAD IS REQUIRED, ADDITIONAL TESTING IS REQUIRED.

Figure 1-7. Torque Chart - Sheet 4 of 5 - (METRIC Fasteners)

Values for Magni Coated Fasteners (Ref 4150701)										
CLASS 8.8 METRIC (HEX/SOCKET HEAD) BOLTS CLASS 8 METRIC NUTS					CLASS 10.9 METRIC (HEX HEAD) BOLTS CLASS 10 METRIC NUTS CLASS 12.9 SOCKET HEAD CAP SCREWS M6 AND ABOVE*					
Size	PITCH	Tensile Stress Area	Clamp Load	Torque (Dry or Loctite® 263™) K=0.17	Torque (Loctite® 262™ OR Vibra-TITE™ 131) K=0.16	Torque (Loctite® 242™ or 271™ OR Vibra-TITE™ 111 or 140) K=0.15	Clamp Load	Torque (Dry or Loctite® 263™) K = 0.17	Torque (Lub OR Loctite® 242™ or 271™ OR Vibra-TITE™ 111 or 140) K = 0.16	Torque (Loctite® 262™ OR Vibra-TITE™ 131) K=0.15
		Sq mm	KN	[N.m]	[N.m]	[N.m]	KN	[N.m]	[N.m]	[N.m]
3	0.5	5.03	2.19	1.1	1.1	1.0	3.13			
3.5	0.6	6.78	2.95	1.8	1.7	1.5	4.22			
4	0.7	8.78	3.82	2.6	2.4	2.3	5.47			
5	0.8	14.20	6.18	5.3	4.9	4.6	8.85			
6	1	20.10	8.74	9	8.4	7.9	12.5	13	12	11
7	1	28.90	12.6	15	14	13	18.0	21	20	19
8	1.25	36.60	15.9	22	20	19	22.8	31	29	27
10	1.5	58.00	25.2	43	40	38	36.1	61	58	55
12	1.75	84.30	36.7	75	70	66	52.5	105	100	95
14	2	115	50.0	119	110	105	71.6	170	160	150
16	2	157	68.3	186	175	165	97.8	265	250	235
18	2.5	192	83.5	256	240	225	119.5	365	345	325
20	2.5	245	106.5	362	340	320	152.5	520	490	460
22	2.5	303	132.0	494	465	435	189.0	705	665	625
24	3	353	153.5	627	590	555	222.0	905	850	800
27	3	459	199.5	916	860	810	286.0	1315	1235	1160
30	3.5	561	244.0	1245	1170	1100	349.5	1780	1680	1575
33	3.5	694	302.0	1694	1595	1495	432.5	2425	2285	2140
36	4	817	355.5	2176	2050	1920	509.0	3115	2930	2750
42	4.5	1120	487.0	3477	3275	3070	698.0	4985	4690	4395

NOTES: 1. THESE TORQUE VALUES DO NOT APPLY TO CADMIUM PLATED FASTENERS

2. ALL TORQUE VALUES ARE STATIC TORQUE MEASURED PER STANDARD AUDIT METHODS TOLERANCE = ±10%

*3. ASSEMBLY USES HARDENED WASHER OR FASTENER IS PLACED AGAINST PLATED STEEL OR RAW ALUMINUM

4. CLAMP LOAD LISTED FOR SHCS IS SAME AS GRADE 8 OR CLASS 10.9 AND DOES NOT REPRESENT FULL STRENGTH CAPABILITY OF SHCS. IF HIGHER LOAD IS REQUIRED, ADDITIONAL TESTING IS REQUIRED.

NO. 500059 REV. K

Figure 1-8. Torque Chart - Sheet 5 of 5 - (METRIC Fasteners)

SECTION 2. GENERAL

2.1 MACHINE PREPARATION, INSPECTION, AND MAINTENANCE

General

This section provides the necessary information needed by those personnel that are responsible to place the machine in operation readiness and maintain its safe operating condition. For maximum service life and safe operation, ensure that all the necessary inspections and maintenance have been completed before placing the machine into service. With proper care, maintenance and inspections performed per JLG's recommendations with any and all discrepancies corrected, this product will be fit for continued use.

Preparation, Inspection, and Maintenance

It is important to establish and conform to a comprehensive inspection and preventive maintenance program. The following table outlines the periodic machine inspections and maintenance recommended by JLG Industries, Inc. Consult your national, regional, or local regulations for further requirements for mobile elevating work platforms (MEWPs). The frequency of inspections and maintenance must be increased as environment, severity and frequency of usage requires.

Pre-Start Inspection

It is the User's or Operator's primary responsibility to perform a Pre-Start Inspection of the machine prior to use daily or at each change of operator. Reference the Operator's and Safety Manual for completion procedures for the Pre-Start Inspection. The Operator and Safety Manual must be read in its entirety and understood prior to performing the Pre-Start Inspection.

Pre-Delivery Inspection and Frequent Inspection

The Pre-Delivery Inspection and Frequent Inspection shall be performed by a qualified JLG equipment mechanic. JLG Industries, Inc. recognizes a qualified JLG equipment mechanic as a person who, by possession of a recognized degree, certificate, extensive knowledge, training, or experience, has successfully demonstrated the ability and proficiency to service, repair, and maintain the subject JLG product model.

The Pre-Delivery Inspection and Frequent Inspection procedures are performed in the same manner, but at different times. The Pre-Delivery Inspection shall be performed prior to each sale, lease, or rental delivery. The Frequent Inspection shall be accomplished for each machine in service for 3 months or 150 hours (whichever comes first); out of service for a period of more than 3 months; or when purchased used. The frequency of

this inspection must be increased as environment, severity and frequency of usage requires.

Reference the JLG Pre-Delivery and Frequent Inspection Form and the Inspection and Preventive Maintenance Schedule for items requiring inspection during the performance of these inspections. Reference the appropriate areas of this manual for servicing and maintenance procedures.

Annual Machine Inspection

The Annual Machine Inspection must be performed on an annual basis, no later than thirteen (13) months from the date of the prior Annual Machine Inspection. JLG Industries recommends this task be performed by a Factory-Trained Service Technician. JLG Industries, Inc. recognizes a Factory-Trained Service Technician as a person who has successfully completed the JLG Service Training School for the subject JLG product model. Reference the machine Service and Maintenance Manual and appropriate JLG inspection form for performance of this inspection.

Reference the JLG Annual Machine Inspection Form and the Inspection and Preventive Maintenance Schedule for items requiring inspection during the performance of this inspection. Reference the appropriate areas of this manual for servicing and maintenance procedures.

For the purpose of receiving safety-related bulletins, it is important that JLG Industries, Inc. has updated ownership information for each machine. When performing each Annual Machine Inspection, notify JLG Industries, Inc. of the current machine ownership.

Preventive Maintenance

In conjunction with the specified inspections, maintenance shall be performed by a qualified JLG equipment mechanic. JLG Industries, Inc. recognizes a qualified JLG equipment mechanic as a person who, by possession of a recognized degree, certificate, extensive knowledge, training, or experience, has successfully demonstrated the ability and proficiency to service, repair, and maintain the subject JLG product model.

Reference the Preventive Maintenance Schedule and the appropriate areas of this manual for servicing and maintenance procedures. The frequency of service and maintenance must be increased as environment, severity and frequency of usage requires.

Table 2-1. Inspection and Maintenance

TYPE	FREQUENCY	PRIMARY RESPONSIBILITY	SERVICE QUALIFICATION	REFERENCE
Pre-Start Inspection	Prior to use each day; or At each Operator change.	User or Operator	User or Operator	Operator and Safety Manual
Pre-Delivery Inspection	Prior to each sale, lease, or rental delivery.	Owner, Dealer, or User	Qualified JLG Mechanic	Service and Maintenance Manual and applicable JLG inspection form.
Frequent Inspection	In service for 3 months or 150 hours, whichever comes first; or Out of service for a period of more than 3 months; or Purchased used.	Owner, Dealer, or User	Qualified JLG Mechanic	Service and Maintenance Manual and applicable JLG inspection form.
Annual Machine Inspection	Annually, no later than 13 months from the date of the prior inspection.	Owner, Dealer, or User	Factory-Trained Service Technician (Recommended)	Service and Maintenance Manual and applicable JLG inspection form.
Preventive Maintenance	At intervals as specified in the Service and Maintenance Manual.	Owner, Dealer, or User	Qualified JLG Mechanic	Service and Maintenance Manual

2.2 SERVICE AND GUIDELINES

General

The following information is provided to assist you in the use and application of servicing and maintenance procedures contained in this book.

Safety and Workmanship

Your safety, and that of others, is the first consideration when engaging in the maintenance of equipment. Always be conscious of weight. Never attempt to move heavy parts without the aid of a mechanical device. Do not allow heavy objects to rest in an unstable position. When raising a portion of the equipment, ensure that adequate support is provided.

Cleanliness

1. The most important single item in preserving the long service life of a machine is to keep dirt and foreign materials out of the vital components. Precautions have been taken to safeguard against this. Shields, covers, seals, and filters are provided to keep air, fuel, and oil supplies clean; however, these items must be maintained on a scheduled basis in order to function properly.
2. At any time when air, fuel, or oil lines are disconnected, clear adjacent areas as well as the openings and fittings themselves. As soon as a line or component is disconnected, cap or cover all openings to prevent entry of foreign matter.

3. Clean and inspect all parts during servicing or maintenance, and assure that all passages and openings are unobstructed. Cover all parts to keep them clean. Be sure all parts are clean before they are installed. New parts should remain in their containers until they are ready to be used.

Components Removal and Installation

1. Use adjustable lifting devices, whenever possible, if mechanical assistance is required. All slings (chains, cables, etc.) should be parallel to each other and as near perpendicular as possible to top of part being lifted.
2. Should it be necessary to remove a component on an angle, keep in mind that the capacity of an eye-bolt or similar bracket lessens, as the angle between the supporting structure and the component becomes less than 90 degrees.
3. If a part resists removal, check to see whether all nuts, bolts, cables, brackets, wiring, etc., have been removed and that no adjacent parts are interfering.

Component Disassembly and Reassembly

When disassembling or reassembling a component, complete the procedural steps in sequence. Do not partially disassemble or assemble one part, then start on another. Always recheck your work to assure that nothing has been overlooked. Do not make any adjustments, other than those recommended, without obtaining proper approval.

Pressure-Fit Parts

When assembling pressure-fit parts, use an anti-seize or molybdenum disulphide base compound to lubricate the mating surface.

Bearings

1. When a bearing is removed, cover it to keep out dirt and abrasives. Clean bearings in nonflammable cleaning solvent and allow to drip dry. Compressed air can be used but do not spin the bearing.
2. Discard bearings if the races and balls (or rollers) are pitted, scored, or burned.
3. If bearing is found to be serviceable, apply a light coat of oil and wrap it in clean (waxed) paper. Do not unwrap reusable or new bearings until they are ready to install.
4. Lubricate new or used serviceable bearings before installation. When pressing a bearing into a retainer or bore, apply pressure to the outer race. If the bearing is to be installed on a shaft, apply pressure to the inner race.

Gaskets

Check that holes in gaskets align with openings in the mating parts. If it becomes necessary to hand-fabricate a gasket, use gasket material or stock of equivalent material and thickness. Be sure to cut holes in the right location, as blank gaskets can cause serious system damage.

Bolt Usage and Torque Application

1. Use bolts of proper length. A bolt which is too long will bottom before the head is tight against its related part. If a bolt is too short, there will not be enough thread area to engage and hold the part properly. When replacing bolts, use only those having the same specifications of the original, or one which is equivalent.
2. Unless specific torque requirements are given within the text, standard torque values should be used on heat-treated bolts, studs, and steel nuts, in accordance with recommended shop practices. (See Torque Chart Section 1.)

Hydraulic Lines and Electrical Wiring

Clearly mark or tag hydraulic lines and electrical wiring, as well as their receptacles, when disconnecting or removing them from the unit. This will assure that they are correctly reinstalled.

Hydraulic System

1. Keep the system clean. If evidence of metal or rubber particles are found in the hydraulic system, drain and flush the entire system.
2. Disassemble and reassemble parts on clean work surface. Clean all metal parts with non-flammable cleaning solvent. Lubricate components, as required, to aid assembly.

Lubrication

Service applicable components with the amount, type, and grade of lubricant recommended in this manual, at the specified intervals. When recommended lubricants are not available, consult your local supplier for an equivalent that meets or exceeds the specifications listed.

Battery

Clean battery, using a non-metallic brush and a solution of baking soda and water. Rinse with clean water. After cleaning, thoroughly dry battery and coat terminals with an anti-corrosion compound.

Lubrication and Servicing

Components and assemblies requiring lubrication and servicing are shown in the Lubrication Chart in Section 1.

2.3 LUBRICATION AND INFORMATION

Hydraulic System

1. The primary enemy of a hydraulic system is contamination. Contaminants enter the system by various means, e.g., using inadequate hydraulic oil, allowing moisture, grease, filings, sealing components, sand, etc., to enter when performing maintenance, or by permitting the pump to cavitate due to insufficient system warm-up or leaks in the pump supply (suction) lines.
2. The design and manufacturing tolerances of the component working parts are very close, therefore, even the smallest amount of dirt or foreign matter entering a system can cause wear or damage to the components and generally results in faulty operation. Every precaution must be taken to keep hydraulic oil clean, including reserve oil in storage. Hydraulic system filters should be checked, cleaned, and/or replaced as necessary, at the specified intervals required in the Lubrication Chart in Section 1. Always examine filters for evidence of metal particles.
3. Cloudy oils indicate a high moisture content which permits organic growth, resulting in oxidation or corrosion. If this condition occurs, the system must be drained, flushed, and refilled with clean oil.
4. It is not advisable to mix oils of different brands or types, as they may not contain the same required additives or be of comparable viscosities. Good grade mineral oils, with viscosities suited to the ambient temperatures in which the machine is operating, are recommended for use.

NOTE: *Metal particles may appear in the oil or filters of new machines due to the wear-in of meshing components.*

Hydraulic Oil

Refer to Section 1 for recommendations for viscosity ranges.

Changing Hydraulic Oil

1. Filter elements must be changed after the first 50 hours of operation and every 300 hours (unless specified otherwise) thereafter. If it is necessary to change the oil, use only those oils meeting or exceeding the specifications appearing in this manual. If unable to obtain the same type of oil supplied with the machine, consult local supplier for assistance in selecting the proper equivalent. Avoid mixing petroleum and synthetic base oils. JLG Industries recommends changing the hydraulic oil annually.
2. Use every precaution to keep the hydraulic oil clean. If the oil must be poured from the original container into another, be sure to clean all possible contaminants from the service container. Always clean the mesh element of the filter and replace the cartridge any time the system oil is changed.
3. While the unit is shut down, a good preventive maintenance measure is to make a thorough inspection of all hydraulic components, lines, fittings, etc., as well as a functional check of each system, before placing the machine back in service.

Lubrication Specifications

Specified lubricants, as recommended by the component manufacturers, are always the best choice, however, multi-purpose greases usually have the qualities which meet a variety of single purpose grease requirements.

Should any question arise, regarding the use of greases in maintenance stock, consult your local supplier for evaluation. Refer to Section 1 for an explanation of the lubricant key designations appearing in the Lubrication Chart.

2.4 CYLINDER DRIFT TEST

Maximum acceptable cylinder drift is to be measured using the following methods.

Cylinder Drift

Table 2-2. Cylinder Drift

CYLINDER BORE DIAMETER		MAX ACCEPTABLE DRIFT IN 1 MINUTE	
INCHES	MM	INCHES	MM
2.1	55	0.02	0.53
2.3	60	0.021	0.54
2.5	65	0.013	0.35
2.7	70	0.026	0.68
2.9	75	0.013	0.35
3.1	80	0.011	0.29
3.7	95	0.009	0.23
3.9	100	0.007	0.2
4.5	115	0.005	0.15
4.9	125	0.004	0.12
6.1	155	0.002	0.07

Drift is to be measured at the cylinder rod with a calibrated dial indicator. The cylinder oil must be at ambient temperature and temperature stabilized.

The cylinder must have the normal load, which is the normal platform load applied.

If the cylinder passes this test, it is acceptable.

2.5 PINS AND COMPOSITE BEARING REPAIR GUIDELINES

Filament wound bearings.

1. Pinned joints should be disassembled and inspected if the following occurs:
 - a. Excessive sloppiness in joints.
 - b. Noise originating from the joint during operation.
2. Filament wound bearings should be replaced if any of the following is observed:
 - a. Frayed or separated fibers on the liner surface.
 - b. Cracked or damaged liner backing.
 - c. Bearings that have moved or spun in their housing.
 - d. Debris embedded in liner surface.
3. Pins should be replaced if any of the following is observed (pin should be properly cleaned prior to inspection):
 - a. Detectable wear in the bearing area.
 - b. Flaking, peeling, scoring, or scratches on the pin surface.
 - c. Rusting of the pin in the bearing area.
4. Re-assembly of pinned joints using filament wound bearings.
 - a. Housing should be blown out to remove all dirt and debris...bearings and bearing housings must be free of all contamination.
 - b. Bearing / pins should be cleaned with a solvent to remove all grease and oil...filament wound bearing are a dry joint and should not be lubricated unless otherwise instructed (i.e. sheave pins).
 - c. Pins should be inspected to ensure it is free of burrs, nicks, and scratches which would damage the bearing during installation and operation.

2.6 WELDING ON JLG EQUIPMENT

NOTE: This instruction applies to repairs, or modifications to the machine and to welding performed from the machine on an external structure, or component.

Do the Following When Welding on JLG Equipment

- Disconnect the battery.
- Disconnect the moment pin connection (where fitted).
- Ground only to structure being welded.

Do NOT Do the Following When Welding on JLG Equipment

- Ground on frame and weld on any other area than the chassis.
- Ground on turntable (turret) and weld on any other area than the turntable.
- Ground on the platform/support and weld on any other area than the platform/support.
- Ground on a specific boom section and weld on any other area than that specific boom section.
- Allow pins, wear pads, wire ropes, bearings, gearing, seals, valves, electrical wiring, or hoses to be between the grounding position and the welded area.

NOTICE

FAILURE TO COMPLY WITH THE ABOVE REQUIREMENTS MAY RESULT IN COMPONENT DAMAGE (I.E. ELECTRONIC MODULES, SWING BEARING, COLLECTOR RING, BOOM WIRE ROPES ETC.).

SECTION 3. CHASSIS & TURNTABLE

3.1 RUBBER TRACK MAINTENANCE/REPLACEMENT

Checking Track Tension

Stop the machine on a flat and solid ground. Raise the machine off the ground safely and, if needed, support it by applying stable blocks or jack stands under the undercarriage frame. In correspondence with the undercarriage central roller, measure distance "A" of the bottom of the roller to the hard internal part of the rubber belt. Track tension is normal if measure "A" is between 10 and 15 mm. If the tension is not within the above measure, or too tight, please follow the procedure illustrated in the following paragraph.

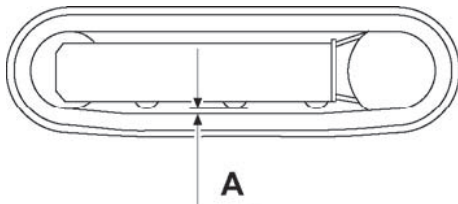

Figure 3-1. Tensioning Check 1

As an alternative to the above-mentioned procedure, you can follow the procedure below. In this case, the check is less accurate and precise. However, effective for evaluating if the rubber track is too slack.

Stop the machine on a flat and solid ground. In correspondence of the upper skid of the carriage, measure distance of the bottom of the skid to the hard internal part of the rubber belt, lifting the belt manually. The track tension is normal if measure "A" is between 10 and 15 mm. If the tension is not within the above measure, or too tight, please follow the procedure illustrated in the following paragraph.

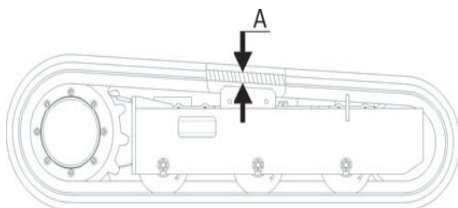

Figure 3-2. Tensioning Check 2

Tensioning Rubber Track

⚠ DANGER

THE GREASE CONTAINED IN THE HYDRAULIC TRACKS IS UNDER PRESSURE. IF THE VALVE TRACK TENSION IS TOO LOOSE, IT COULD BE EXPELLED UNDER THE EFFECT OF THE PRESSURE OF GREASE, SERIOUSLY ENDANGERING THE SAFETY OF THE OPERATOR.

WHEN GRAVEL OR MUD IS STUCK BETWEEN THE SPROCKET TEETH AND TRACK LINKS, REMOVE IT BEFORE TIGHTENING THE TRACKS.

To tighten the tracks, connect a grease gun to grease fitting 2 and add grease until the track tension reaches the indicated values (preferably use a pneumatic pump with 100 bar operating pressure). Before start the machine clean up any grease spillage.

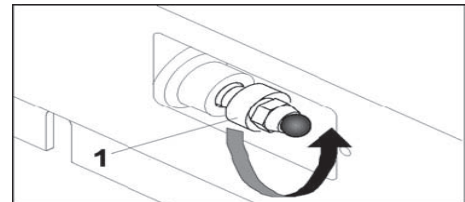

Figure 3-3. Tensioning Valve

Removing Rubber Track

Stop the machine on a flat and solid ground. Raise the machine off the ground safely and, if needed, support it by applying stable blocks or jack stands under the undercarriage frame.

1. To loosen the track, slowly unscrew grease release valve (1) counterclockwise for no more than a turn. If the grease does not start drain, slowly rotate the track. If also in this case the grease not emerges repeat the rotation of a lap of the valve and then slowly rotate the track. Repeat these steps until the grease begins to drain by unscrewing the valve of not more than one turn at a time.

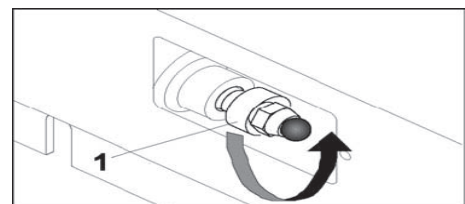

Figure 3-4. Draining Valve

⚠ DANGER

THE GREASE CONTAINED IN THE HYDRAULIC TRACKS IS UNDER PRESSURE. IF THE VALVE TRACK TENSION IS TOO LOOSE, IT COULD BE EXPELLED UNDER THE EFFECT OF THE PRESSURE OF GREASE, SERIOUSLY ENDANGERING THE SAFETY OF THE OPERATOR.

2. Use a pry bar (4) of adequate length to force a tooth of the central wheel out of the idler, then rotate the track slowly (5) using the pry bar to help it out, if necessary. Force (6) sideways to slide the track and lift it from the idler.

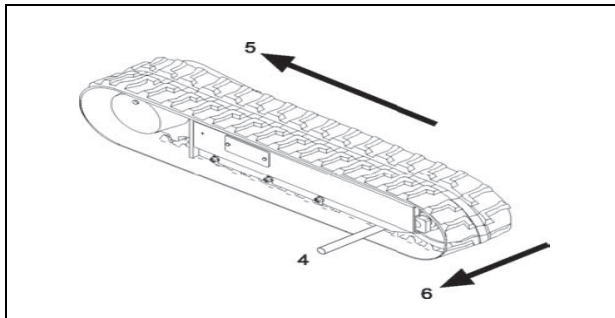

Figure 3-5. Removing Rubber Track Example

Installing Rubber Track

1. Starting with the machine undercarriage raised in conditions of safety provided of suitable supports stable below the undercarriage frame to support the machine.

⚠ DANGER

BEFORE INSTALLING THE RUBBER TRACKS, MAKE SURE THAT YOU ARE ALWAYS IN SAFE CONDITIONS WITH THE MACHINE SUSPENDED FROM THE GROUND.

2. Check that the grease contained in the hydraulic cylinder has been removed.
3. Mesh the track links with the track teeth of sprocket wheel and place the other end of the track on the idler.
4. Rotate the drive wheel to reverse slowly (7) pushing into the frame. If necessary, help yourself with a pry bar (8), especially to “walk” the first teeth in past the idler.

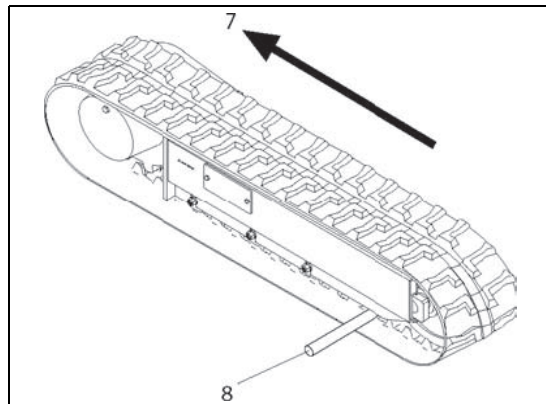

Figure 3-6. Rubber Track Installation Example

5. Make sure that the track links are properly meshed in the sprocket and idler.
6. Adjust the track tensioning “Tensioning rubber track”.
7. Lower the undercarriage down to the ground.

3.2 UNDERCARRIGE COMPONENTS

Machine Positioning

1. Stabilize the machine on level ground.
2. Fully extend the undercarriage.
3. Remove the tracks (see sub-section 3.1).
4. Remove the key ignition, and a tag with warning do no start the machine.

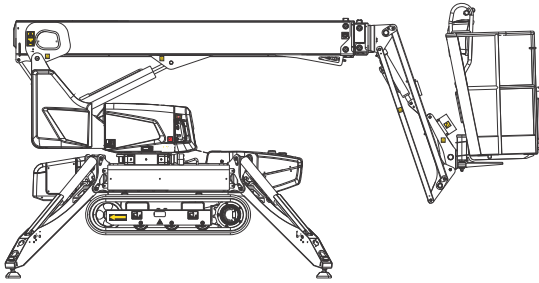

Figure 3-7. Machine Positioning

Replacement Roller Lower Wheel and Tracks Adjuster

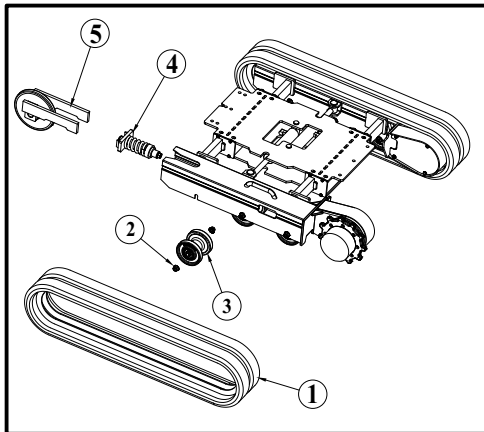

Figure 3-8. Replacement Roller Lower Wheel And Tracks Adjuster

Disassembly

1. Remove the nuts 2 on the lower roller.
2. Remove the lower roller 3.
3. Remove the front idler 5.
4. Remove the tracks adjuster 4.

Assembly

1. Fit the tracks adjuster 4.
2. Install the front idler 5.
3. Install the lower roller 3.
4. Apply loctite 243 and torque the nuts 2 on the lower roller at 125 Nm (92 ft. lbs.).

Replacement Sprocket and Gear Motor

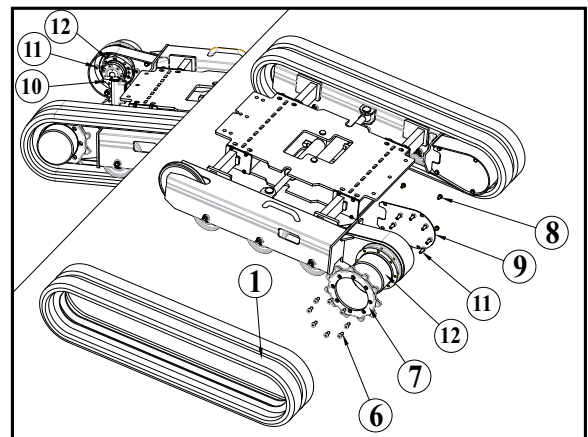

Figure 3-9. Replacement Sprocket And Gear Motor

Sprocket Removal

1. Fully extend the undercarriage.
2. Remove the tracks (see sub-section 3.1).
3. Remove the key ignition, and a tag with warning do not start the machine.
4. Remove screws 6.
5. Remove the sprocket 7.

Gear Motor Removal

1. Remove cover 9.
2. Disconnect and tag the hydraulic hoses from the gear motor.
3. Remove the valve 10 to access all the screws 11 (on single speed versions only).
4. Remove the screws 11.
5. Remove the motor 12.

Gear Motor Installation

1. Fix the screws 11.
2. Instal the valve 10.
3. Connect the Hydraulic hoses.
4. Instal the cover 9.

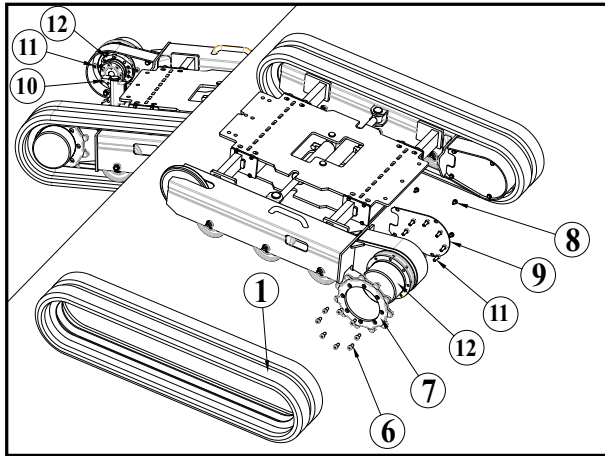

Figure 3-10. Gear Motor Installation

Sprocket Installation

1. Instal the sprocket.
2. Instal the screws 6.

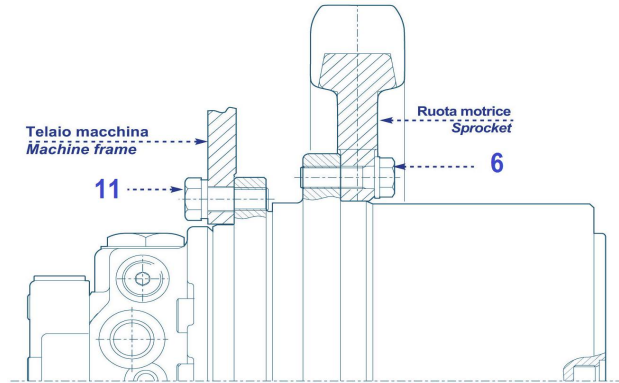

Figure 3-11. Sprocket Installation

Table 3-1. Final Drive Torque Values

MACHINE MODEL	SPROCKET SCREW N. 6 TORQUE VALUES	FINAL DRIVE SCREW N. 11 TORQUE VALUES
X13SJP-X13SJN	M12x1.5 - Nm 50	M10x25 - Nm 70

3.3 TRACKS EXTENSION REMOVAL

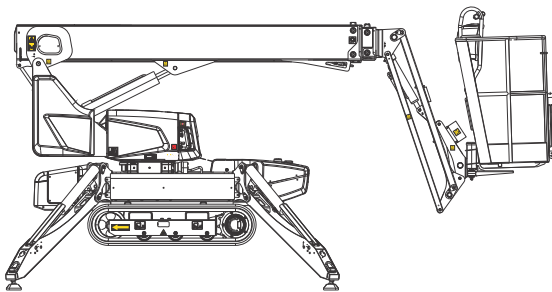

Figure 3-12. Sprocket Installation

1. Stabilize the machine on level surface.
2. Fully extend the undercarriage.
3. Turn OFF the machine.
4. Remove the key ignition, and a tag with warning do not start the machine.
5. Open the hydraulic cap, and operate the function undercarriage extend/retract to discharge any residual pressure in the system.

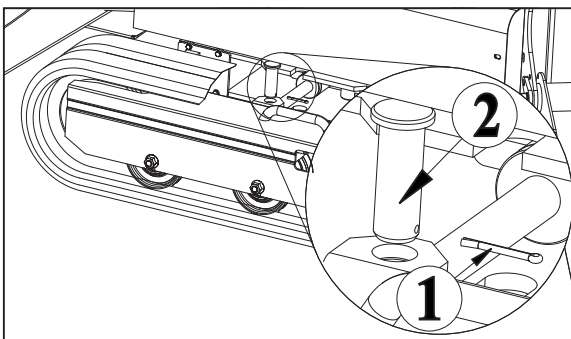

Figure 3-13.

6. Remove the cotter pin 1 - Figure 3-13.
7. Remove the pin 2.

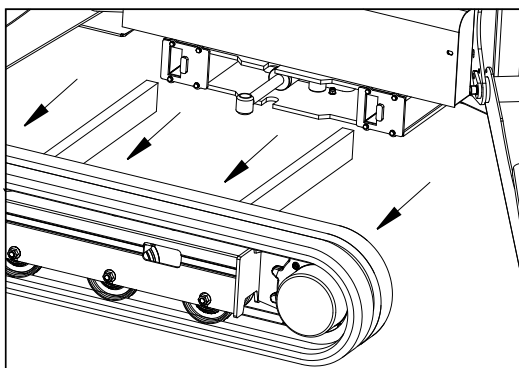

Figure 3-14.

8. Using a suitable lifting device to remove the track frame.

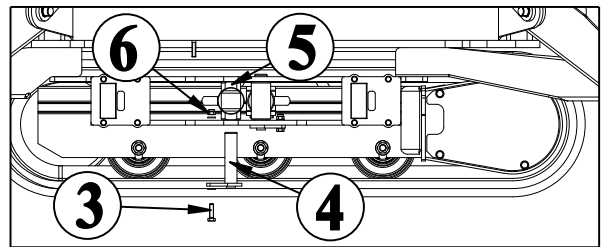

Figure 3-15.

9. Remove screw and nut 3 and 6.
10. Remove the pin 4.
11. Disconnect, tag and plug the hydraulic hoses from the cylinder extension.

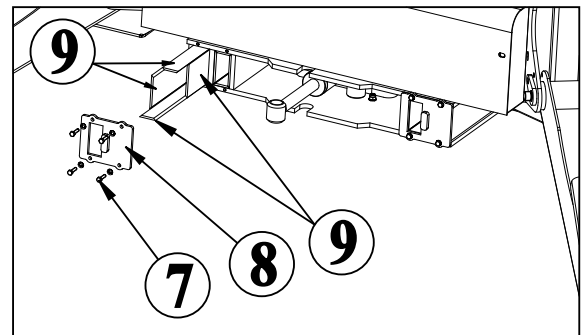

Figure 3-16.

12. Remove the cylinder.

NOTE: Before to install the undercarriage frame inspect the slide guides 9.

- a. Unscrew the screws 7.
- b. Remove the stop slide guides 8.
- c. Remove the slide guides 9.
- d. Check the thickness of slide guides, if less than 3.5 mm, damage, with deep scratches or with deformation, replace it. Otherwise clean them and install by adding Grease GR MU EP1 before to install the track guides.
- e. Use medium strength Loctite (Loctite 243) on screws 7 and tightening torque of 10 Nm (7 ft. lbs.).

3.4 TRACK DRIVE

Table 3-2. Final Drive Models

MACHINE	TYPE	VOLTAGE
X13SJP-X13SJN	Electric	15V AC

Product Identification

The data to identify the product are shown on the identification plate.

Information

For all inquiries regarding general information on the product, spare parts, assistance etc, always give the identification data stamped on the ID plate.

The plate must not be removed or damaged during the life of the product. The following illustration shows how the data is set out.

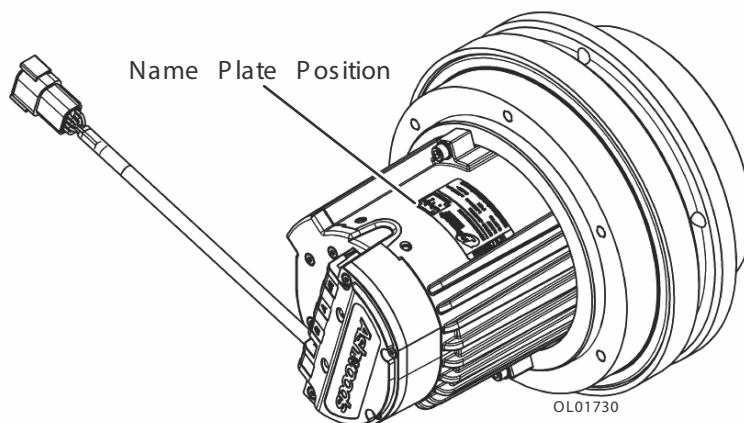

Figure 3-17. Name Plate Position

3.5 SWING DRIVE (IMO)

Technical Data – Type Plate

IMO ANTRIEBSEINHEIT

Drawing No.

Identification - Code Module

www.imo.de

Figure 3-18. Type Plate

The type plate is on the housing and contains the following information:

- Manufacturer
- Drawing no./type
- Identification code consisting of: Order number, year of manufacture and consecutive number
- Module
- Web address

Structure and Function

Brief description

Slew drives are used for concurrent transmission of axial and radial forces, as well as transmission of tilting moments. Slew drives consist of a ball or roller slewing ring, hydraulic or electric drives, and a completely enclosing housing. Force is transmitted to the mounting structure through bolts. For this purpose through holes or threads are provided in the inner and outer ring.

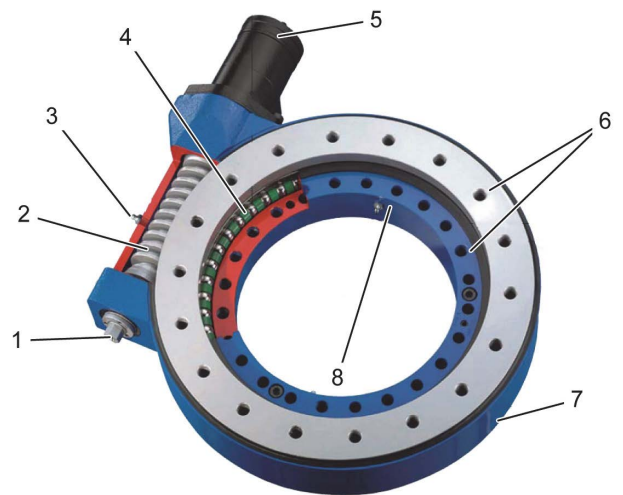

Figure 3-19. Slew Drive WD-L

1. Connection for options: Potentiometer, permanent brake or front-end brake
2. Worm shaft
3. Lubricating nipple
4. Ball slewing ring
5. Option: Drive motor
6. Bolted unions for the mounting structure
7. Housing
8. Lubricating nipple

Structure and Function

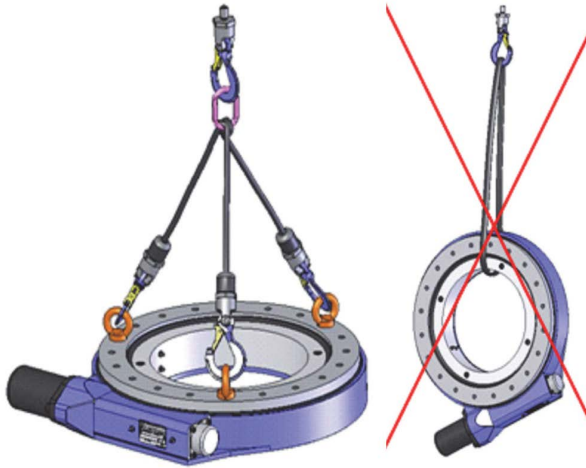

Figure 3-20. Use Suitable Lifting Gear - Never Transport Product

Unpacked slew drives can be transported with lifting gear when using eye bolts under the following conditions.

- The lifting gear must be configured appropriately for the weight of the transport units.
- The ring bolts must be configured appropriately for the weight of the transport unit.
- The slew drive shall only be transported by itself, without attached parts.
- Maintain the insertion depth prescribed by the manufacturer.
- If insertion depth is not prescribed, then a minimum insertion depth of 1.5 x the bolt diameter must be selected.
- Transport within the company shall only be executed horizontally.

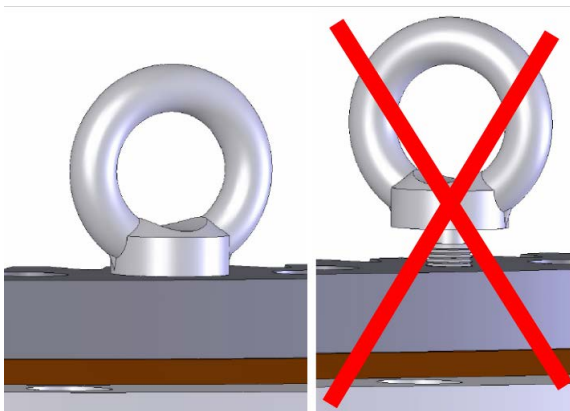

Figure 3-21. Always Use The Full Length Of The Thread

Maintenance Tasks

Inspecting The Mounting Bolts

NOTICE

TO COMPENSATE FOR SETTLING, THE BOLTS MUST BE RETIGHTENED WITH THE PRESCRIBED TIGHTENING TORQUE. RETIGHTENING MUST BE EXECUTED WITHOUT EXERTING ADDITIONAL EXTERNAL STRESS ON THE BOLTED UNION.

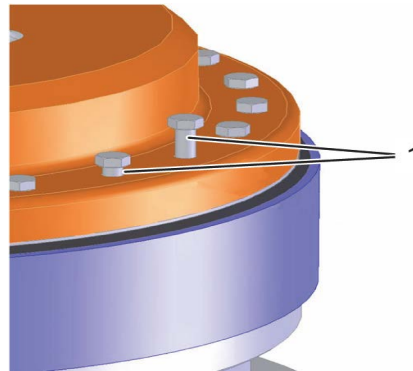

Figure 3-22. Inspecting The Mounting Bolts

1. Detached bolt

Execution only by a specialist.

- Special tools required:
 - Torque wrench
 - Hydraulic clamping fixture
- Replace loose and detached bolts or nuts and washers with new bolts, nuts and washers.
- Use the same bolt size and bolt quality.

Lubricating The Slew Drive

NOTICE

REGULARLY LUBRICATE THE SLEW DRIVES TO PROLONG THEIR SERVICE LIFE AND ENSURE SAFE OPERATION.

NOTICE

ALWAYS USE THE LUBRICANTS SPECIFIED IN THE ORDER DRAWING. IF USING OTHER LUBRICANTS PAY ATTENTION TO THE RELATIVE MIX ABILITY OF THE SUBSTANCES. THE STANDARD LUBRICANTS USED ARE "R.TECC NORPLEX LKP2" FROM RHENUS, OR THE GREASE "OPTIMOL LONGTIME PDO" FROM CASTROL. IF IN DOUBT, OR IF THERE IS NO SPECIFICATION ON THE DRAWING, CONSULT WITH OUR CUSTOMER SERVICE. USING THE WRONG LUBRICANT MAY CAUSE DAMAGE TO THE SLEW DRIVES AND REDUCE THE SERVICE LIFE. IN THIS CASE, ANY WARRANTY SHALL BE EXCLUDED. COMPLY WITH THE INSTRUCTIONS PROVIDED BY THE LUBRICANT MANUFACTURER.

- If possible, use a central lubrication system to lubricate the raceway system. In this regard ensure that the hoses are filled with grease at commissioning and that the storage tanks are regularly topped up with grease.
- An automatic re-lubricating system significantly facilitates re-lubrication for the raceway system and the toothing. Functional safety as well as wear behavior are improved.
- Comply with the instructions in the operating manual provided by the respective manufacturer for lubrication of optional intermediate gear units, brakes, and motors.
- If it is evident that moisture has penetrated into the slew drive, or has been absorbed by the grease, you must re-lubricate more intensively.

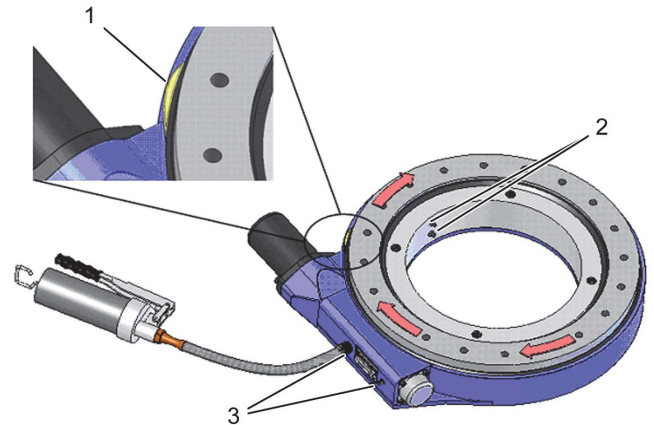

Figure 3-23. Lubricating The Slew Drive

1. Fresh lubricant.
2. Lubricating nipple, bearing ring.
3. Lubricating ring housing.
4. In succession, press grease into all lubricating nipples while simultaneously turning the slew drive all the way through, until a continuous collar of grease forms under at least one seal.
5. Ensure that old lubricant can escape without obstruction.

3.6 POWER SYSTEM X13SJP - X13SJN

The X13SJP - X13SJN is configured with a Lithium battery pack that supplies power to a variable speed, three-phase electric motor.

The Table (below) shows the engine speeds of the twin powered according to the function activated:

Lithium Powered Units

48V Lithium Battery System



System Function

The level of charge of the lithium pack is shown by the icon on the right lower corner of the display, while more detail are reachable in service menu input SOC (State Of Charge).

With the State of Charge (SOC) lower than 20%, the remote control beeper is activated to inform the operator that battery pack needs to be charged.

When SOC is lower than 15%, inverter feeds the electric motor to run at half of the usual rev speed.

When SOC is lower than 4%, inverter feeds the electric motor to run at lowest rev speed, and the following icon are displayed o remote control display:



“EXTRA LOW SPEED” ICON



“CONNECT TO THE ELECTRIC GRID” ICON

With SOC at 0%, the machine could not be operate and the icon "CONNECT TO THE ELECTRIC GRID" is displayed in the middle of the remote control display.

Lithium Cells

Number of cells in the battery pack	27 cells
Nominal voltage of each cell	3,7 Volt
Capacity of one cell	40 Amps/h
Nominal features of the complete pack	48 Volt -80 Amps/h
Max cell nominal voltage	4,2 Volt
Min cell operating voltage	2,7 Volt
DOD	90%
Charge cycles	3000 full cycles
Memory effect	NO

Lithium cells are managed by BMS (Battery Management System) that continuously manages charge and discharge operations, monitors cells parameters including their tensions and their temperatures, while in case of failure opens the internal contactor insulating the Lithium pack.

Battery Charger

The on-board battery charged is activated when its plugged, if present it has to be used the plug fitted on the lithium pack, otherwise the one close to the magneto-thermal switch.

DC-DC Transformer

The Lithium system works at 48 V nominal, while the machine electrical components and electronic system electronic boards operate at 12 V. The Lithium system includes a DC-DC transformer that converts the 48 V into 13,5 V.

Machine is equipped with a 12 V lead battery required to switch ON the Lithium system and ECM1 module (Electric Motor Control).

Electric Motor

Three-phase
48 Volt
2000 Watt

Electric motor is fed through an inverter that converts the lithium-pack direct current (DC) into three-phase alternating current (AC).

Electric Motor Three-Phase Control Speed System

The ECM1 module communicates the preset required rpm to the inverter. The inverter feeds the electric motor with the correct frequency in order to achieve the selected nominal rpm.

Located by the speed sensor on the electrical motor, the ECM1 module verifies accurate rpm.

Table 3-3 (below) shows the electric motor rpm range according to the function activated:

Table 3-3.

Function	ELECTRIC MOTOR REVS (RPM)		
	TURTLE	NORMAL	HARE
TRACKS	1500	2100	2100 + SECOND SPEED
TRACKS WIDENING	1500	2100	2100
1-2 BOOMS DOWN (Summing oil pumps flow)	750	1500	1500
1-2 BOOMS DOWN	750	1500	1500
3 BOOM UP	750	1800	1800
3 BOOM DOWN	750	1500	1500
1-2 AND 3 BOOMS TOGETHER WITH AT LEAST ONE UP	1500	1800	1800
1-2 AND 3 BOOMS TOGETHER, NONE UP	1050	1500	1500
TELESCOPE OUT (Summing oil pumps flow)	1500	1800	1800
TELESCOPE IN	1500	1800	1800
SLEW ROTATION	750	1500	1500
JIB	750	1050	1050
PLATFORM ROTATION	750	1050	1050
PLATFORM LEVELLING	750	1050	1050

NOTE: For the outriggers function, the electric motor revs will automatically adjusted follow the position of the outriggers. With all outriggers lift from the ground, the electric motor run at max revs, with one or more outriggers in contact to the ground, the electric motor run at min revs. Operating the counter clocking turn of the tracks the electric motor revs are set at lower speed.

For the time of activation of multiple areal functions at the same moment with jib, platform rotation and platform leveling, the engine will run at min rev.

For the functions set with the summing oil flow, the sum of the oil flow is feasible while operating the function only and not in combine with other function/s at the same moment.

NOTE: RPM Tolerances are ± 50 .

Temperature Ongoings (Heaters and Fans)

Lithium battery pack discharge and/or recharge, with positive lithium battery level (SOC>0), is possible over -10°C.

In cold environmental temperature (not lower than -25°C), the on-board electric heaters automatically warm up the cells, they are activated by the BMS when the minimum cell temperature goes down 0°C, they are automatically switched off when the minimum cell temperature raises over the 2°C.

In case of battery charger is connected, till 0°C it supplies only 3A in order to surely feeds only the heaters, waiting positive temperatures to recharge the cells.

In cold environmental temperature (from -25°C to 0°C), with null lithium battery level (SOC = 0), the heaters work only while the cable is plugged to the electric network (battery charger activated).

While heaters are working on the display will appear the icon batteries cold, and machine could be moved only in lower speed (turtle).



“BATTERY COLD / HEATER ACTIVATED” ICON

In hot environmental temperature, the fans system automatically cool down the cells, they are automatically activated by the BMS when cells temperature raises over 37°C, they are automatically switched off when cells temperature goes down the 35°C.

Diagnostics and Fault Codes

The main devices composing the lithium batteries system are able to carry out self-diagnosis informing the operator by the remote control display, in particular they eventually display informative icons and provide fault codes.

Self-diagnosis is carry out by:

- BMS (Battery Management System)
- Battery charger
- Inverter

Further information about Lithium system, fault codes and diagnose are detailed by Lithium system specific manual.

Lithium System Components Location

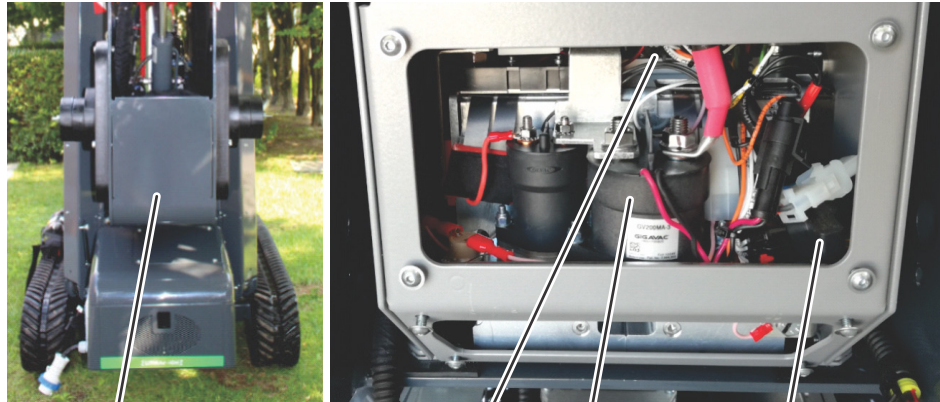

Battery Pack

1,2,5

3

4



8

7

- 1. BMS (Control Unit)
- 2. Cells
- 3. Internal Contactor
- 4. LEM Sensor

- 5. Temperature Sensors
- 6. DC-DC
- 7. Track Inverters
- 8. Pump Inverter

SECTION 4. BOOM & PLATFORM

4.1 BOOM MAINTENANCE

NOTICE

IF PERFORMING MAINTENANCE ON THE BOOM, DO NOT USE A LIFTING DEVICE TO LIFT THE BOOMS UNLESS THE HOLDING VALVES HAVE BEEN REMOVED FIRST. FAILURE TO DO SO WILL RESULT IN SEVERE DAMAGE TO THE BOOM.

Removal of the Boom Assembly

1. Remove the platform and platform support as follows:
 - a. Disconnect electrical cable from control console.
 - b. Tag and disconnect the hydraulic lines running to the rotate cylinders. Cap the hydraulic lines and ports.
 - c. Using an overhead crane or suitable lifting device, use nylon support straps to support the platform/support.

NOTE: *When removing the retaining pin from the rod end of the level cylinder, make sure the cylinder is properly supported.*

- d. Remove bolts and keeper pins that secures the retaining pins. Using a suitable brass drift and hammer, remove the retaining pins from the platform support.
2. Remove the boom from the turntable (turret) as follows:
 - a. Disconnect wiring harness from ground control harness connector.

NOTICE

HYDRAULIC LINES AND PORTS SHOULD BE CAPPED IMMEDIATELY AFTER DISCONNECTING LINES TO AVOID ENTRY OF CONTAMINANTS INTO SYSTEM.

- b. Tag and disconnect hydraulic lines from boom to control valve. Use a suitable container to retain any residual hydraulic fluid. Cap all hydraulic lines and ports.
 - c. Using a suitable lifting equipment, adequately support boom weight along entire length.
 - d. Remove the bolts and keeper pins securing the lift cylinder pivot pin. Using a suitable brass drift and hammer, remove the pivot pin from the lower boom.
 - e. Remove hardware securing the level link pivot pin. Using a suitable brass drift and hammer, remove the pin from the level link and turntable.

- f. Remove hardware securing the lower boom pivot pin. Using a suitable brass drift and hammer, remove pin from the turntable.
 - g. Using all applicable safety precautions, carefully lift boom assembly clear of turntable and lower to ground or suitable supported work surface.

Disassembly of the Main Boom

1. Loosen jam nuts on aft end of fly boom wear pad adjustment and loosen adjustments.
2. Using a portable power source, attach hose to telescope cylinder port block. Using all applicable safety precautions, activate hydraulic system and extend cylinder to gain access to cylinder rod retaining pin. Shut down hydraulic system.
3. Carefully disconnect hydraulic hose from retract port of cylinder. There will be initial weeping of hydraulic fluid which can be caught in a suitable container. After initial discharge, there should be no further leakage from the retract port.
4. Remove hardware securing telescope cylinder to the fly boom section, then remove pin from fly.
5. Remove hardware securing telescope cylinder to the base boom section.

NOTICE

WHEN REMOVING TELESCOPE CYLINDER FROM BOOM SECTIONS. CARE SHOULD BE TAKEN NOT TO LEAVE CYLINDER REST ON POWERTRACK WHICH COULD CAUSE DAMAGE TO POWERTRACK.

6. Using a suitable lifting device, remove telescope cylinder from boom sections.
7. Using a piece of tape, mark the length of hoses and wires from front of fly boom and bottom of base boom for reassembly.
8. Remove hardware securing the front wear pads on base boom section, remove wear pads.
9. Remove hardware securing the powertrack to the aft end of the fly boom section.
10. Using a suitable lifting device, remove fly boom from boom section.
11. Remove hydraulic lines and electrical cables from powertrack.
12. Remove hardware securing powertrack to the base boom section. Remove powertrack.

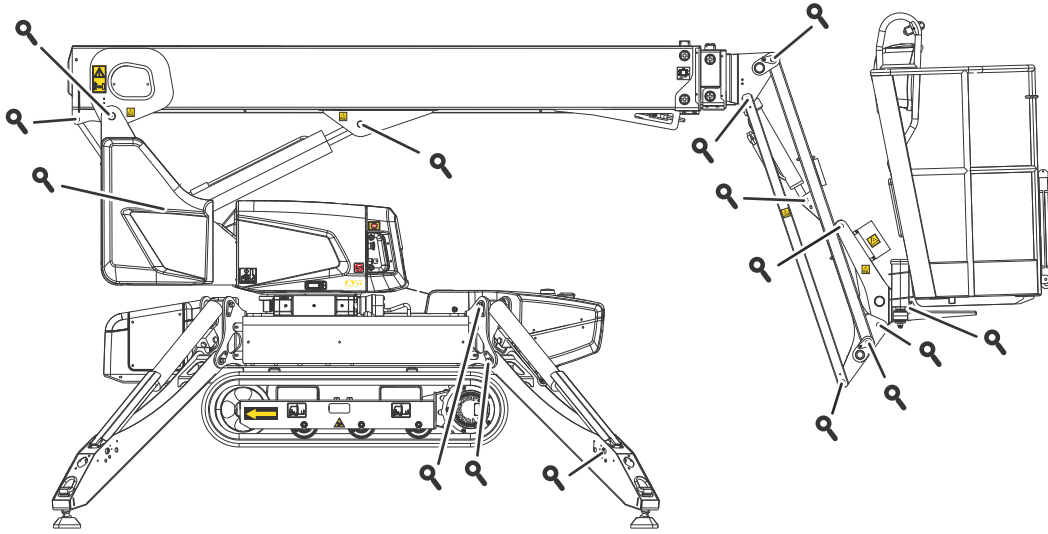

Figure 4-1. Inspect Pins X13SJP - X13SJN

Inspection

1. Inspect all boom pivot pins for wear, scoring or other damage, and for tapering or roundness. Replace pins as necessary.
2. Inspect lift cylinder pins for wear, scoring or other damage, and for tapering or roundness. Ensure pin surfaces are protected prior to installation. Replace pins as necessary.
3. Inspect telescope cylinder rod attach pin for wear, scoring or other damage. Replace pin as necessary.
4. Inspect inner diameter of boom pivot bushings for scoring, distortion, wear or other damage. Replace bushings as necessary.
5. Inspect wear pads for wear.
6. Inspect all threaded components for damage such as stretching, thread deformation, or twisting. Replace as necessary.
7. Inspect structural units of boom assembly for bending, cracking, separation of welds, or other damage. Replace boom sections as necessary.

Assembly of the Main Boom

1. Install powertrack to the attach point on the base boom section. Secure powertrack with the attaching hardware.
2. Install hydraulic lines and electrical cables into the powertrack.
3. Install wear pads to the aft end of the fly section.
4. Using suitable lifting equipment, slide fly section into the base section until powertrack attach point aligns with holes in side of base section.
5. Attach the powertrack to the aft end of fly boom section. Secure powertrack with the attaching hardware.
6. Using suitable lifting equipment, slide fly boom section out to gain access to telescope cylinder attach pin hole.
7. Measure the distance between the telescope cylinder port block attach point on base boom section and the attach point on fly boom section.
8. Connect a suitable auxiliary hydraulic power source to the telescope cylinder port block.
9. Extend the telescope cylinder the distance of the two attach points.
10. Secure the sling and lifting device at the telescope cylinder's approximate center of gravity, and lift the cylinder to the aft end of the boom assembly.

NOTICE

WHEN INSERTING THE TELESCOPE CYLINDER INTO THE BOOM, CARE MUST BE TAKEN NOT TO DAMAGE THE POWERTRACK ASSEMBLY.

11. Slowly slide the telescope cylinder into boom assembly, align rod end with attach point in fly section. Insert pin and secure with retaining ring.
12. Slowly slide the telescope cylinder into boom assembly, align barrel end with attach point in fly section. Insert pin and secure with retaining ring.
13. Install wear pads at front of base boom section. Adjust the wear pads to zero clearance.

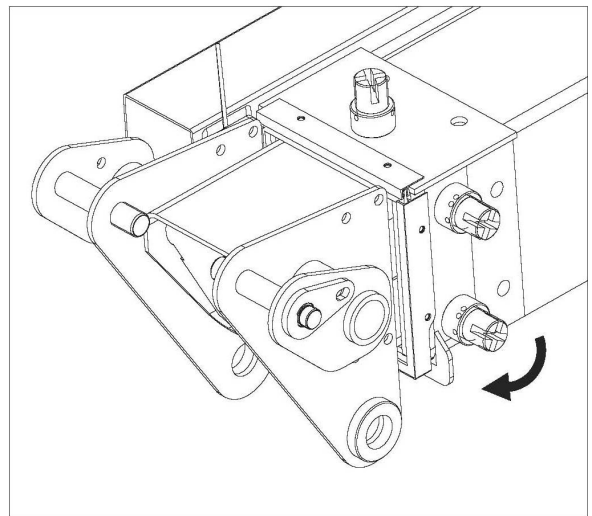

Figure 4-2. Adjustment Wear Pads

14. Adjust pads alternately side to side, so that fly boom section is centered in base boom section (lower wear pad with 1 mm gap).

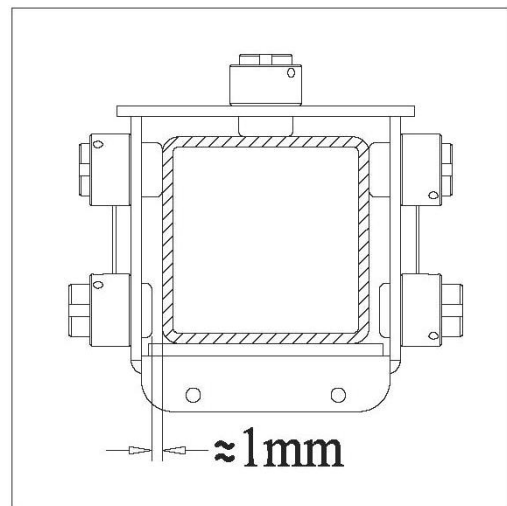

Figure 4-3. Adjustment Wear Pads

15. Turn the wear pad to expose the groove on the head to insert the cotter.

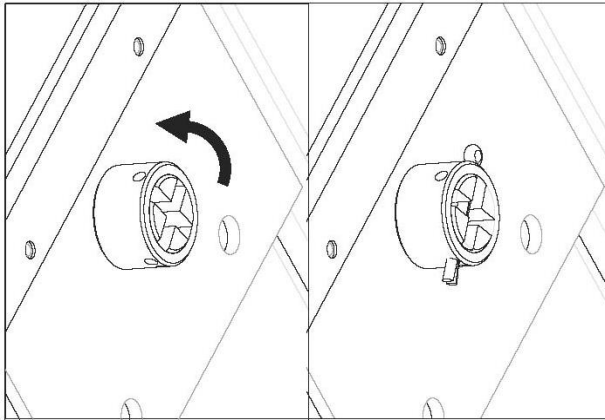

Figure 4-4. Groove on the Head

16. Disconnect auxiliary power source from telescope cylinder.

Installation of the Boom Assembly

1. Using suitable lifting equipment, position boom assembly on turntable so that boom pivot holes in both boom and turntable are aligned.

2. Install boom pivot pin, ensuring that location of the hole in pivot pin aligns with attach point on upright.
3. Using all applicable safety precautions, operate lifting equipment in order to position boom lift cylinder and level link so that holes in cylinder rod end and level link are aligned with the one in the turntable. Insert cylinder pins.
4. If necessary, gently tap pins into position with a soft headed mallet, ensuring that attach holes in pins are aligned with attach holes in boom structure. Secure with hardware.
5. Connect all hosing and wiring.
6. Install the platform to the boom assembly.
7. Connect all hosing and wiring at platform control station.
8. Using all safety precautions, operate machine systems and extend and retract boom for four or five cycles.
9. Shut down machine systems and check for leakage.

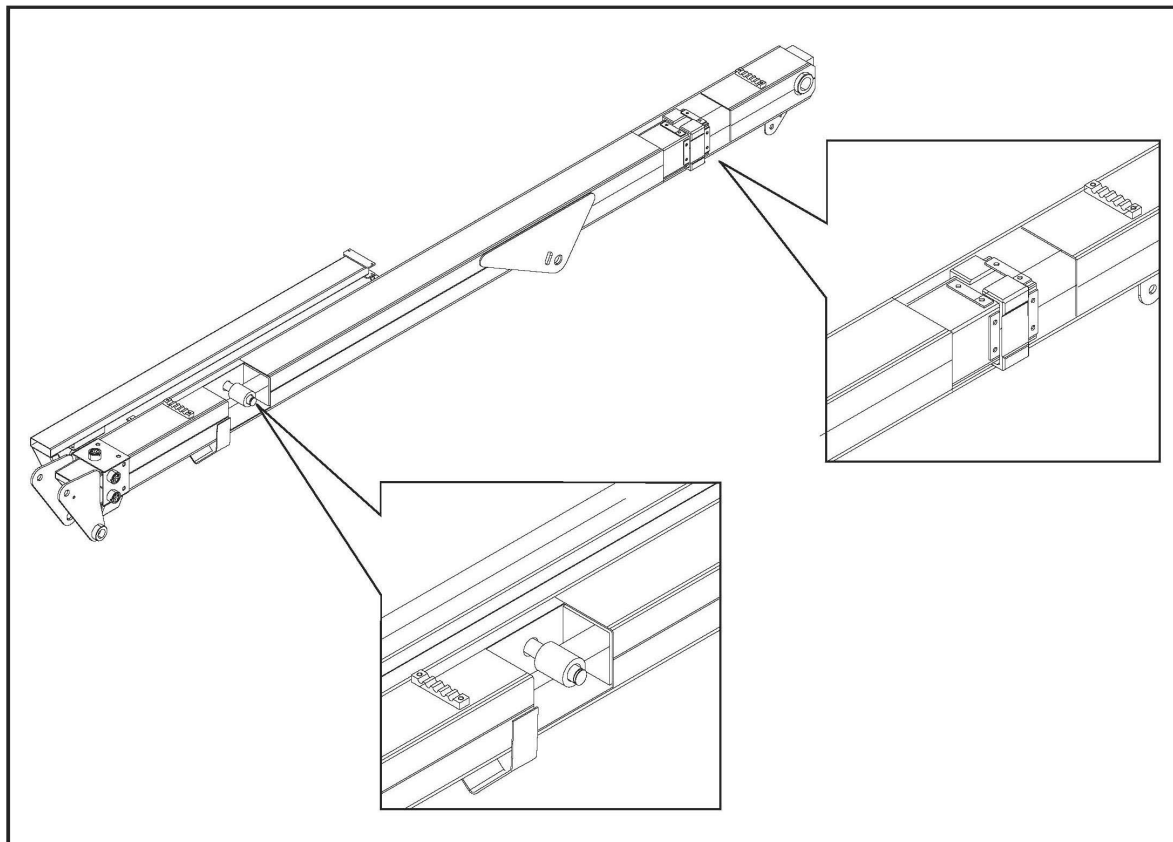

Figure 4-5. Boom Assembly

4.2 WIRE ROPE AND PULLEYS

CAUTION

WIRE ROPE CAN HAVE SHARP EDGES AND CAUSE SERIOUS INJURY. NEVER HANDLE WIRE ROPE WITH BARE HANDS.

Each day before using machine:

1. Raise boom approximately horizontal.
2. Extend and retract all boom sections.
3. Check for delayed movement in any section which indicates loose wire ropes.

WARNING

IF DELAYED MOVEMENT IS DETECTED IN WIRE ROPE OPERATION, LOWER PLATFORM TO STOWED POSITION, SHUT DOWN MACHINE, AND HAVE WIRE ROPES INSPECTED/SERVICED BY A QUALIFIED SERVICE TECHNICIAN. LOOSE OR MISADJUSTED WIRE ROPES COULD RESULT IN SERIOUS INJURY OR DEATH.

Inspection

NOTE: The pictures in this section are samples to show the replacement criteria of the rope.

If any one of the following situations is detected, the ropes or pulleys must be replaced.

1. Inspect ropes for broken wires, particularly valley wire breaks and breaks at end terminations.

NOTE: Flexing a wire rope can often expose broken wires hidden in valleys between strands.

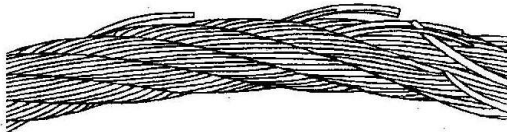

Figure 4-6.

2. Inspect wire ropes for corrosion.
3. Inspect wire ropes for kinks or abuse.

NOTE: A kink is caused by pulling down a loop in a slack lined during improper handling, installation, or operation.

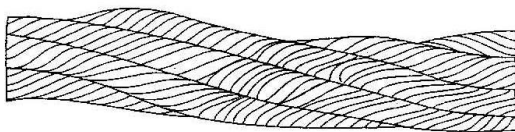

Figure 4-7.

4. Inspect sheaves for condition of bearing/pins.
5. Inspect sheaves for condition of flanges.
6. Inspect sheaves with a groove wearout gauge for excessive wear.

NOTE: Check groove so it may be clearly seen if the contour of the gauge matches the contour of the bottom of the groove.

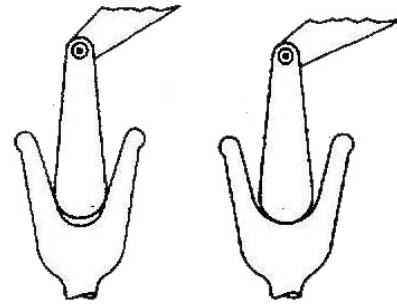

Figure 4-8.

7. Wire ropes passing inspection should be lubricated with wire rope lubricant prior to assembly.

Three Month Inspection

1. Remove all protection sumps from the third arm and the two extensions. Use a flashlight to visually check the state of the ropes and the extension pulleys.
2. Check the correct rope tension, trying to bend them manually. If they are pulled correctly they should not be able to move more than a few millimeters.
3. Check that in the extension arms exit phase the return ropes are sufficiently in traction in a way not to allow relative contact with the third arm.
4. Vice versa in the extension return phase, check that the outlet ropes are subject to a tension that allows them not to come into contact with the second extension or the cylinder.
5. Use a torque wrench to check the correct torque of all rope fixing nuts and the respective rocker arms; recommended torque 7.4 ft-lbs (10 Nm).

NOTE: If the tension of the ropes is not adequate, use the Ropes Tension Adjustment Procedure.

Seven Year or 3000 Hours Replacement

After seven years or 3000 hours of work, whichever comes first, all wire ropes, cables, and sheaves must be replaced completely.

4.3 ROPES TENSION ADJUSTMENT PROCEDURE

NOTE: Do not clamp on threads

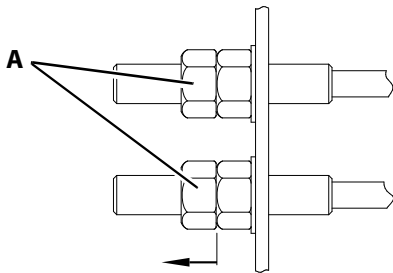

Figure 4-9. Counter-Nuts (Tensioner Nuts)

1. Loosen the register counter-nuts (A) by a few turns. Position them to access the adjustment nuts. (Two nuts with relative counter-nuts for extending ropes and one nut with relative counter-nut for retracting ropes rocker arm.)
2. Completely retract both extendable sections, then extend the second/outermost section so that the pin is 4 in (101 - 102 mm) from the edge of the next section.



Figure 4-10. Retracted Boom Pin to Arm Measurement

3. Remove the cotter pins on the slide adjusters. Tighten all to hold the boom sections stationary during rope tensioning procedure.

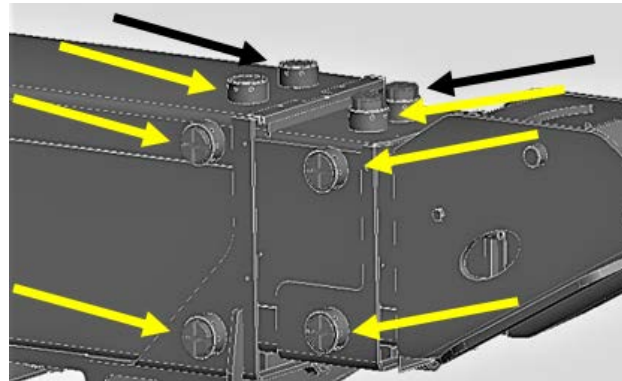

Figure 4-11. Slide Adjuster Positions

4. Tighten the nut on the return rope sling block to a torque of 3.7 ft-lbs (5 Nm).

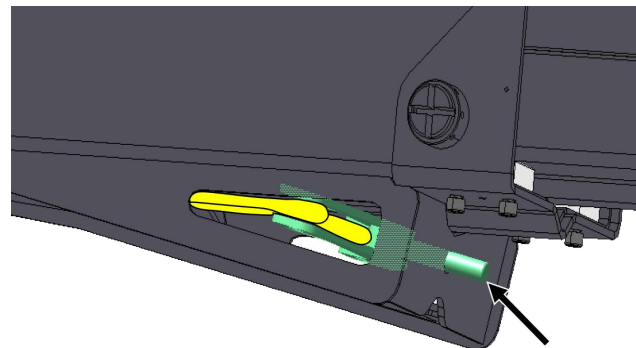

Figure 4-12. Return Rope Sling Block Location

5. Tighten the front side tensioner nuts of the two output cables to a torque of 3.7 ft-lbs (5 Nm). Keep ropes from rotating using a 14 mm wrench while turning front side nuts. Alternate turning of the nuts to ensure even rope tension.

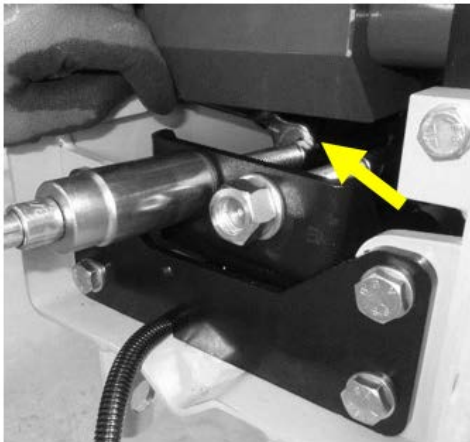

Figure 4-13. Cable Stop Block and Output Cables

6. Torque the nut on the return rope sling block to 7.4 ft-lbs (10 Nm).

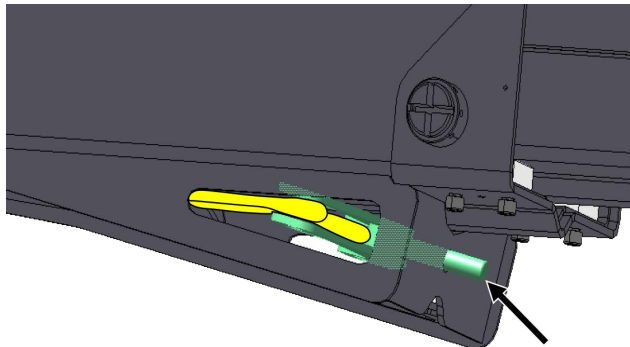

Figure 4-14. Return Rope Sling Block

7. Tighten the front side tensioner nuts of the two output cables to 7.4 ft-lbs (10 Nm). Keep ropes from rotating using a 14 mm wrench while tightening front side nuts. Alternate turning of the nuts to ensure even rope tension.

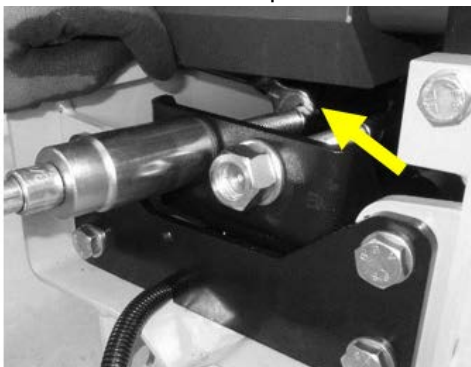

Figure 4-15. Cable Stop Block and Output Cables

8. Slightly loosen the slide adjusters of the boom sections and, supporting the arm with a bridge crane, fully open the extension to check correct operation.



Figure 4-16. Extended Boom Support Location

9. Fully retract the boom to check correct movement and operation.
10. Once the boom is fully retracted, check that the torque values are still 7.4 ft-lbs (10 Nm), first for the return rope sling block and then the nuts at the cable stop block.
11. Lock the tensioner nut at the return rope sling block with a second nut (M16).

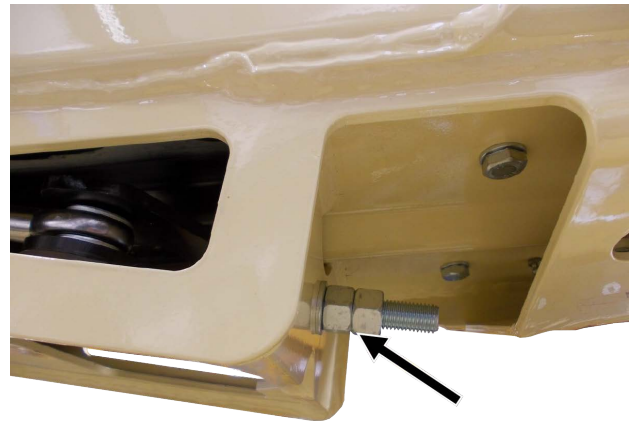

Figure 4-17. Sling Block Tensioner Nuts

12. Lock the tensioner nuts at the cable stop block with a second nut (M16).

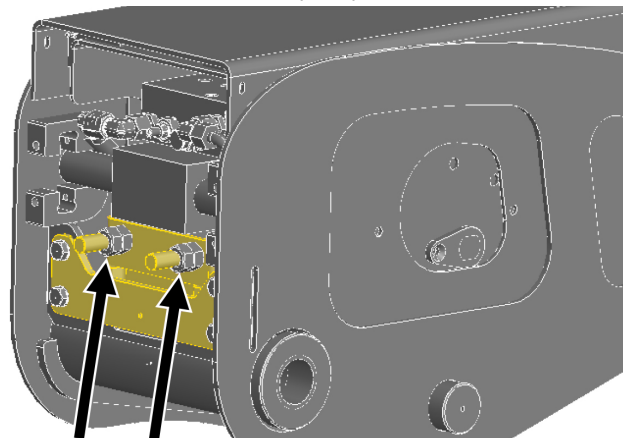

Figure 4-18. Cable Stop Block Tensioner Nuts

13. To begin centering and aligning the boom sections, loosen the slide adjusters.

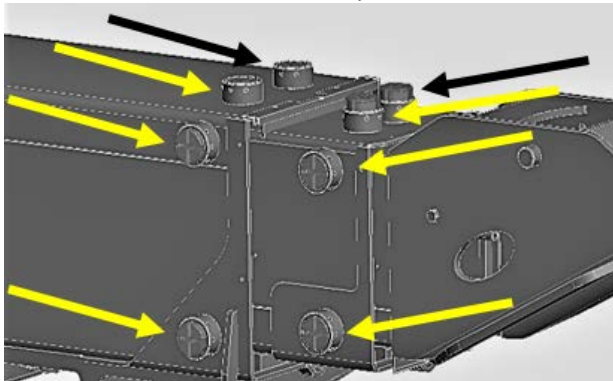

Figure 4-19. Slide Adjuster Positions

14. Center the boom sections.
15. Tighten each adjuster until it rests against the internal section without applying pressure.
16. Install new cotter pins.

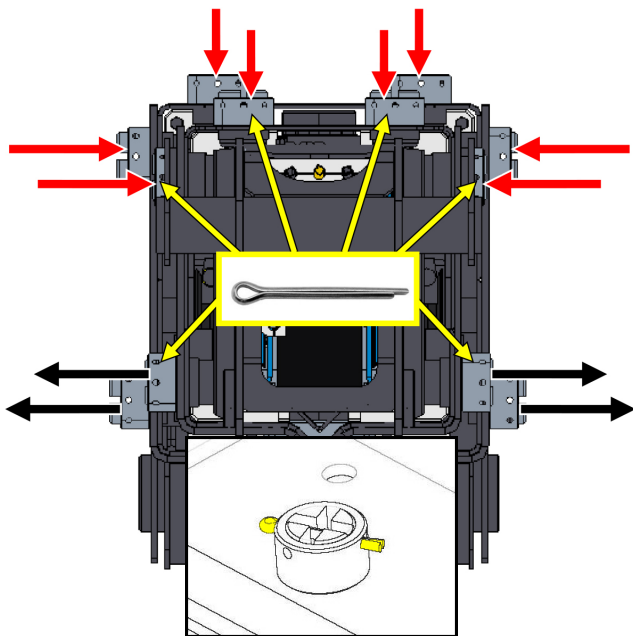

Figure 4-20. Slide Adjuster Points and Cotter Pins

4.4 PROXIMITY SENSOR ADJUSTMENT

Adjust the proximity sensor in order to obtain a gap of 2 mm between the sensor and the undercarriage ring plate.



Figure 4-21.

4.5 PLATFORM REMOVAL/INSTALLATION

Removal

NOTE: If the platform is removed only track movement is allowed.

1. Remove the platform/remote control box from the mounting support.
2. Loosen and remove the aluminium caps that secure the platform to the jib platform mounting posts.
3. Lift the platform off the mounting posts in an upward direction. Place platform aside for later installation.

Installation

1. Lift the platform and align the platform mounts with the jib mounting posts and lower until seated.
2. Secure the platform to the jib mounting posts with the aluminum threaded caps. Do not over-tighten.
3. Re-install the platform/remote control box into the mounting support on the platform.

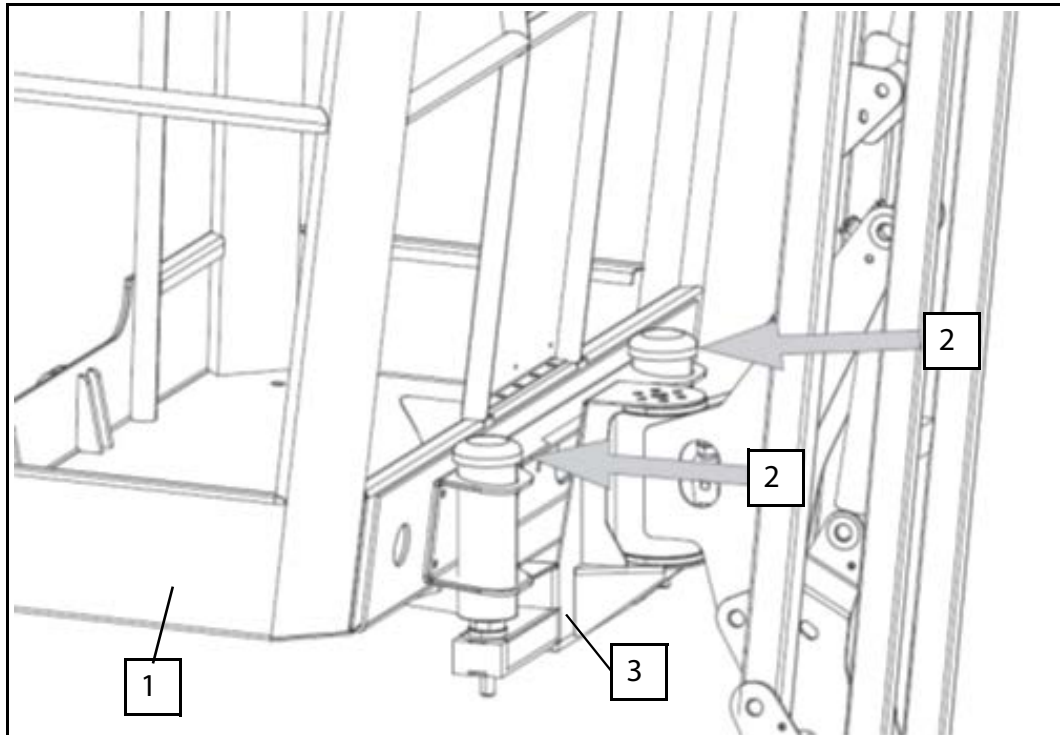

Figure 4-22.

4.6 SKYGUARD INSTALLATION - ONE PERSON PLATFORM

The purpose of this instruction is to install a SkyGuard system on JLG Compact Crawler Boom (platform capacity of one person) models listed below and with below pictured SkyGuard Bracket.

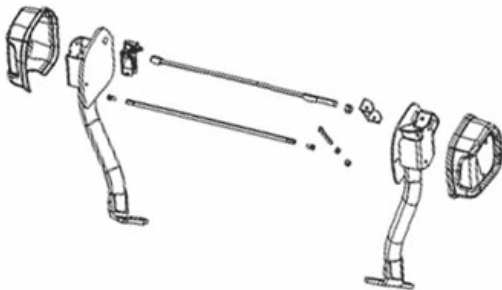
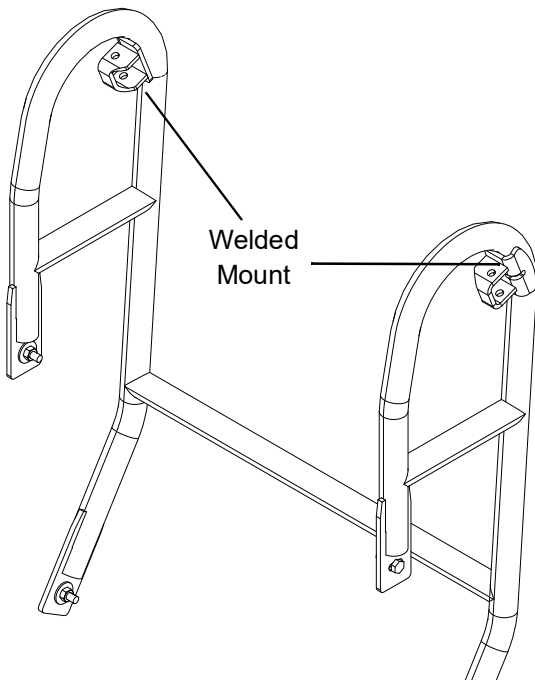

Figure 4-23. : Dual Side Entry Platform SkyLine and Bracket



SkyGuard Bracket with Mount

It is recommended that you read and thoroughly understand these instructions before starting this procedure.

NOTICE

USE ALL APPLICABLE SAFETY PRECAUTIONS WHILE WORKING ON, AROUND OR UNDER ANY MACHINERY.

Options/Accessories Prohibited When Installing This Kit:

- None

Tools & Equipment Required:

- Standard mechanic tools including 5/16 in. & 7/32 in. Allen Wrenches
- Tie Straps

Personnel Required:

- Qualified JLG equipment mechanic

Dual Side Entry Platform Parts List:

ITEM	PART NUMBER	DESCRIPTION	QTY
1	38302200	Support, Left	1
2	38302300	Support, Right	1
3	08310700	Cover, Right	1
4	08310800	Cover, left	1
5	08309700	Bar, Threaded	1
6	08132300	Bar, Fiberglass	1
7	3311601	Nut	1
8	18310600	Microswitch	1
9	383036Y1	Support, Bar	1

Parts List:

ITEM	PART NUMBER	DESCRIPTION	QTY
1	0641414	Bolt, 1/4-20x 1 3/4 LG	2
2	0700812	Bolt (Metric), 8x25 LG	4
3	3290801	Nut, M8x 1.25	4
4	3300430	Nut, Acorn 1/4- 20	2
5	3931424	Bolt, 1/4-20x1 1/2 LG	2
6	4711400	Washer, 1/4 DIA Plain Steel, Narrow	4
7	4811902	Washer, 8mm LG OD	4
8	37675400	Bracket, SkyGuard Support	1
9	1001186517	Cover, Platform Sensor	2
10	1001188889	Support, Shear Block	2
11	1001213890	Switch, SkyGuard	1
12	1001213891	Mount, Platform Sensor	1

Procedure:

1. Park the machine on the firm level surface, fully retract & lower the boom.
2. Extend all the four outriggers, set them to the auto levelling mode and set the machine to rest position.
3. Remove the key and shut the engine OFF.
4. Allow the machine and system fluids to cool.
5. Disconnect the battery power from the machine.

For Reference:

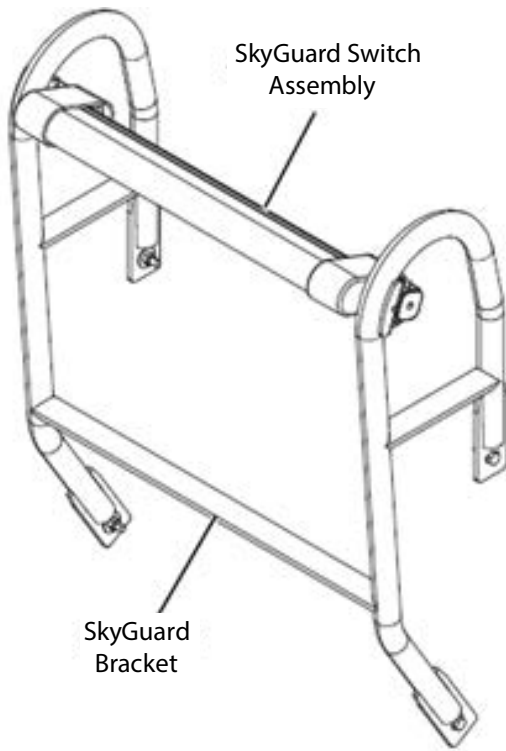

Figure 4-24. SkyGuard Bracket with SkyGuard

Installation:

1. Install the SkyGuard Support Bracket (8) onto the welded mounts on platform rails. Secure the support bracket using four Bolts (2), relevant Washers (7) and Nuts (3). See Figure 4-25.

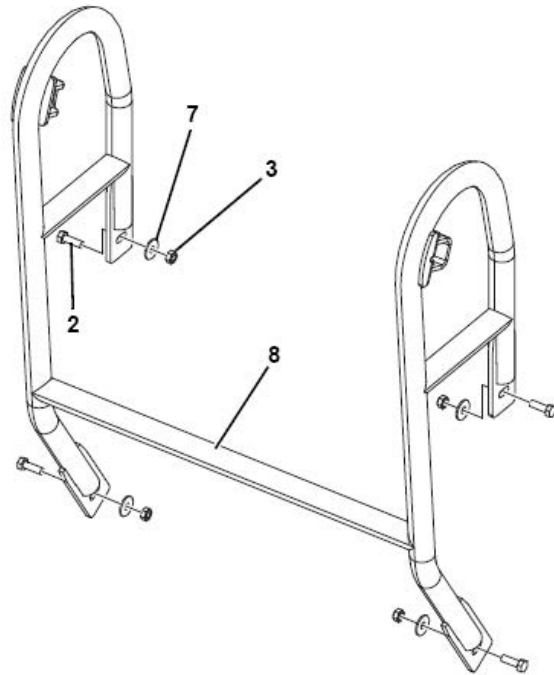

Figure 4-25.

2. Align and attach Platform Sensor Mount (12) onto the SkyGuard Switch (11) as shown in Figure 4-26.
3. Attach Platform Sensor Covers (9) to SkyGuard switch assembly at both ends. See Figure 4-26.

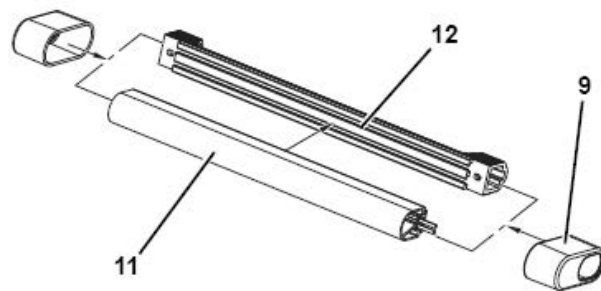

Figure 4-26.

4. Position SkyGuard switch assembly with sensor cover onto the SkyGuard Support Bracket (8) as shown in Figure 4-27.
5. Insert a Shear Block Support (10) through shear block housing on the SkyGuard support bracket and into the platform sensor mount. See Figure 4-27.

NOTE: Ensure the correct position of Shear Block Support (10) before installation.

6. Secure the shear block on welded mount of SkyGuard support bracket using Bolt (1), relevant Washer (6) and Acorn Nut (4) as shown in Figure 4-27.
7. Secure the SkyGuard switch assembly using Bolt (5) and relevant Washer (6) on platform sensor mount. See Figure 4-27.

NOTE: Tighten the Bolt (5) using appropriate allen wrench.

8. Repeat Steps 4 through 7 to secure SkyGuard switch assembly on the other side of the SkyGuard support bracket ensuring correct position of the shear block support before installation.

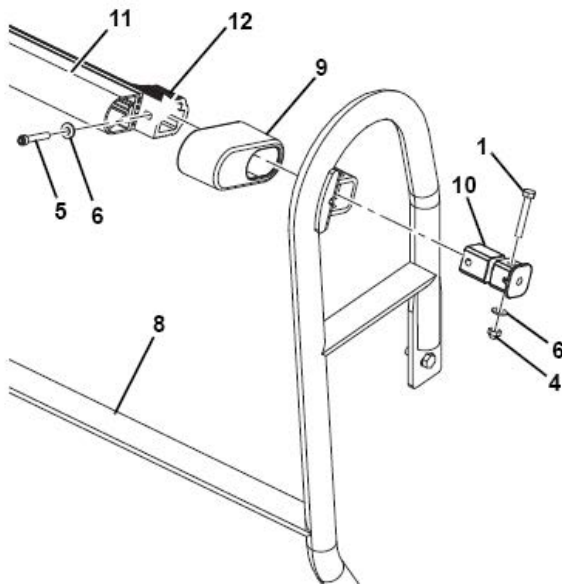

Figure 4-27.

9. Route the SkyGuard switch harness along SkyGuard support bracket (right side) and under the platform control box. Secure the harness using tie straps. See Figure 4-28.

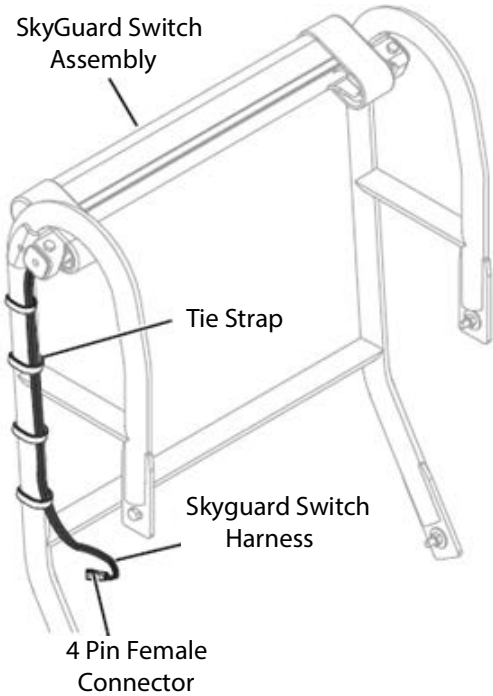

Figure 4-28.

10. Connect Sky Guard connector to the one on the machine located under load cell box. See Figure 4-29.



Figure 4-29.

CAUTION

WHEN THE SKYGUARD IS PUSHED WITH EXCESSIVE FORCE THE SENSOR SUPPORTS (ITEM 10 - FIGURE 4-27.) WILL BREAK. REPLACE WITH NEW SENSOR SUPPORTS BEFORE CONTINUING OPERATION OF THE MACHINE.

11. POWER ON the machine.

- Press button 6 (service) on the remote control
- Press button 7 (set up)
- Press button 5 (password)
- Enter password "4 7 7 1" then press button 9 (OK)
- Press button 3 (extra)
- Press button 1 (optional)
- Press button 8 (next)
- Press button 4 (SkyGuard)
- Press Button 1 (ON)

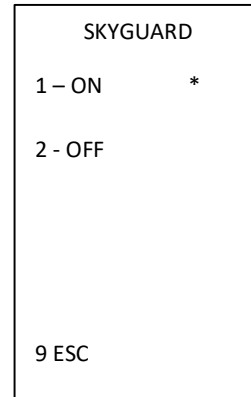

Figure 4-30. Asterisk must show next to the ON position

- Press button 9 (esc)
 - Press button 9 (esc)
 - Press button 9 (esc)
 - Press button 9 (esc)
 - Remote control screen should be on main icon page
- #### 12. Check for the proper functioning of SkyGuard system.

NOTICE

IF PLATFORM REMOVAL WILL BE NECESSARY, SKY GUARD EXTERNAL CONNECTOR HAS TO BE DISCONNECTED. THEN RECONNECTED WHEN THE PLATFORM IS INSTALLED ON THE MACHINE.

NOTE: *If further information is required, please contact the JLG Service Department.*

SkyGuard System

When the SkyGuard sensor is activated, functions that were in use at the time of actuation will reverse or cutout. The table below outlines these functions.

Main Lift (3 Boom) Up	Main Tele (Extension) In	Main Tele (Extension) Out	Main Swing	Drive Forward	Drive Reverse	Tower Lift (1 Boom) Up	Tower Lift (1 Boom) Down	Platform Level	Platform Rotate	Jib Lift
R	C	R	R	C	C	R	C	C	C	C
R= Indicates Reversal is Activated										
C= Indicates Cutout is Activated										

SECTION 5. HYDRAULICS

5.1 GENERAL

The hydraulic components compartment is located on the left side of the machine. Inside the bonnet contains the valve blocks for main boom and aerial control. The deviator valve, the double pump valve, the blow off manifold, the second speed manifold and the hand pump.

The hydraulic tank is pressurized. Every time the hydraulic oil tank is opened (depressurized), such as in case of hydraulic oil filter replacement, it must be pressurized again (with cork screwed) fully extending outriggers and then the booms at turtle mode, to avoid cavitation.

5.2 CHASSIS HYDRAULIC SYSTEM



OL01770

The chassis or "ground part" is controlled by two hydraulic valve blocks (right side and left side), both equipped with

one maximum pressure valve, one proportional valve and an ON-OFF valve for each ground part movement.

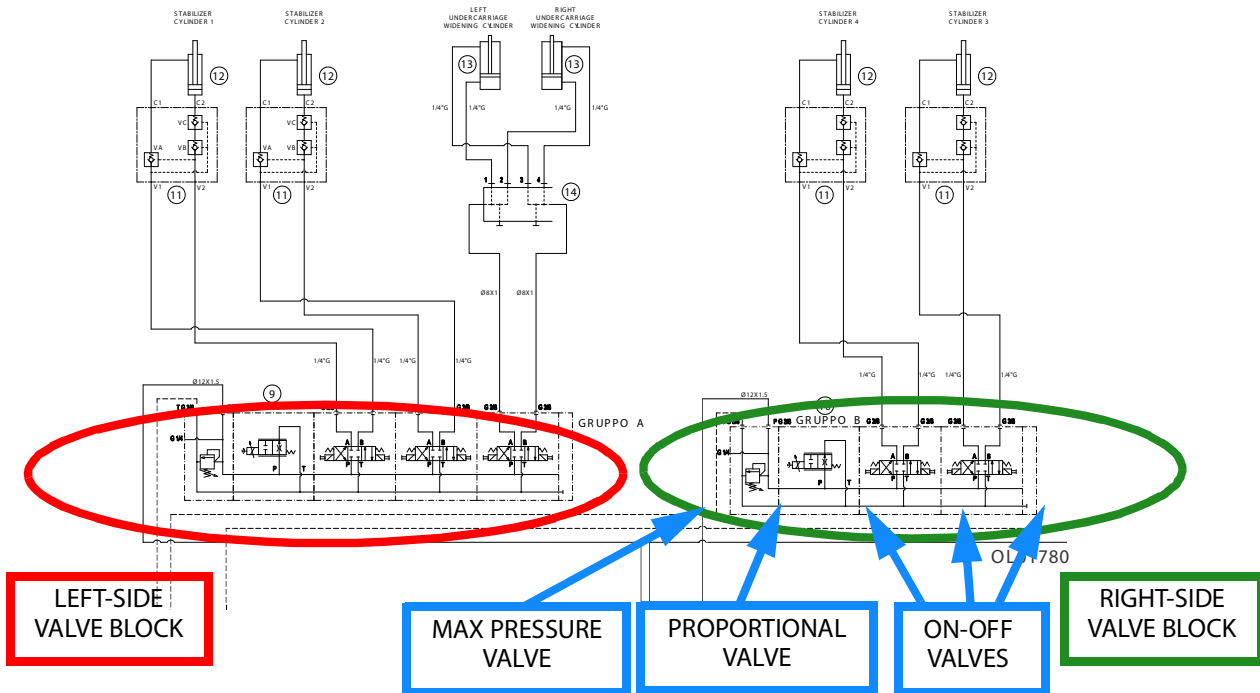
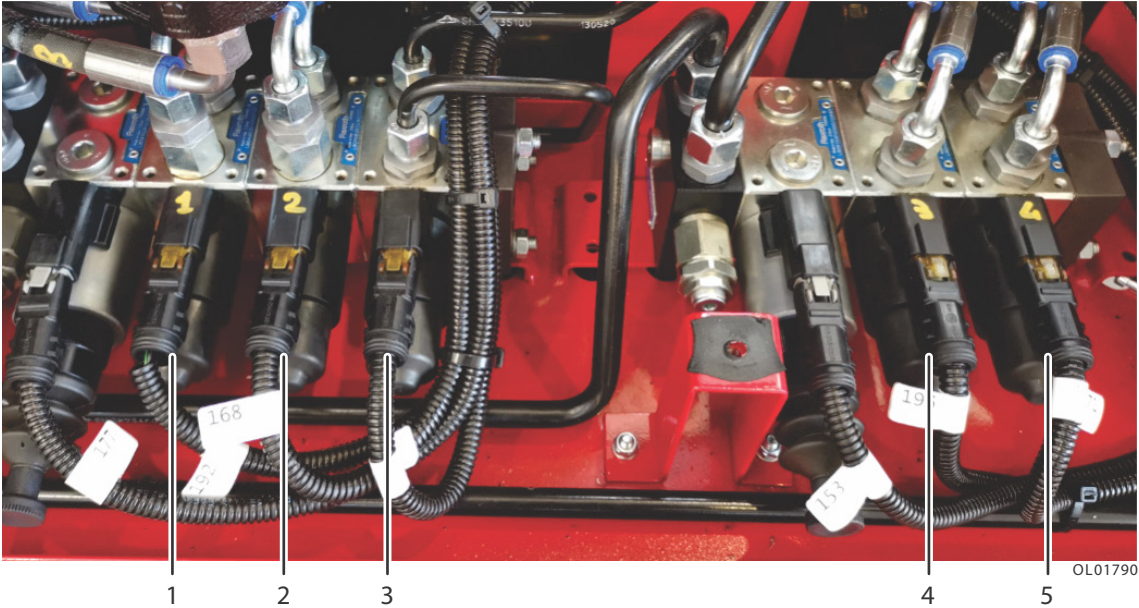

Figure 5-1. Ground Part Hydraulic System Diagram



- 1. Front Left Outrigger
- 2. Rear Left Outrigger
- 3. Tracks Widening System
- 4. Front Right Outrigger
- 5. Rear Right Outrigger

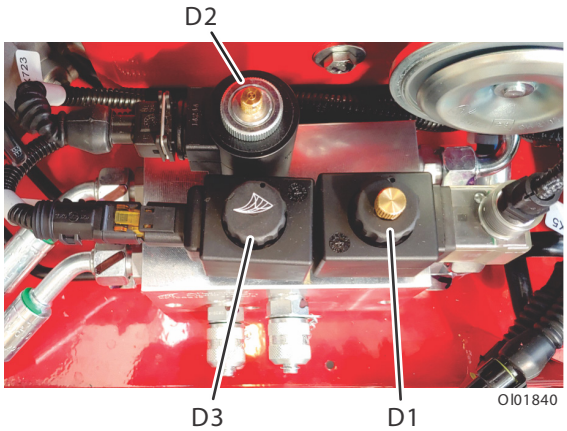
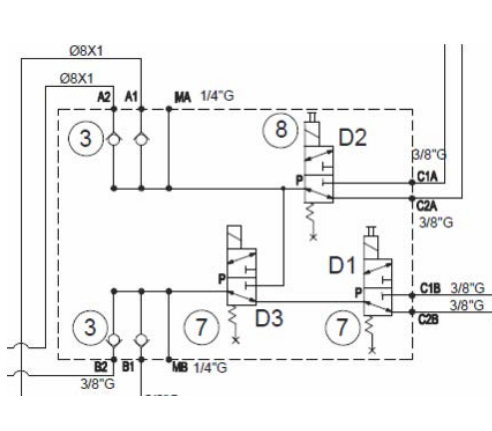

Figure 5-2. Safety ValveBlock

- D1. Right side and main boom
- D2. Left side and aerial section
- D3. Pump sum (feeds D2 line when energized)

On each ground valve block oil rate is controlled through the proportional valve managed by the control module.

Depending on the movement required, proportional valve will open accordingly regulating the oil rate, at the same time the relevant ON-OFF valves (one each movement) will open feeding the relevant cylinder or drive gear motor.

Ground valve blocks maximum pressure valve has to be calibrated at 180 bar with engine running at max speed.

When the proportional valve coil is not energized, oil flows back to the tank.

Left side ground valve block controls the two left side outriggers (n.1 and n.2), the left track drive gear motor and the tracks widening cylinders.

Right side ground valve block controls the two right side outriggers (n.3 and n.4) and the right track drive gear motor.

Outriggers

Outrigger cylinders are controlled by the cylinder valves block that is screwed on the cylinder, when machine is setup on outriggers oil is kept under pressure on the cylinder bottom side, against machine weight, by two piloted one-way valves installed in series on the cylinder valves block. Another piloted one-way valve is installed on the stem side.

While cylinder movements are in progress the opposite/one-way valves is/are piloted to open letting oil flow back to the valve block.

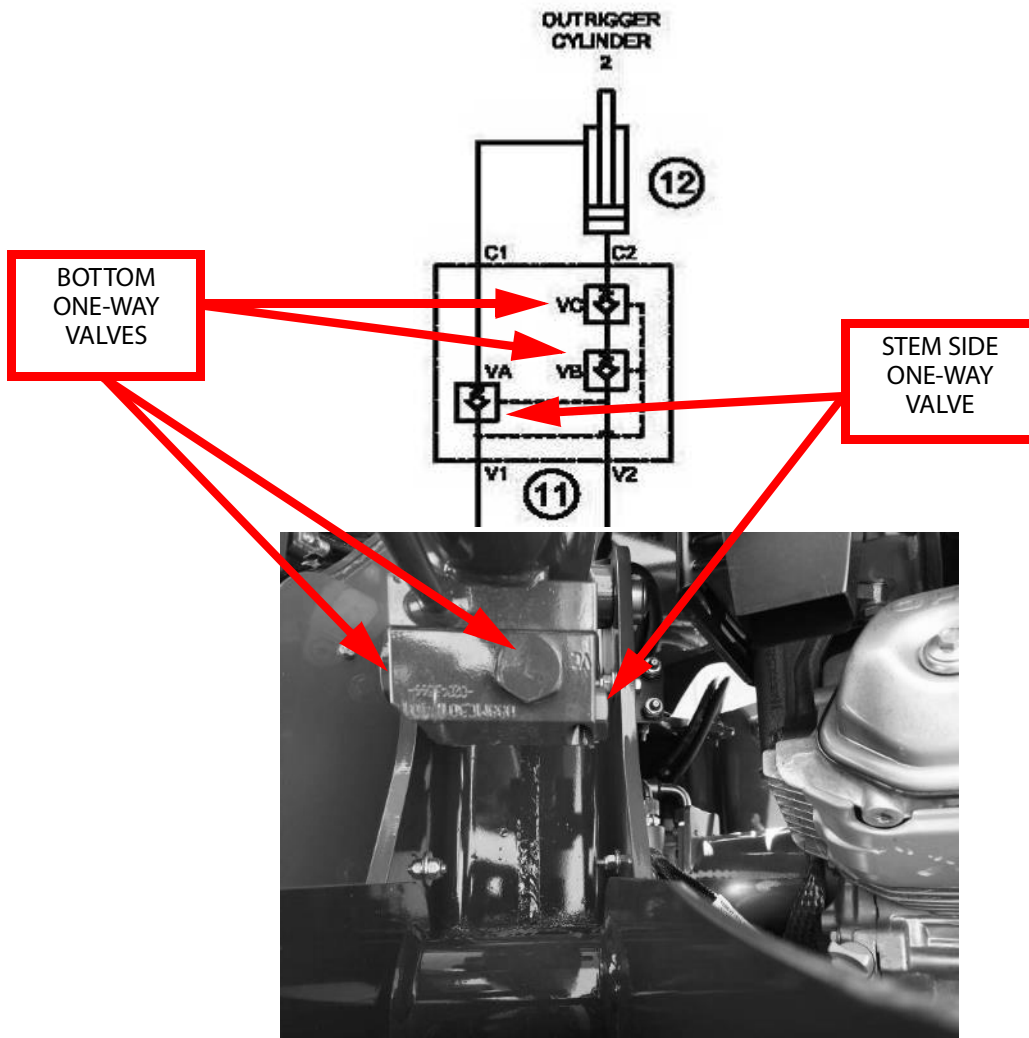

Figure 5-3. Outrigger Cylinder Valve

Tracks Widening

Tracks widening or narrowing is carried out by two cylinders controlled together in parallel by the same valve block element on the left side valve block.

Track widening system oil is sent to both cylinders through the track widening manifold that is installed on hydraulic components compartment.

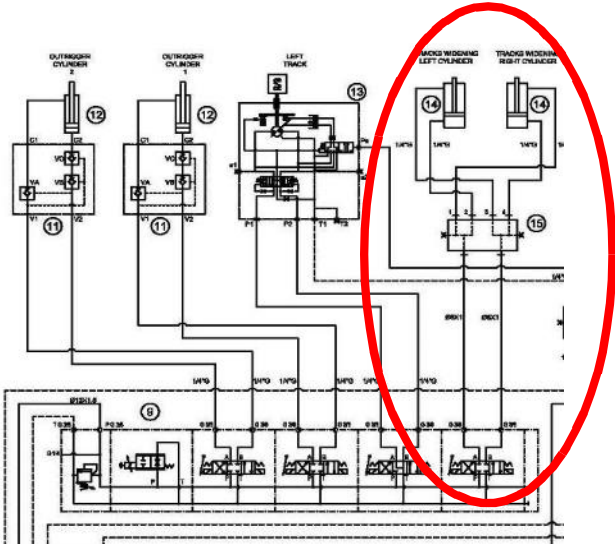
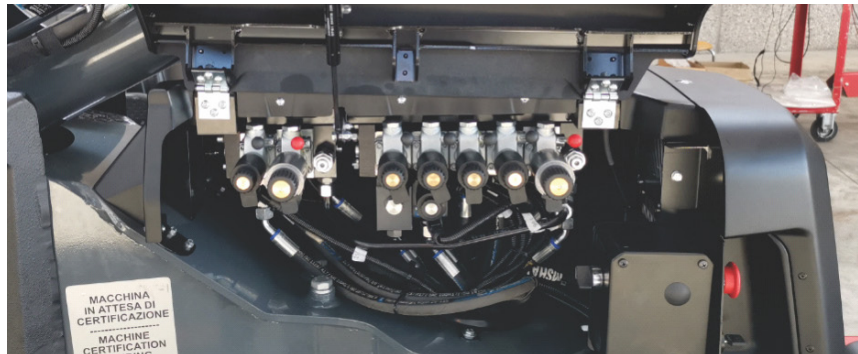

Figure 5-4. Tracks Widening Diagram

5.3 BOOM, PLATFORM & TURNTABLE HYDRAULIC SYSTEM



O101800

The boom, platform and turntable or "aerial part" are controlled by hydraulic valve blocks equipped with one maxi-

mum pressure valve, one proportional valve and an ON-OFF valve for each aerial part movement.

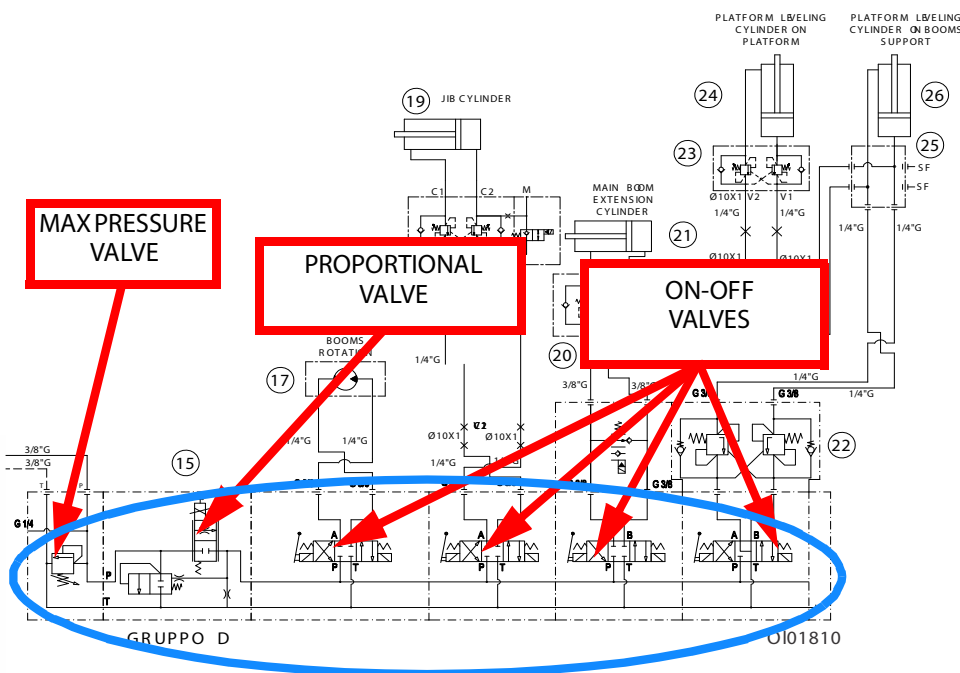

Figure 5-5. Aerial Part Hydraulic System Diagram

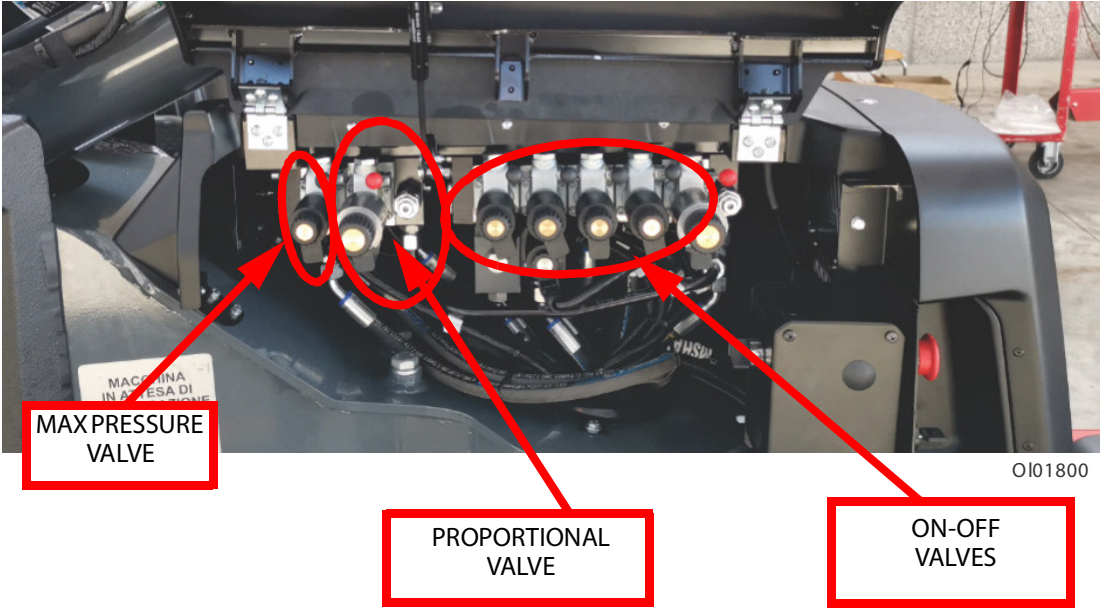

Figure 5-6. Aerial Part Hydraulic System

Aerial part valve block is fed by line "A" through deviator valve and oil rate is controlled through the proportional valve managed by the control module.

Depending on the movement required, proportional valve will open accordingly regulating the proper oil rate, then the relevant ON-OFF valves (one each movement) will open addressing the oil to the relevant cylinder or actuator.

When the proportional valve coil is not fed, oil is sent to the drainage and then to the tank.

The maximum pressure valve has to be calibrated as indicated on use and maintenance manual at 165 bar with engine running at maximum speed.

Through aerial part valve block are fed the turntable rotation motor, the cylinder for moving 1st and 2nd booms, the cylinder for moving the 3rd boom, the telescope cylinder, the jib cylinder, the platform rotation actuator and the platform levelling circuit.

On each cylinder and actuator is installed a couple of calibrated valves, one each direction, when a movement is in progress on one direction the opposite valve is piloted to open letting oil flow back to the valve block.

When these valves are not piloted oil flow is avoided so that they keep the cylinder and actuator position against external forces or in case of an hose damage.

Those valves also help contemporaneity for the main movements.

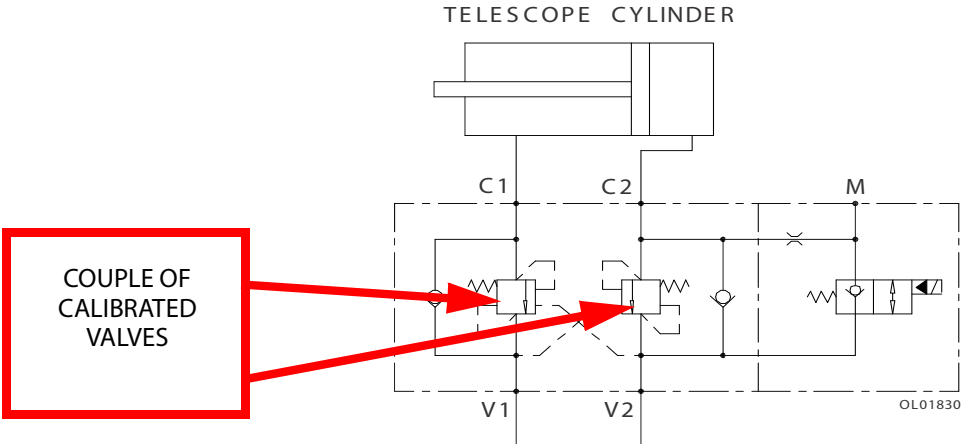

Figure 5-7. Telescope Cylinder Diagram

Telescope

Third boom contains the telescope boom and the telescope cylinder.

Jib

Jib is moved by one cylinder, while moving jib the platform is kept level thanks to the parallelogram system.

Platform Levelling

Platform levelling close circuit is composed by two cylinders, one on the platform and one on the third boom connection rod, platform is automatically kept leveled while third boom is moving because of the platform cylinder is moved by connection rod cylinder.

In particular, while third boom is opening, the connection rod cylinder will be closing so that its oil will be send to the platform cylinder achieving the automatic platform levelling.

Of course is possible to adjust platform levelling acting on its key.

Platform Rotation

Platform rotation is carried out by the platform rotation actuator composed by two chambers, the maximum rotation possible is 62° on both directions achieving a total of 124°.

Two black arrows show the platform aligned position.

Turntable Rotation

Turntable rotation is carried out by a rotation hydraulic motor moved by a worm screw on a bearing ring.

Turntable could be rotated 180° each side till a mechanical block, achieving a total rotation.

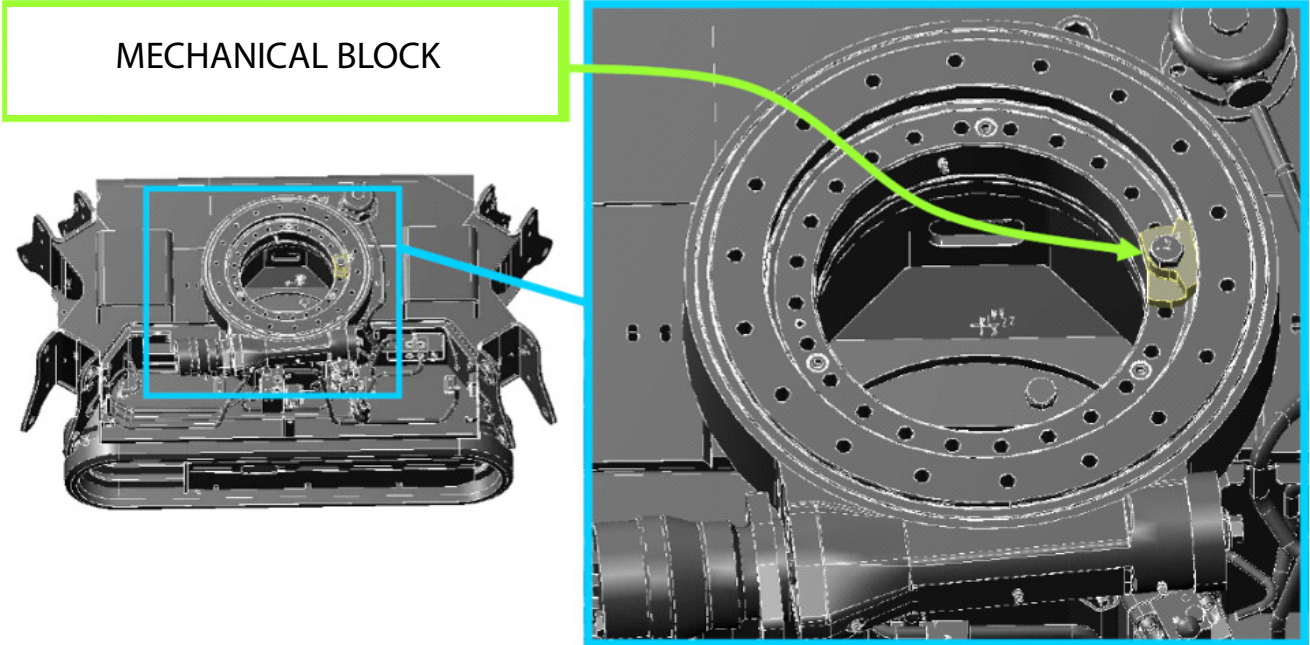

Figure 5-8. Mechanical Block

Emergency Gravity Descent System

Cylinders for 1st and 2nd booms and jib are equipped with a coil valve for gravity emergency descent, they are controlled by the control module when the remote control button "gravity emergency descent" is pressed.

out from the bottom of the cylinder flowing back to the tank (through the ON-OFF valves), so that booms will slow down.

The coil valve for gravity emergency descent has a blue cap.

When they are fed they open a calibrated passage and under the gravity effect (weight) they will allow oil to get



Figure 5-9. Valve for Gravity Emergency

5.4 CYLINDER REPAIR

Specification - Cylinders Overview

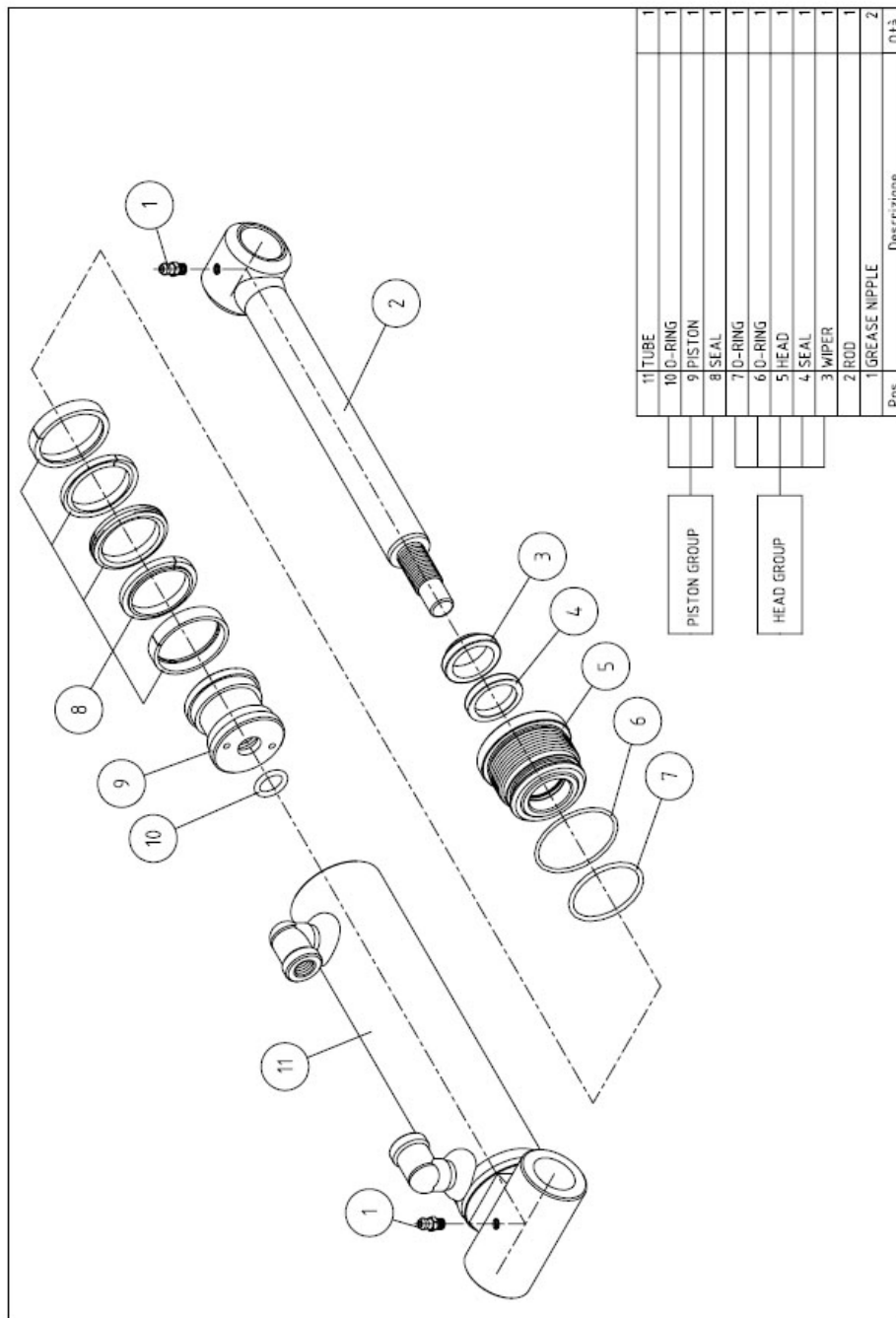

Figure 5-10. Piston Thread

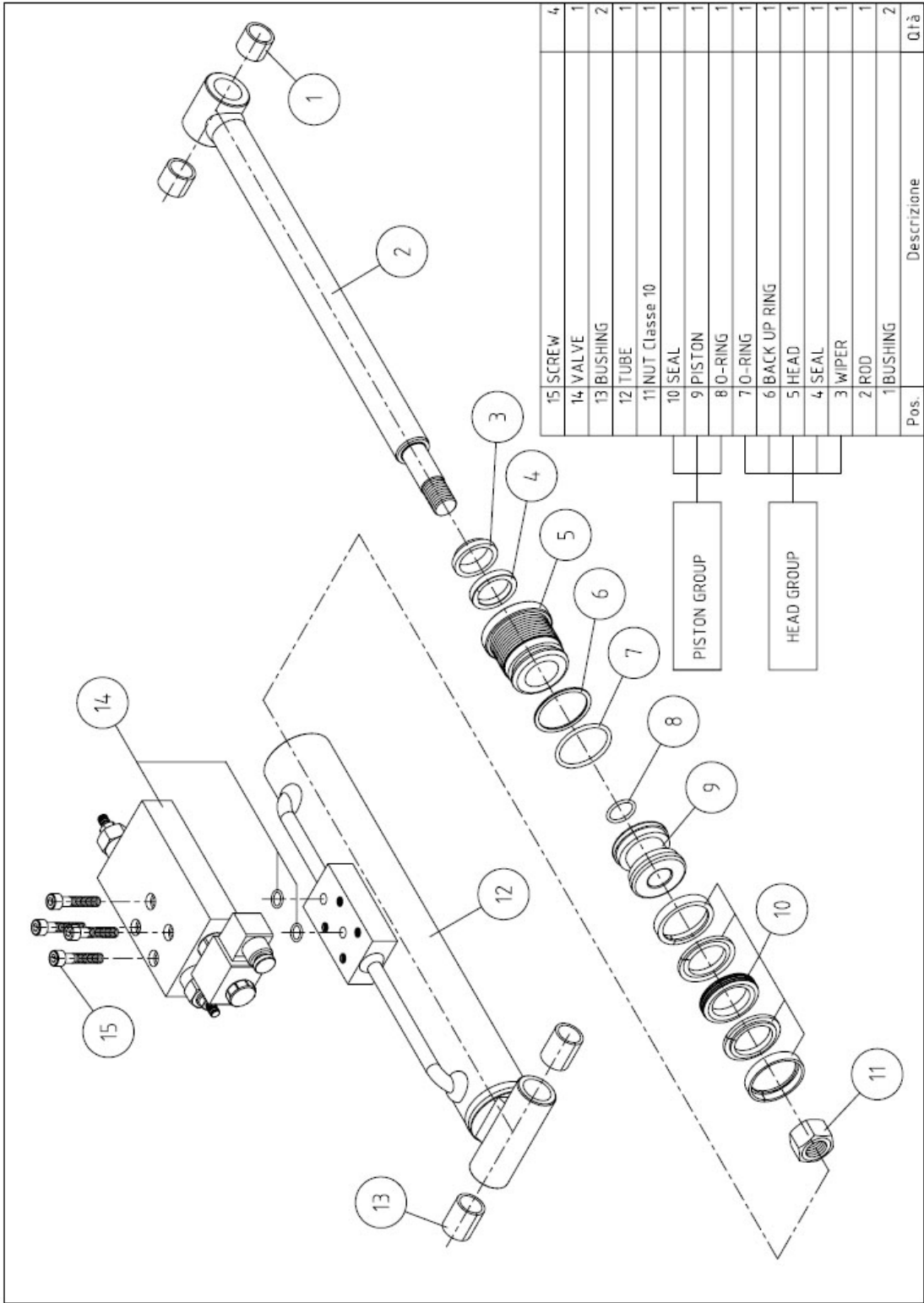

Figure 5-11. Piston With Nut Thread

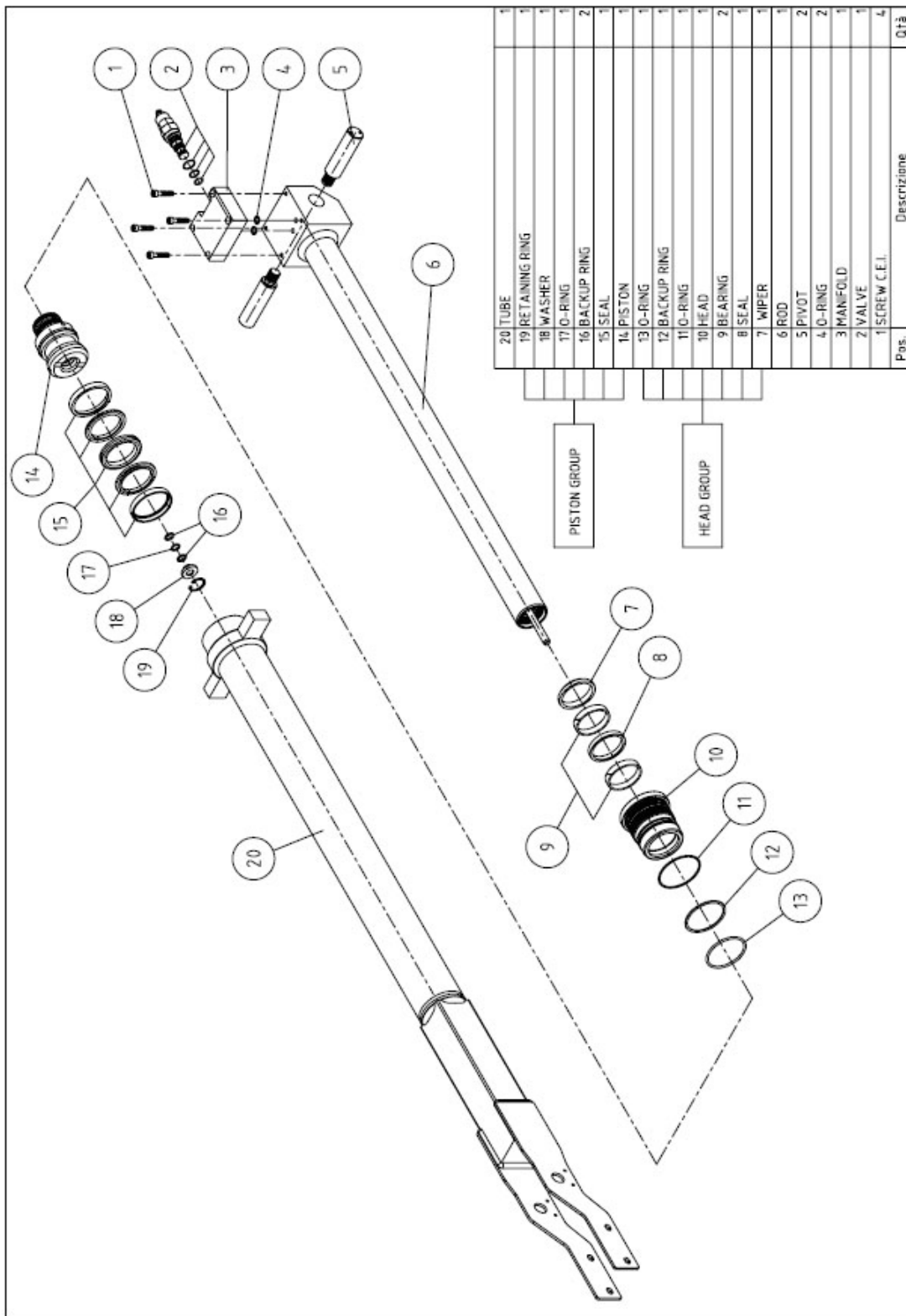

Figure 5-12. Telescope Cylinder

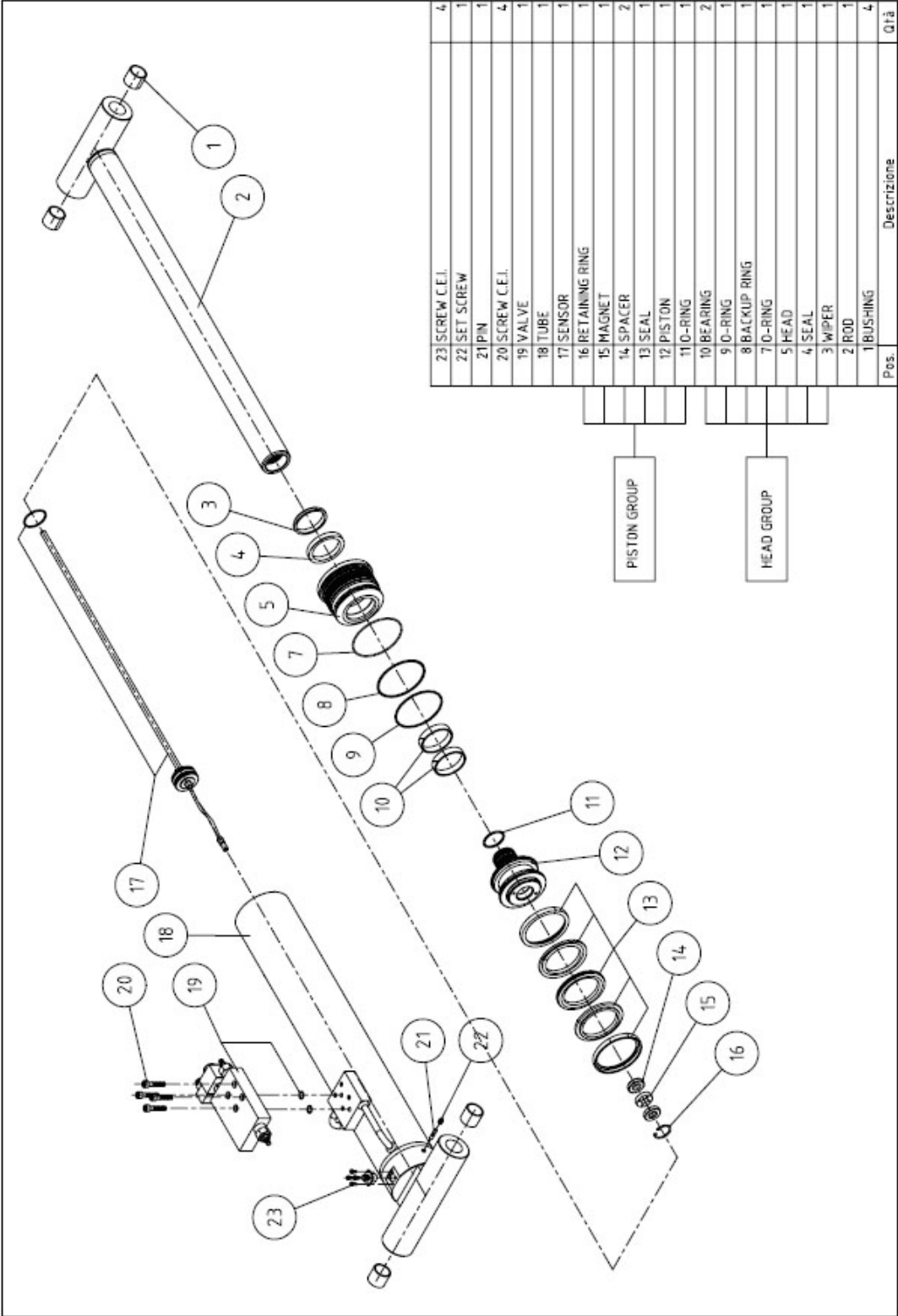

Figure 5-13. Cylinder With Sensor

Hydraulic Cylinders Torque Specifications

Screws Torque Specifications

CYLINDER SCREWS	TORQUE VALUE
DRILLED SCREW 3/8"	70N/m
SCREW M8	25N/m
SCREW M6	11N/m
SCREW M4	3N/m
CAP 1/4"	30N/m
PURGE SCREW	8N/m
GREASE NIPPLE	2N/m
SENSOR SET SCREW	0.5N/m

JUNCTION		
Ø TUBE	METRIC THREAD	TORQUE VALUE (N/m)
6	M12x1.5	20
8	M14x1.5	25
10	M16x1.5	30
12	M18x1.5	40
15	M22x1.5	60
18	M26x1.5	90
22	M30x2	170
28	M36x2	210
35	M45x2	360
42	M52x2	490

TIGHTENING TORQUE HEAD		
HEAD DIAMETER (mm)	TORQUE [Nm]	
	MIN	MAX
30	50	100
35	50	100
40	100	150
45	100	150
50	150	200
55	150	200
60	200	250
65	200	250
70	250	300
75	250	300
80	300	350
90	350	400
100	400	450
110	450	500
120	500	550
130	500	550
140	500	550
150	500	550
160	550	600
170	550	600
180	550	600
190	550	600
200	600	650
210	600	650
220	600	650
230	600	650
240	600	650
250	700	750

Cylinder Assembling

Pay attention to not damage the sensor



NOTICE

WHEN SLIDING THE ROD AND PISTON ASSEMBLY OUT OF THE TUBE, PREVENT THE THREADED END OF THE TUBE FROM DAMAGING THE PISTON. KEEP THE ROD CENTERED WITHIN THE TUBE TO HELP PREVENT BINDING.

1. Screw the head into the cylinder barrel and tighten with a spanner wrench. Refer to "Hydraulic Cylinder Torque Specifications" for tightening guidelines for the head.



2. Thread the counterbalance valve into the block on the cylinder barrel. Refer to "Hydraulic Cylinder Torque Specifications".

NOTE: *The following are general procedures that apply to all of the cylinders without sensor. Procedures that apply to a specific cylinder will be so noted.*

Cylinder Repair Without Sensor

Rod Removal

General Cylinder Disassembly

1. Clean the cylinder with a suitable cleaner before disassembly. Remove all dirt, debris and grease from the cylinder.
2. Clamp the barrel end of the cylinder in a soft-jawed vise or other acceptable holding equipment if possible.



NOTICE

AVOID USING EXCESSIVE FORCE WHEN CLAMPING THE CYLINDER IN A VISE. APPLY ONLY ENOUGH FORCE TO HOLD THE CYLINDER SECURELY. EXCESSIVE FORCE CAN DAMAGE THE CYLINDER TUBE.

3. Remove the counterbalance valve from the side of the cylinder barrel.

NOTICE

DO NOT TAMPER WITH OR ATTEMPT TO ADJUST THE COUNTERBALANCE VALVE CARTRIDGE. IF ADJUSTMENT IS NECESSARY, REPLACE THE COUNTERBALANCE VALVE WITH A NEW PART.

NOTE: *Cylinder can have residual pressure inside.*

4. When the cylinder has been emptied pull out the rod ~ 15mm and loosen the head until ~ 15mm.



NOTICE

WHEN SLIDING THE ROD AND PISTON ASSEMBLY OUT OF THE TUBE, PREVENT THE THREADED END OF THE TUBE FROM DAMAGING THE PISTON. KEEP THE ROD CENTERED WITHIN THE TUBE TO HELP PREVENT BINDING.

Piston With Nut Disassembling

NOTICE

PROTECT THE FINISH ON THE ROD AT ALL TIMES. DAMAGE TO THE SURFACE OF THE ROD CAN CAUSE SEAL FAILURE.

1. Fix the rod into the vice.

NOTE: Before attempting to disassemble the piston remove any accessible seals.

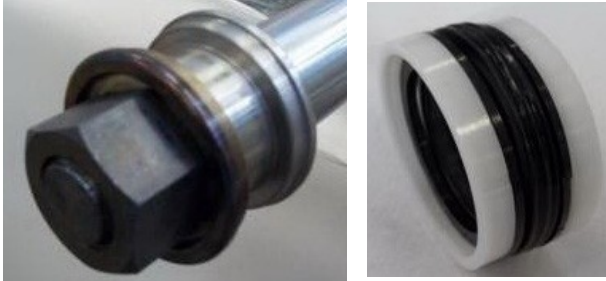

NOTE: Apply heat to break the bond of the sealant between the piston and the rod before the piston can be removed.

CAUTION

WARM THE SURFACE INDICATED MAX 300°C

2. Avoid overheating, or the parts may become distorted or damaged.



Apply sufficient torque for removal while the parts are still hot. The sealant often leaves a white, powdery residue on threads and other parts, which must be removed by brushing with a soft brass wire brush prior to reassembly.

3. Remove the piston head from the rod and carefully slide the head gland off the end of the rod.



Cylinder Assembly

General Cylinder Assembly

1. Use the proper tools for specific installation tasks. Clean tools are required for assembly.
2. Install new seals, backup rings and o-rings on the piston and the head.
3. Fasten the rod eye in a soft-jawed vise, and place a padded support under and near the threaded end of the rod to prevent any damage to the rod.
4. Lubricate and slide the head over the cylinder rod. Install the piston head on to the end of the cylinder rod. Loctite® 243TM and install the set screw in the piston head. Refer to "Hydraulic Cylinder Torque Specifications" for tightening guidelines for the piston, head and the set screws.

Seals Head Replacing

1. Remove all seals, backup rings and o-rings from the piston head and all seals, backup rings and o-rings.



N.	DESCRIPTION	Qty.
1	O-RING	2
2	BEARING	2
3	BACK UP RING	1
4	SEAL	2

2. Install new seals, backup rings and o-rings on the piston and the head using the proper tool.



Cylinder Inspection

1. Inspect internal surfaces and all parts for wear, damage, etc. If the inner surface of the tube does not display a smooth finish, or is scored or damaged in any way, replace the tube.
2. Remove light scratches on the piston, rod or inner surface of the tube with a 400-600 grit emery cloth. Use the emery cloth in a rotary motion to polish out and blend the scratch(es) into the surrounding surface.
3. Check the piston rod assembly for run-out. If the rod is bent, it must be replaced.

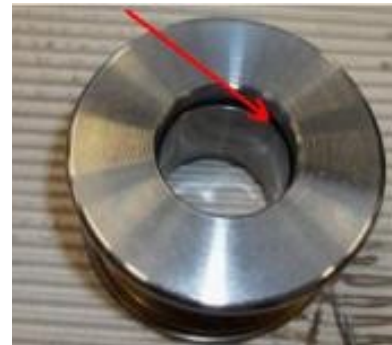

Replace the seals on the piston. DO NOT attempt to salvage cylinder seals, sealing rings or o-rings. ALWAYS use a new, complete seal kit when rebuilding hydraulic components. Consult the parts manual for ordering information.

Mount the seals in the following order:

1. Seal
2. Support bearing
3. Bearing

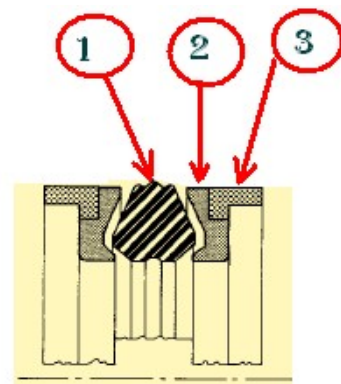

NOTICE

PROTECT THE FINISH ON THE ROD AT ALL TIMES. DAMAGE TO THE SURFACE OF THE ROD CAN CAUSE SEAL FAILURE.

Replace the seals on the piston. DO NOT attempt to salvage cylinder seals, sealing rings or o-rings. ALWAYS use a new, complete seal kit when rebuilding hydraulic components. Consult the parts manual for ordering information.



4. Install the piston on to the end of the cylinder rod. Loctite® 270TM.

NOTE: *If a white powdery residue is present on threads and parts, it can be removed. Clean the residue away with a soft brass wire brush prior to reassembly, and wipe clean before reinstallation.*



Refer to "Hydraulic Cylinder Torque Specifications" for tightening guidelines for the piston.



Bushes Replacement

1. Carefully grind the bush with a milling cutter for plastic.



2. After that the bushing has been removed inspect the internal surface.

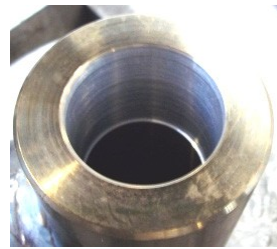

3. Replace the bush with a new one and put it inside with a press.



Emptying Of The Cylinder

Vent Valve

Air inside the circuit has to be removed in order to avoid vibration and irregular motion of the cylinder, vent valves are apply to make this kind of operation.

Failure to remove air from the circuit can cause diesel effect with consequent damage of the seals.

Be sure that there is no presence of air inside the cylinder before it start working.

Purge screw

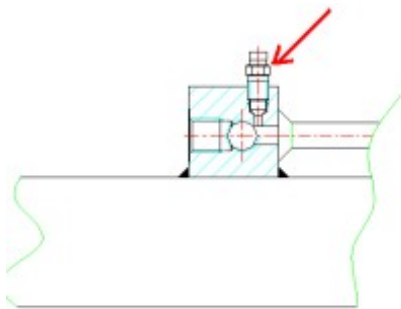

⚠ CAUTION

LOOSEN PURGE SCREW TO LET AIR ESCAPE RE-TIGHTENING TORQUE 6 ft. lbs. (8 Nm).

5.5 REPLACEMENT HYDRAULIC PUMP

Pump Removal

1. Open the top cap of the hydraulic oil tank.
2. Tag & disconnect the hoses from the pump 15.
3. Loose screws 16.
4. Remove from the pump 15 from the adapter 12.
5. Loosen nut 10 and remove the coupling 11 and plate 14 from the pump shaft 15.
6. Move the new pump the particular 14.

Pump Installation

1. Install the plate 14, coupling 11, and the nut 10 on the pump.
2. Tighten the nut 10 at (15Nm).
3. Fit the pump 15 on the coupling 15 with screw 16.
4. Connect the hoses to the pump 15.

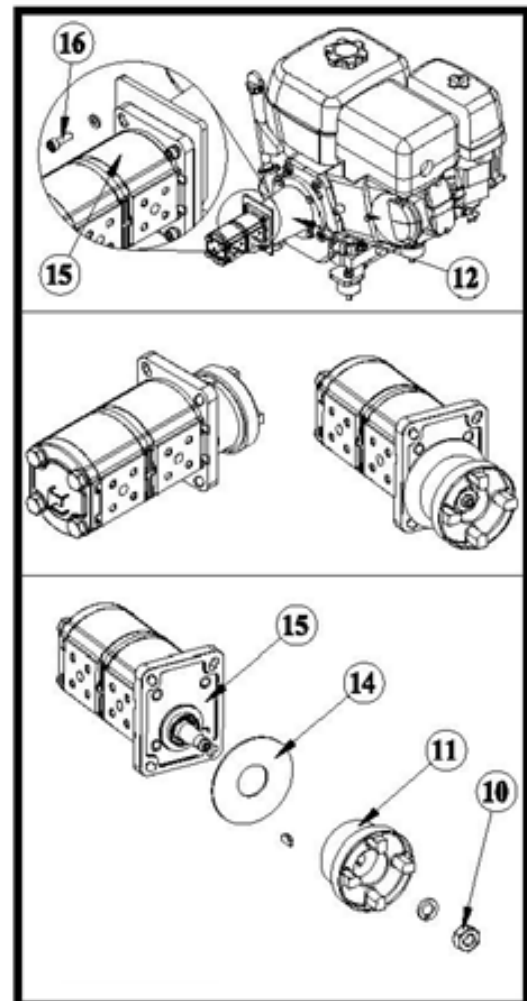

5.6 HYDRAULIC DIAGRAM

Table 5-1. Hydraulic Diagram Index

POS.	DESCRIPTION
1	ENGINE
2	TANDEM PUMP PLP10.3,15-86E1/10.3,15 D/FS-EL (VZN)
3	CHECK VALVE
4	HANDPUMP
5	FILTER
6	DRAINAGES MANIFOLD
7	DIRECTIONAL CONTROL VALVE
8	DIRECTIONAL CONTROL VALVE
9	3 ELEMENTS STABILIZERS AND UNDERCARRIAGE DISTRIBUTOR
10	2 ELEMENTS STABILIZERS DISTRIBUTOR
11	STABILIZER PILOT OPERATED CHECK VALVE
12	STABILIZER CYLINDER
13	UNDERCARRIAGE WIDENING CYLINDER
14	MANIFOLD
15	AERIAL PART 4 ELEMENTS DISTRIBUTOR
16	AERIAL PART 1 ELEMENT DISTRIBUTOR
17	ROTATION MOTOR
18	DOUBLE COUNTERBALANCE W/ EMERG. GRAV. LOWERING
19	JIB CYLINDER
20	DOUBLE COUNTERB. VALVE W/ EMERG. GRAV. LOWERING
21	MAIN BOOM EXTENSION CYLINDER
22	DOUBLE COUNTERBALANCE VALVE
23	DOUBLE COUNTERBALANCE VALVE
24	PLATFORM LEVELING CYLINDER ON PLATFORM
25	MANIFOLD
26	PLATFORM LEVELING CYLINDER ON BOOMS SUPPORT
27	DOUBLE COUNTERB. VALVE W/ EMERG. GRAV. LOWERING
28	MAIN BOOM LIFTING CYLINDER
29	FLOW REGULATOR VALVE

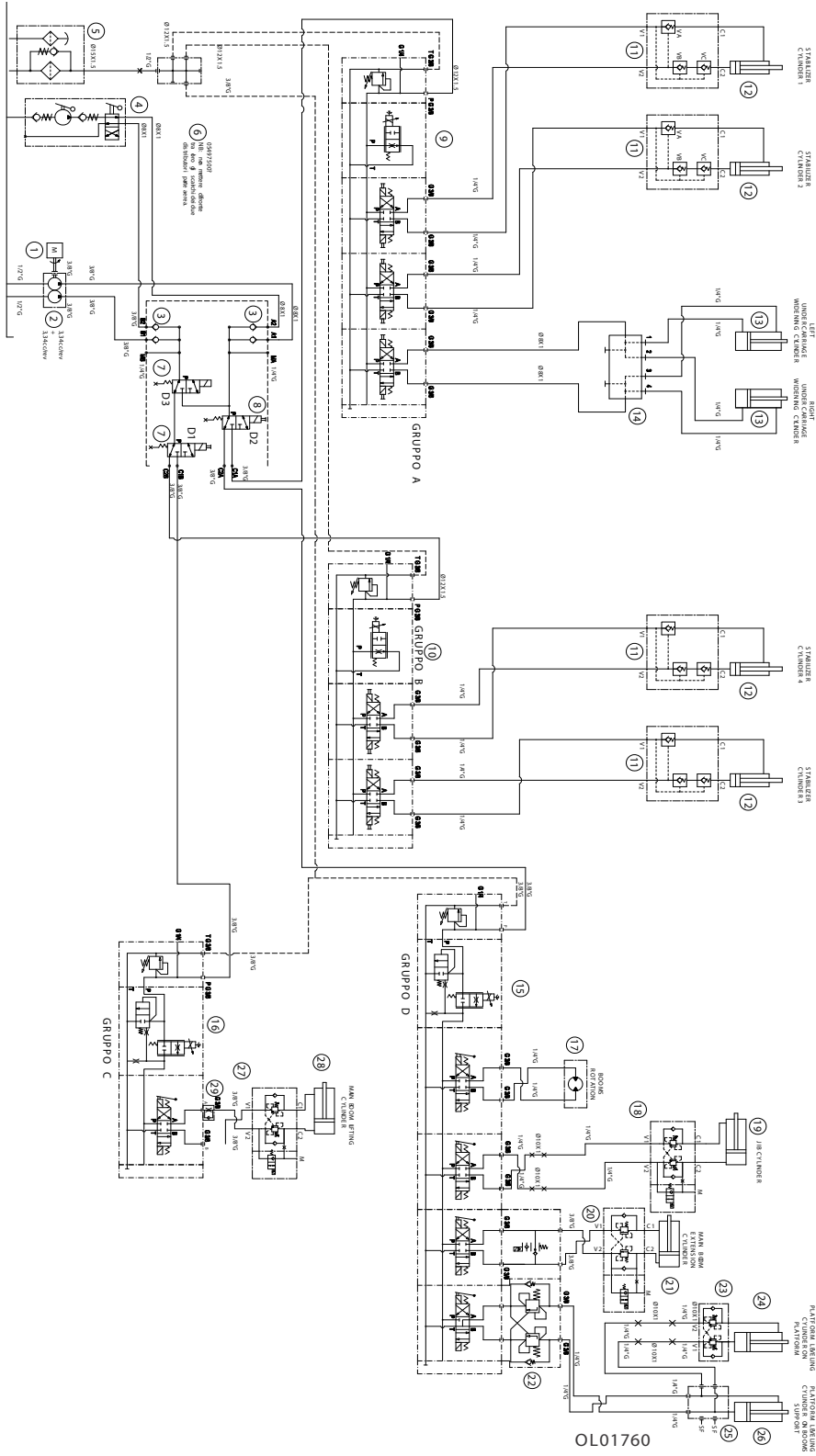

Figure 5-14. Hydraulic Diagram

SECTION 6. JLG CONTROL SYSTEM

6.1 INTRODUCTION

NOTICE

THIS MACHINE IS POWERED BY AN 48 VDC (NOMINAL) ELECTRICAL SYSTEM. BASED ON EMPLOYER, LOCAL, AND GOVERNMENTAL REGULATIONS AS THEY PERTAIN TO THIS MACHINE, SPECIFIC ELECTRICAL TRAINING AND CERTIFICATIONS MAY BE REQUIRED BEFORE SERVICING OR TROUBLESHOOTING.

NOTICE

WHEN INSTALLING ANY NEW MODULE CONTROLLER ON THE MACHINE, IT WILL BE NECESSARY TO PROGRAM THE CONTROLLER FOR THE PROPER MACHINE CONFIGURATION, INCLUDING OPTIONS AND PROPERLY CALIBRATE THE TILT SENSOR.

IT IS A GOOD PRACTICE TO AVOID PRESSURE-WASHING ELECTRICAL/ELECTRONIC COMPONENTS. SHOULD PRESSUREWASHING BE UTILIZED TO WASH AREAS CONTAINING ELECTRICAL/ELECTRONIC COMPONENTS, JLG INDUSTRIES, INC. RECOMMENDS A MAXIMUM PRESSURE OF 750 PSI (52 BAR) AT A MINIMUM DISTANCE OF 12 INCHES (30.5 CM) AWAY FROM THESE COMPONENTS. IF ELECTRICAL/ELECTRONIC COMPONENTS ARE SPRAYED, SPRAYING MUST NOT BE DIRECT AND BE FOR BRIEF TIME PERIODS TO AVOID HEAVY SATURATION.

The JLG Control System is a 12 volt based control unit installed on the compact crawlers boom lift.

The JLG Control System has reduced the need for exposed terminal strips, diodes and trim pots and provides simplicity in viewing and adjusting the various personality

Settings for smooth control of: acceleration, deceleration, creep, min speed, and max. speed for all boom, and drive functions.

The main lift, swing, and drive are controlled by individual Joysticks. To activate Drive, Lift, and Swing move the joystick into the direction desired.

The control system will control the voltage output to the valves, as programmed for smooth operation and maximum cycle time.

The JLG Remote Control has a built in Display and by a push buttons, could show any present faults.

The Remote Control is connected by cable on the following models:

CE - X13SJP / X13SJN

The system can be accessed for troubleshooting even by the analyzer RamHino; kit JLG part no.17162400.

6.2 PLATFORM - REMOTE CONTROL STATION



Figure 6-1. Remote Control



1	3	5	7
2	4	6	8

The display is used to view the status of the machine and the operating information necessary or useful for the operator.

When the machine's main control board is powered, the data are continually sharing between the ECM1 and remote control through the ECM3.

NOTE: Disconnect the remote control only with machine OFF.

Replacing the remote control, the ECM1 board or flashing software, starting machine ON for the first time, the data exchange could take almost one to ten minutes (depending of the software remote control release).

This operation has a variable duration. Normally a few seconds are sufficient, however the following screen may appear on the display:

Turning on the machine and within the operation, the main LCD display screen (Figure 6.1) is activated. There are eight (8) display positions which indicate machine status during various stages of operation.

The remote control is made up of buttons, joysticks, a key selector switch and a display.

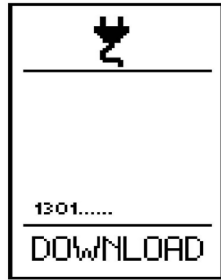

Figure 6-2.

The machine cannot work during this period.
Do not stop the machine or operate it during this period.

NOTE: The numbers shown above DOWNLOAD are the data transferred. The Download will be completed when about more than 20000 steps are transferred.

LCD Display Screen

At machine start-up and during machine operation the main LCD display screen is activated. There are eight (8) display positions which indicate machine status during various stages of operation.

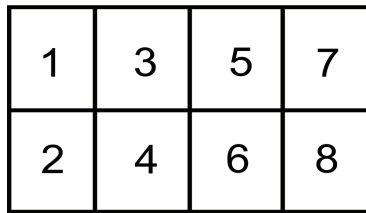

Figure 6-3.

POSITION 1:
Reduced operating area if all outriggers are not fully deployed.

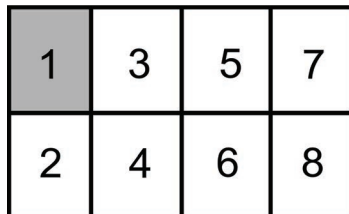

Figure 6-4.

POSITION 2:
Currently unused

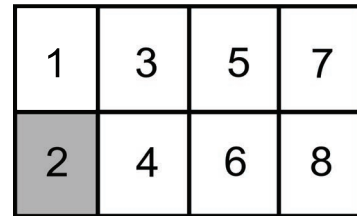

Figure 6-5.

POSITION 3:
Displays if selected engine (diesel or electric) is on or off. The X on the icon indicates the engine is off.

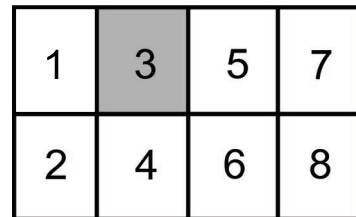

Figure 6-6.

POSITION 4:
Displays selected engine speed.

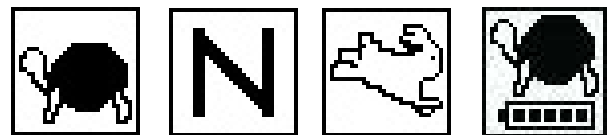
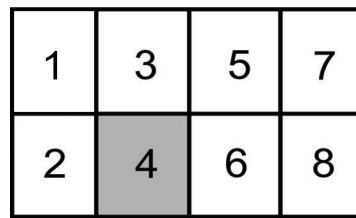

Figure 6-7.

SECTION 6 - JLG CONTROL SYSTEM

POSITION 5:

Displays outriggers are properly set and boom functions are allowed. No display indicates outriggers are not properly set and boom functions are not allowed.

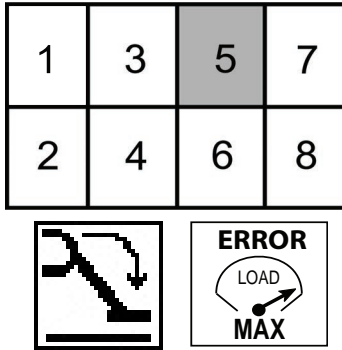

Figure 6-8.

POSITION 6:

Indicates boom, jib, turntable, and base are aligned. Drive, steer, track width adjustment and outrigger functions are operational if this symbol below is present. No symbol indicates these functions are not operational. Drive and steer are operational if all 4 outriggers are not contacting the ground.

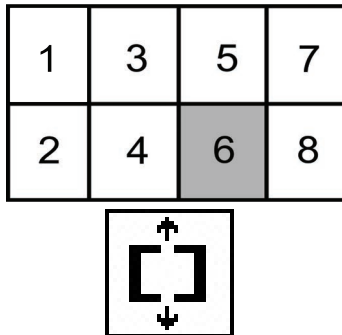

Figure 6-9.

POSITION 7:

Can indicate any of the following situations:

- An emergency stop is pushed in (off).
- A low battery. Batteries need charging by running the gas/diesel engine or connecting to a power source.
- Tower boom sensor is faulty.
- Main boom sensor is faulty. Boom functions are cut out.
- Swing sensor is faulty.
- CANBUS communication is faulty.
- Electronic fault.
- Lithium ION - Signals an error in the BMS - Battery Management System
- Skyguard™ - System Enabled.
- Battery cold/heater activated system is enabled.
- Safety by-pass activated
- Service Interval

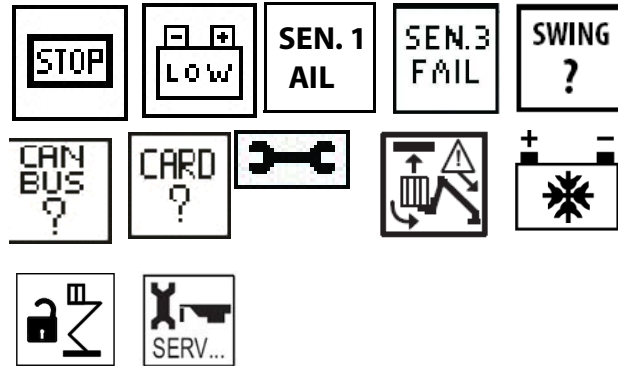
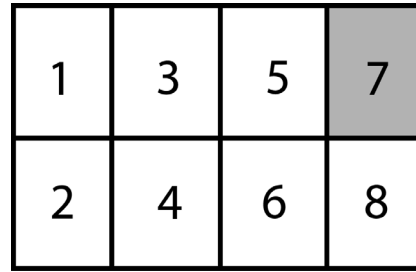

Figure 6-10.

POSITION 8:

- Indicates emergency lowering has been selected.
- Lithium ION - Battery Charge Status and Battery Charger Plugged In.

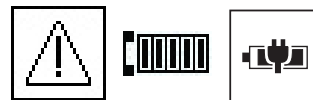
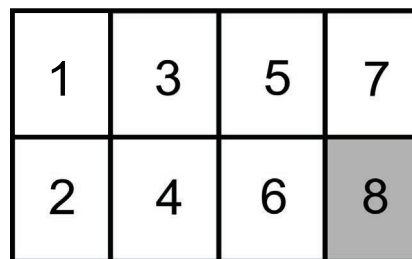

Figure 6-11.

LCD Display Icon Description

The display indicates machine conditions and eventual errors occurred in order to help operator and to have a quick diagnose, here follows icons meanings:













































	Safety state, press and release the remote control stop		Both motors not running		Machine closed and aligned		Close and align the machine
	Engine running		Electric motor running		Lift outrigger from the round		Max tilt angle reached while driving
	Rotate aerial part on the opposite side		Lift 1 st -2 nd booms		Machine stabilized		Max tilt angle reached while stabilizing
	Minimum speed		Standard speed		Maximum speed for tracks		Select which outrigger to move
	Stop button pressed		Unload the basket from its support		Only jib movement allowed		Engine preheating active
	Basket overload		Basket underload		Gravity emergency descent		Movement not allowed by gravity emergency descent
	Machine stabilize error list (*)		12V battery voltage low		Press pedal		Double line sensor error, check error menu
	Error on board input or output, check CODE menu		Software updating in progress		CAN BUS error, check CAN TIME CUT menu		12V battery down or 3 rd boom cable sensor anomaly
	Safeties by-pass activated		Aerial part movements safeties by-pass activated		Undercarriage part movement safeties by-pass activated		Machine fully rotated, rotate few degrees back
	Remote connection in progress		Software updates available		Automatic periodical service reminder		Main key off
	Tilt sensor calibration required		Load cell sensor calibration required		SkyGuard bar pressed		Wrong remote control connection on the basket, at the ground)
	Wrong model elected, the aerial part is not fed						

Figure 6-12. LCD Display Icon Description

Only Lithium Icons

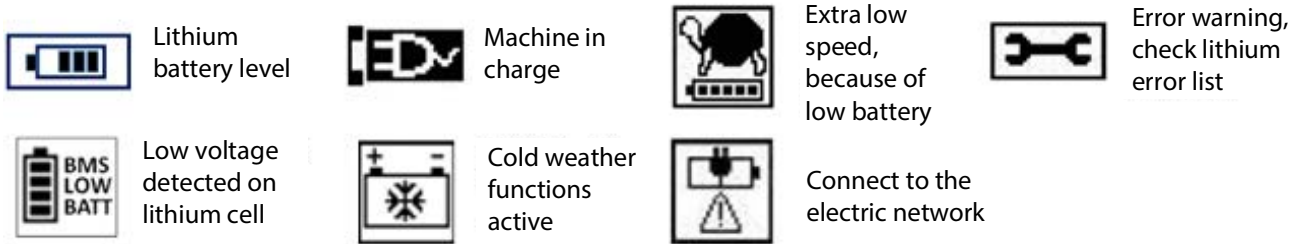

6.3 DIAGNOSTIC BY SERVICE MENU

Further that the icons by the display it's possible to get into diagnostic menus. It's possible to select several languages, the indication here following are for English language.

By diagnostic menus it's only possible to visualize the machine condition, it's not possible to carry out operations such as to modify calibrations or safety parameters of the machine if not after having insert the relevant password.

Pressing button no.6 one time display will show the SERVICE menu.

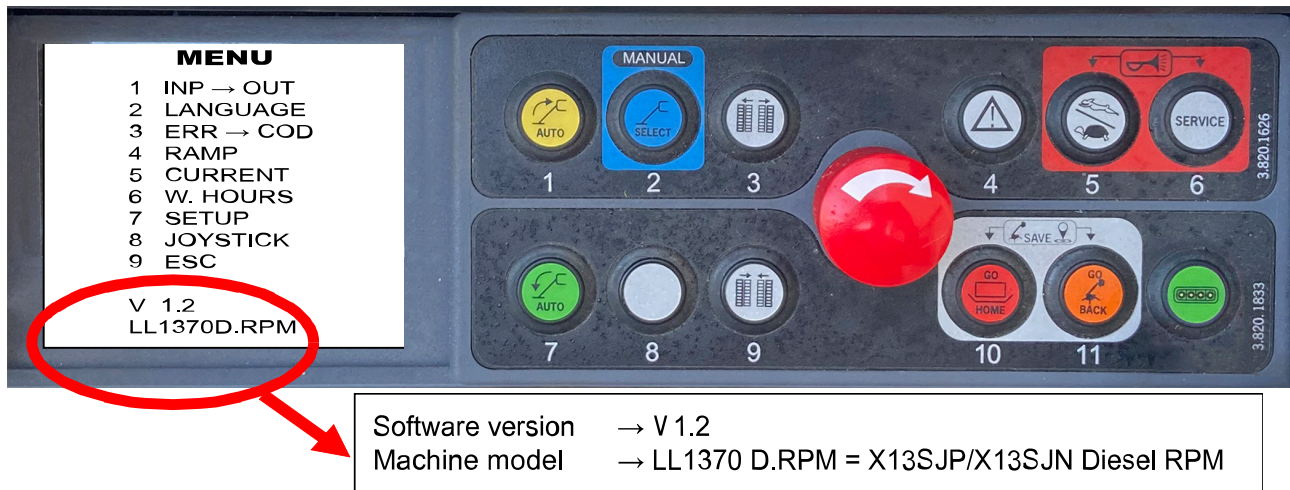

The here above picture shows the SERVICE menu main display, by the lower row it's possible to identify the installed software version and the machine model settled (Gasoline, Diesel or Lithium).

From SERVICE menu pressing button from n.1 to n.8 it's possible to enter into several menus as for instance pressing button n.1 display will show the INPUT menu. Pressing button n.9 (ESC) brings back to the main display.

From SERVICE menu it's possible to enter into other menu and under menus.

NOTE: While into the SERVICE menu it's possible to use all of the joysticks and motors buttons, it's not possible to use outriggers and tracks widening buttons.

Menu Input

This menu visualizes the current status of all the devices giving an input signal to the ECM1, it's so possible to check eventual changes of status.

The device status visualized depends on the signal received by the ECM1 so that it depends on the device itself but also on the connections.

The picture aside shows for instance the status of the first device of INPUT menu. Pressing button n.1 (PREV) brings back to the previous device of the list, pressing button n.2 (NEXT) brings to the next one. Pressing button n.9 (ESC) brings back to the SERVICE menu main display.

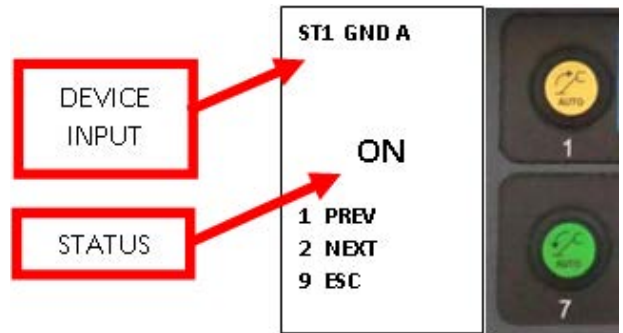

Here follows the INPUT list with their meanings.

ST1GND AB	DOWN DOWN	Outrigger n.1 on the ground - the switch is released, line A is open and line B is closed
	UP UP	Outrigger n.1 lifted - the switch is pressed, line A is closed and line B is open
ST2GND AB	DOWN DOWN	Outrigger n.2 on the ground - the switch is released, line A is open and line B is closed
	UP UP	Outrigger n.2 lifted - the switch is pressed, line A is closed and line B is open
ST3GND AB	DOWN DOWN	Outrigger n.3 on the ground - the switch is released, line A is open and line B is closed
	UP UP	Outrigger n.3 lifted - the switch is pressed, line A is closed and line B is open
ST4GND AB	DOWN DOWN	Outrigger n.4 on the ground - the switch is released, line A is open and line B is closed
	UP UP	Outrigger n.4 lifted - the switch is pressed, line A is closed and line B is open
BYPASAE AB	OFF OFF	The aerial part safeties are deactivated through the safeties by-pass key switch (emergency condition) - line A is closed and line B is open
	ON ON	The aerial part safeties are activated (normal working condition) - line A is open and line B is closed
BYPASCB AB	OFF OFF	The ground part safeties are deactivated through the safeties by-pass key switch (emergency condition) - line A is open and line B is closed
	ON ON	The ground part safeties are activated (normal working condition) - line A is closed and line B is open
EM. GRND AB	ON ON	Stop button on the ground is pressed - line A is closed and line B is open
	OFF OFF	Stop button on the ground is released - line A is open and line B is closed

SECTION 6 - JLG CONTROL SYSTEM

EMRC GND AB	ON ON	Stop button on the remote control ground connected on the ground is pressed - lines A and B of the stop button are open
	OFF OFF	Stop button on the remote control ground connected on the ground is released - lines A and B of the stop button are closed
EM.BASK.AB	ON ON	The stop button on remote control is pressed - lines A and B of the stop button are open
	OFF OFF	The stop button on remote control is released - lines A and B of the stop button are closed
FOTO AB	ON ON	Photocells are aligned with the reflector (machine is closed and aligned) - Photocell A contact is open and photocell B contact is closed
	OFF OFF	Photocells are not aligned with the reflector (machine is not closed and aligned) - Photocell A contact is closed and photocell B contact is open
ST12 CLOSED	ON	Pressure switch of outriggers n.1 and n.2 closes the contact - the outriggers are at end run and the max pressure valve is opened
	OFF	Pressure switch contact of outriggers n.1 and n.2 is opened - the outriggers are open, partially open or already closed
ST34 CLOSED	ON	Pressure switch of outriggers n.3 and n.4 closes the contact - the outriggers are at end run and the max pressure valve is opened
	OFF	Pressure switch contact of outriggers n.3 and n.4 is opened - the outriggers are open, partially open or already closed
TEMP. ALRMA Optional	ON	Temperature external probe reached the maximum value, the temperature probe is closed
	OFF	Temperature external probe hasn't reached the maximum value, the temperature probe is open
GENERATOR (Only for gasoline machine)	ON	Engine is running
	OFF	Engine is not running
EMRG. COMM	ON	The control position selector for aerial part operation from the ground is activated (emergency condition)
	OFF	The control position selector for aerial part operation is released (normal working condition)
START M.TE	ON	The ground button for engine start is pressed
	OFF	The ground button for engine start is released
MOTOR TEMP (Only for Diesel machine)	ON	The engine reached the max functioning temperature (emergency condition)
	OFF	The engine maintains the correct functioning temperature (normal working condition)
MOTOR PRES (Only for Diesel machine)	ON	The engine oil pressure is inadequate (emergency condition)
	OFF	The engine oil pressure is OK (normal working condition)
START M.EL	ON	The ground button for electric motor start is pressed
	OFF	The ground button for electric motor start is released
GND BAS	ON	The control position selector is positioned on "basket" (platform)
	OFF	The control position selector is positioned on "ground"

MICROJIB AB	DOWN DOWN	The JIB is closed - the control switch is released, line A is open and line B is closed
	UP UP	The JIB is open - the control switch is pressed, line A is closed and line B is open
PEDAL AB	ON ON	The pedal is pressed- the pedal electric line A is open and line B is closed
	OFF OFF	The pedal is released - the pedal electric line A is closed and line B is open
R.C. BASKET	ON	The remote control is in the support in basket (platform)
	OFF	The remote control is not in the support in basket (platform)
TRACK OPEN A	ON	Left track is fully widened. Widening cylinder of left track contact is closed
	OFF	Left track is not fully widened. Widening cylinder of left track contact is open
TRACK OPEN B	ON	Right track is fully widened. Widening cylinder of right track contact is closed
	OFF	Right track is not fully widened. Widening cylinder of right track contact is open
INCLIN. X	0.05	Indicates the inclination of the machine on the X axis in degrees
INCLIN. Y	0.3	Indicates the inclination of the machine on the Y axis of degrees
LOAD AB	134 133	Indicates the weight of the platform (about 50 Kg) plus the weight into the platform in Kg measured by A and B lines
POS. 3 ARM	2073	Indicates the opening of the 3rd boom cylinder in tenths of a millimeter
PROXIMITY	ON	Turntable is not almost completely rotated, contact is close, 1st-2nd booms are not above the engine
	OFF	Turntable is almost completely rotated, contact is open, 1st-2nd booms are above the engine
MICR. BR. 1-2	ON	Indicates that 1st boom is not opened enough to rotate above the engine carter
	OFF	Indicates that 1st boom is opened enough to rotate above the engine carter
SKYGUARD	ON	Indicates that Skyguard bar has been pressed.
	OFF	Indicates that Skyguard bar has not been pressed.
MOTOR RPM (Only for Diesel machine)	2220	Indicates the Diesel engine rpm
TEMPERAT.	37,62	Indicates the temperature of the ECM1 in °C
SUPPLY (V)	12,15	Indicates the batteries voltage, or the output voltage from the battery charger

Only Lithium Input

SOC	89	Indicates the charge level of the battery pack, 100% is the maximum, 0% is the minimum
V LITHIUM	40	Indicates the total voltage of the lithium pack. When the cells are not under charge or under discharge, it tends to the nominal value that is around 40 Volt, it doesn't matter their charge status.
A BATTERY	0	Indicates the value of the current (Amp) measured by the LEM sensor. With sign "-" the current is going out from the battery pack (discharge), if there is no sign, the current is going inside the pack (charge)
BMS STATE	1	Indicates the bms status
V MAX CELL	3317	Indicates the voltage at the lowest cell. When the cells are not under charge or under discharge, it tends to the nominal value that is around 3,3 Volt
	2	Indicates the number of the lowest cell
V MED CELL	3316	Indicates the average voltage of the cell. When the cells are not under charge or under discharge, it tends to the nominal value that is around 3,3 Volt
V MIN CELL	3315	Indicates the voltage at the lowest cell. When the cells are not under charge or under discharge, it tends to the nominal value that is around 3,3 Volt
	12	Indicates the number of the lowest cell
BMS A CHG	25	Indicates the maximum current (Amp) that BMS requires to the battery charger (with lithium pack not fully charge)
T MAX CELL	23	Indicates the highest temperature (°C) detected among the cells
	2	Indicates the number of the temperature sensor with the highest temperature detected
T MED CELL	23	Indicates the average temperature (°C) detected among the cells
T MIN CELL	23	Indicates the lowest temperature (°C) detected among the cells
	1	Indicates the number of the temperature sensor with the lowest temperature detected
T BMS	27	Indicates the temperature (°C) detected on the BMS
SOH	98	Indicates the state of health of the battery pack; it indicates how much the battery pack could perform
B CAPACITY	80	Indicates the remaining capacity (Ah)
R MAX CELL	1	Indicates the highest resistance (mOhm) of the cells
	1	Indicates the number of the cell with the highest resistance
R MED CELL	1	Indicates the average resistance (mOhm) of the cells
R MIN CELL	1	Indicates the lowest resistance (mOhm) of the cells
	1	Indicates the number of the cell with the lowest resistance
HOURS INV	27	It counts the working hours with engine running
RPM INV	0	Indicates the engine rpm read by the engine rpm sensor. At a certain rpm setting, the rpm read depends also on the electric load

Language Menu

Through this page it is possible to select the visualization language among ITALIAN, GERMAN, ENGLISH, FRENCH and SPANISH. To change the language has to be press the relevant button number and button n.9 to come back to the SERVICE menu main display



Error Menu

By ERROR menu pages are displayed the eventual current errors, an error occurs when a double line device has one line signal not coherent with the other.

The most of the machine double line devices, all except remote control emergency stop button have one line closed (NC) and one line opened (NO).

A part for the remote control emergency stop button, when the two lines are both opened or both closed, there's an error in progress and the icon HELP ERROR will appear on the display.

In that case into the ERROR menu the involved device reference will be marked aside with a "NO" instead of an "OK".

ERROR menu is composed by the following 5 different pages selectable by buttons n.1 and n.2, it's always possible to come back to the SERVICE menu main display pressing button n.9.

When a device reference is marked with a "NO" that means there's an error and that device has one line signal not coherent with the other.

PAGE 1

ERRORS	
ST1 GND	OK
ST2 GND	OK
ST3 GND	OK
ST4 GND	OK
1	PREV
2	NEXT
9	ESC

ST1 GND	Outrigger n.1 on the ground switch
ST2 GND	Outrigger n.2 on the ground switch
ST3 GND	Outrigger n.3 on the ground switch
ST4 GND	Outrigger n.4 on the ground switch

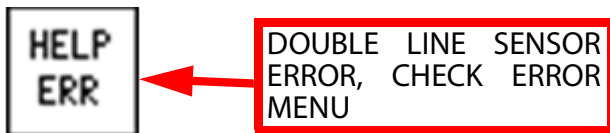

SECTION 6 - JLG CONTROL SYSTEM

PAGE 2

ERRORS	
BYPASA	OK
BYPASC	OK
EM.GRN	OK
EM. RC B	OK
EM. RC G	OK
FOTO	OK
PEDAL	OK
SKYGUARD	OK
1 PREV	
2 NEXT	
9 ESC	

BYPASA	Aerial part safeties by-pass switch
BYPASC	Ground part safeties by-pass switch
EM. GRN	Stop button on the ground
EM. RC B	Remote control stop button in basket (platform)
EM. RC G	Remote control stop button on the ground
FOTO	Photocells
PEDAL	Pedal
SKYGUARD	SkyGuard system

PAGE 3

ERRORS	
MICRJIB	OK
INCL	OK
LOAD	OK
CODE	OK
1 PREV	
2 NEXT	
9 ESC	

MICRJIB	Jib opening switch
INCL	Machine inclination sensors
LOAD	Platform load cell sensor
CODE	Do not consider

PAGE 4

The fourth and fifth pages inform about an eventual error on CAN BUS system indicating the component involved. All of the components should be marked with an "OK", in case of a "NO" it means that component it's not properly communicating through CAN BUS.

CAN TIMOUT	
REMOTE	OK
CIL3	OK
INCL	OK
48XS B	OK
MODEM	OK
1 PREV	
2 NEXT	
9 ESC	

REMOTE	Remote control
CIL3	3RD boom cylinder position sensor
INCL	Machine inclination sensors
48XS B	Load cell board (ECM3)
MODEM	Modem
SKYGUARD	SkyGuard system

PAGE 5

LITH ERR	
BATT:	0
INVER:	0
CARIC:	0
1 PREV	
2 NEXT	
9 ESC	

The fifth page has to be considered only for Lithium machines, BATT, INVER and CARIC are indicated as "0" otherwise it means there's a Lithium error in progress.

More information about those data are detailed on the Lithium Manual.

Working Hours Menu

This page indicates the machine working hours displaying engine working hours and electric motor working hours.

On Lithium machines have to be considered only the electric motor hours.

For both models "KEY" indicates the hours with main key switched ON.

Press button 6 "W.HOURS".

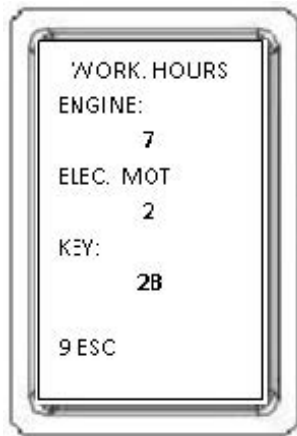

Working hours to reset/modify:

1. Press button 7 "SETUP".
2. Press button 5 "PASSWORD".
Using the remote control buttons to enter the password 7385.

NOTE: Passwords allow changing the Working Hours of Engine and Electrical Motor.

Once the correct password is accepted the display showed "OK".

3. Press button 9 "ESC" two times.

NOTE: Repeat the above steps if "NO" appear on the display.

4. Press button 6 "W:HOURS".
KEEPING PRESSED the button 6 use the button 1 "T+" to increase and button 2 "T-" to decrease the working hours of the ENGINE.

KEEPING PRESSED the button 6 use the button 7 "E+" to increase and button 8 "E-" to decrease the working hours of the Electric Motor.

KEEPING PRESSED the button 6 and then button 3 to set zero the working hours of Engine and Motor.

5. Press button 9 ESC 3 times to escape.

On Lithium models the Engine working HOURS will stay always 0.

The procedure to view or change the working Hours of the electrical motor are the same as per double powered models.

Joystick Menu

By this page it's possible to verify the proper functioning of the joysticks, once selected one joystick by buttons n.1 and n.2, joystick enumeration is indicated here below, the display will show its position, expressed in step from 0 (rest position) to 127 (joystick fully pressed up or down).

Moving the selected joystick it's so possible to check its proportionality and its end of the stroke (about 127 steps) both forward and backward.

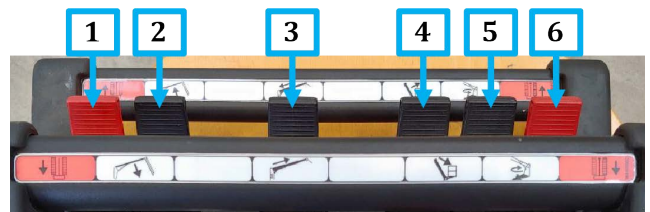

6.4 MACHINE SETUP MENU

From the SERVICE menu, pressing button 7 "SETUP" accesses the menu SETUP to adjust the parameter settings in order to achieved proper machine performance.



When selection the machine model to match the size of the machine, the personality settings will all default to the factory recommended setting.

NOTE: Passwords will give you access to level, which will permit you to change all machine settings.

NOTE: Refer to the following steps in this Service Manual for the recommended factory settings.

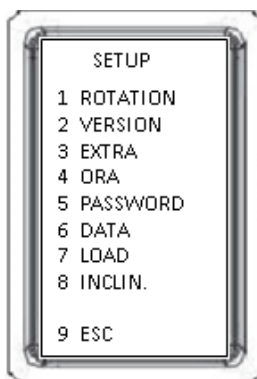

Setup - Version

By this page is visualized the currently installed machine model and power supply version.

After having inserted the relevant password "3684" by this page it's possible to set machine model pressing button n.1, and to set power supply version pressing button n.7.

After this setting machine need to be REBOOT by the main key reset

```

VERSION

MODEL:
LL1570
ENGINE:
G.13L

1 MODEL
7 ENGINE
3 SAVE
9 ESC
    
```

Setup - Password

Some setting requires a password, some passwords are relevant to more than one setting, some other passwords are dedicated to only one setting.

By PASSWORD page it's possible to insert the password required pressing the keyboard buttons, password are composed by 4 numbers, if password is accepted display will visualize an "OK".

```

PASSWORD

0
0
0
0

9 ESC
    
```

Setup - Time

By this page is visualized the settled time, after having inserted the relevant password "8262" it's possible to choose the time-zone pressing buttons n.1 or n.2, ZONE: 0 is the time in meridian "0".

```

TIME

8 : 34 : 05

ZONE: 2

1 ZONE. +
7 ZONE. -

9 ESC
    
```

Setup - Date

By this page is visualized the settled time, after having inserted the relevant password "1468" it's possible to adjust it, pressing buttons n.1 to modify the day, buttons n.2 to modify the month and n.3 or n.4 to modify the year.

```

DATE

5 11
2016

9 ESC
    
```

Setup - Load Cell Board (ECM3) Calibration

After having replaced the master board (ECM1) or the load cell board (ECM3) or having replaced the load cell sensor it's necessary to calibrate the "0" of the load cell system, by this procedure the calibration parameters relevant to the load cell sensor installed will be memorized on the ECM1.

Being possible difference between one load cell sensor and another it's necessary to calibrate ECM1 with the load cell sensor installed on the machine and not with another.

The load sensor system reset must be done with the platform unloaded from its support.

The reset the load sensor system consist into saving the value "0", done without the platform, here follows the calibration procedure:

1. Turn ON the main key and stay out from the platform with remote control on hands.
2. Press button n.6 (SERVICE) and then press button n.7 (SETUP).
3. Press button n.5 (PASSWORD). The display will ask for the password.
4. Inserting password 6138 the display will confirm with "OK".
5. Press button n.9 (EXIT) and then button n.7 (LOAD SENS), the display will than visualize the page here below:

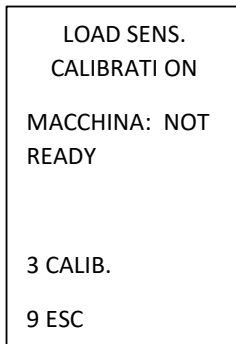

6. With the platform unloaded from its support press button n.3 (CALIB) and verify that display indicates "OK". In case of the platform is still loaded on its support this page will display "NOT READY" instead of "READY" and reset will not be possible.
7. Press button n.9 (ESC) and then turn OFF the main key.
8. Turn ON again the main key and verify by INPUT "LOAD A" and "LOAD B" that calibration is correct by checking the variation at several platform loading condition, the difference between LOAD A and LOAD B values should be less than a certain value.

Setup - Acceler (Calibrating Tilt Sensor)

This menu allows the calibration of the tilt sensor.

After replaced the master board (ECM1) or the tilt sensor it's necessary to calibrate the tilt levelling system.

NOTE: Ensure the tilt switch is mounted at distance of 15 mm and securely attached on the bracket plate, with the screws 5x45 TCEI and Loctite.

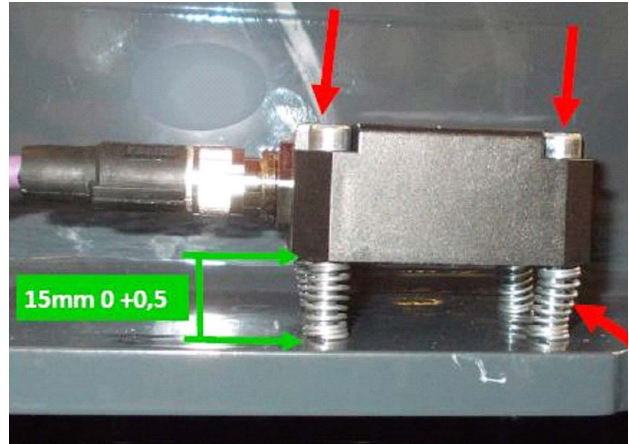

NOTICE

A NEW TILT MODULE WILL ACT AS IF IT IS TILTED ALL OF THE TIME UNTIL THE FOLLOWING PROCEDURE IS PERFORMED.

WARNING

DO NOT CALIBRATE THE LEVEL SENSOR EXCEPT WITH A MACHINE LEVELLED. PLACE THE MACHINE ON OUTRIGGERS, WITH BOOMS IN STOWED POSITION AND ALIGNED WITH THE PHOTOCELLS AND THE PLATFORM EMPTY. ENGINE AND ELECTRICAL MOTOR MUST BE SWITCHED OFF (AVOIDING VIBRATIONS).

Start of the calibration procedure:

1. Turn ON the main key and wait for display switching ON.
2. Press button n.6 (SERVICE) and then press button n.7 (SETUP).
3. Press button n.5 (PASSWORD). The display will ask for the password.
4. Inserting password 2857 the display will confirm with "OK".
5. Press button n.9 (EXIT) and then button n.8 (INCLIN.), the display will than visualize the page here below.

```

INCLINATION
SENS. CA
LIBRATION

MACCHINA: NOT
READY

3 CALIB.

9 ESC
    
```

Press button n.3 (CALIB) and verify that display indicates "OK". In case of outriggers are not touching the ground, or photocells are not aligned, engine or electrical motor is switched on, this display will show "NOT READY" instead of "READY" and reset will not be possible.

6. Press button n.9 (ESC) and then turn OFF the main key.
7. Turn ON again the main key and verify at INPUT "INCLIN. X" and "INCLIN. Y".

To verify the calibration is accurate, test out the values at different machine gradient position.

Setup - Extra

EXTRA menu gives the access to other settings and under menus.

The here aside picture shows the EXTRA menu display, from EXTRA menu pressing button from n.1 to n.6 it's possible to enter into further pages. Pressing button n.9 (ESC) brings back to the SETUP menu.

```

EXTRA

1 OPTIONAL
2 FIRMWARE
3 CARDS
4 MODEM
5 GPS

9 ESC
    
```

Setup - Extra - Modem

This page could be used in case of RAHM difficult connection; the meanings of the parameters shown by this page are the followings.

- STATUS: INIT. --> Initialization, modem is not ready to communicate.
READY --> Modem is ready to communicate
- SIM: NO --> SIM CARD not present (STATUS will be INIT.)
OK --> SIM CARD present
- OPERATOR: Shows the network operator, for instance TIM
- RSSI: 0 - 100 --> SIM CARD operator signals, need to be over 50 to have a good connection
- BER: 0 - 100 --> network line signals
- GPRS: Ok --> GPRS signal available

```

MODEM

STATUS :
READY
SIM OK
OPERATOR
I TIM
RSSI : 75
BER : 70
GPRS: Ok

9 ESC
    
```

Setup - Extra - GPS

This page shows RAHM references, the position availability, latitude and longitude, date and hours references

```

GPS

FIX: OK
LATIT.:
45,20
LONGI.:
11,03

9 ESC
    
```

Optional (Page1)

OPTIONAL menu gives the access to other settings.

The here aside picture shows the OPTIONAL menu first page display, from which pressing button from n.1 to n.6 it's possible to enter some settings.

Pressing button n.8 it's possible to enter into a second page of settings, shown below.

Pressing button n.9 (ESC) brings back to the EXTRA menu.

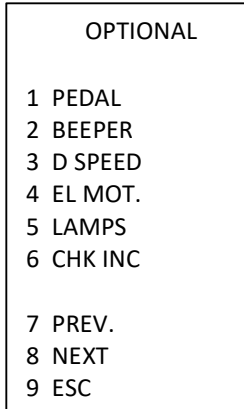

Pedal

By this page it's possible to set the pedal, after having inserted the relevant password "4771", pressing button n.1 "ON" pedal will be activated, pressing button n.2 "OFF" pedal will be deactivated.

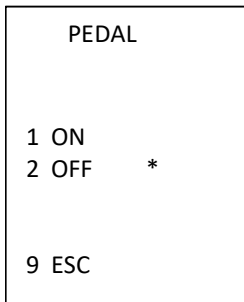

Beeper

By this page, if is installed the optional warning buzzer, it's possible to set the motion alarm, after having inserted the relevant password "8365".

The motion alarm is activated depending on the BEEPER menu setting.

If it's selected ALL the warning buzzer is activated at all the machine movements, both aerial part and ground part.

If it's selected FALL the warning buzzer is activated at the aerial part lowering moment and telescope retraction.

If it's selected WARN the warning buzzer is activated in the same condition or the remote control beeper.

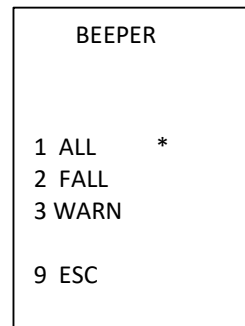

Second Speed

By this page it's possible to set the second speed (Hare), after having inserted the relevant password "5216", pressing button n.1 "ON" second speed will be activated, pressing button n.2 "OFF" second speed will be deactivated.

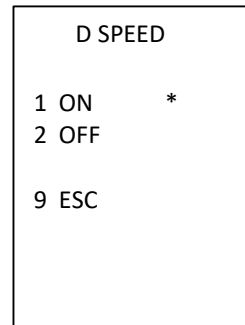

Electric Motor

By this page it's possible to set the electric motor power setting, after having inserted the relevant password "3522", pressing button n.1 "2.2 KW" machine will be set for 2.2 KW electric motor, pressing button n.2 "1.2 KW" it will be set for 1.2 KW electric motor.

The main difference between the two settings is in the auto-stabilization procedure steps timing.

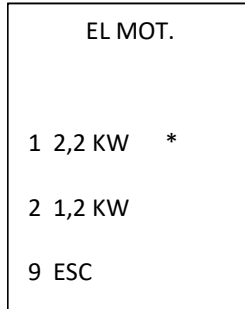

Lamps

By this page it's possible to set the outriggers lights, after having inserted the relevant password "6661", pressing button n.1 "ON" outriggers lights will be steady on while they are touching the ground, pressing button n.2 "FLASH" outriggers lights will be flashing while they are touching the ground.

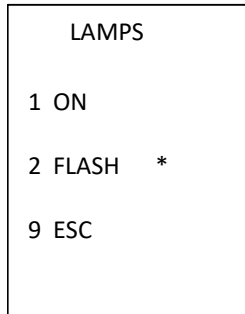

Optional (Page 2)

The here aside picture shows the OPTIONAL menu second page display.

Pressing button n.7 it's possible to come back to the first page of settings.

Pressing button n.9 (ESC) brings back to the EXTRA menu.

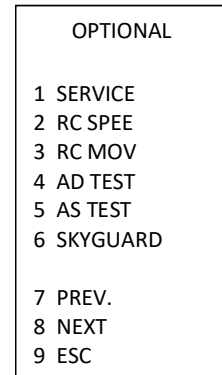

Service

By this page it's possible to set the service reminder, after having inserted the relevant password "4538", pressing button n.1 "ON" service reminder will be activated, pressing button n.2 "OFF" it will be deactivated.

The amount of hours considered is the sum of engine and electric motor ones.

Pressing button n.3 "RESET" those hours counter is reset, keeping pressed button n.5 with buttons n.7 and n.8 it is modified. Instead keeping pressed button n.6 with buttons n.7 and n.8 is modified the service hours amount.

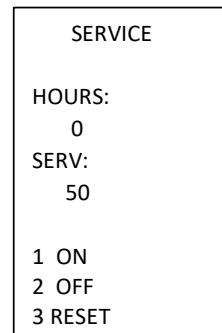

RC Speed

By this page it's possible to set the RC SPEED function, when it is activated it avoids to operate tracks maximum speed when operator is not into the platform.

After having inserted the relevant password "4771", pressing button n.1 "ON" second speed will be activated, pressing button n.2 "OFF" it will be deactivated.

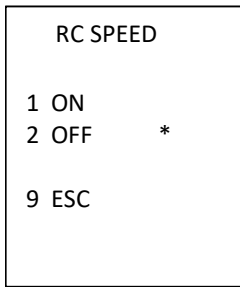

RC Move

By this page it's possible to set the RC MOVE function, when it is activated it binds the operator standing out from the platform to press button n.8 to move tracks

After having inserted the relevant password "4771", pressing button n.1 "ON" second speed will be activated, pressing button n.2 "OFF" it will be deactivated.

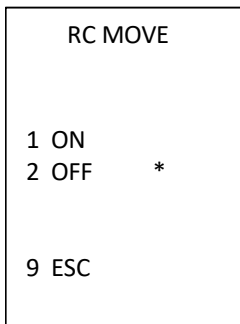

AD Test

Not consider.

AS Test

Not consider.

Skyguard

By this page it's possible to set the Skyguard function, when it is activated, by pressing on Skyguard bar it stops certain movements.

After having inserted the relevant password "4771", pressing button n.1 "ON" and restarting by the main key it will be activated, pressing button n.2 "OFF" and restarting by the main key it will be deactivated.

"REBOOT" indication means that the machine has to be restarted by the main key to activate the function.

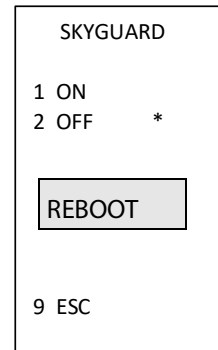

Optional (Page 3)

The here aside picture shows the OPTIONAL menu third page display.

Pressing button n.7 it's possible to come back to the second page of settings.

Pressing button n.9 (ESC) brings back to the EXTRA menu.

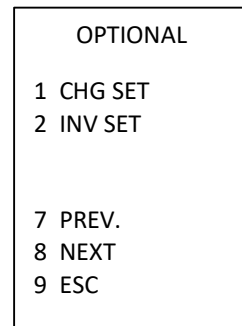

CHG Set

For a lithium machine, by this page it's possible to set the maximum charging current, after having inserted the relevant password "1138", pressing button n.1 it will be settled 25 Amp, pressing button n.2 it will be settled 18 Amp.

This setting, considering the transformation rate, has to respect the maximum current available on local electric plug.

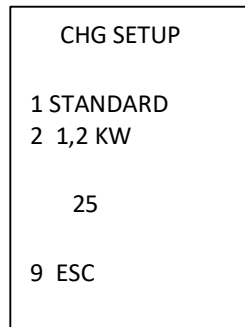
**INV Set**

For a lithium machine, by this page it's possible to setup the rpm setting for a new inverter, pressing button n.1 the rpm setting will be settled according to the machine model settled by the relevant menu, check chapter 10.1.9.2.

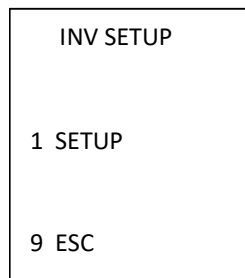

NOTE: Some pages are not accessible, or could not show same information, if not after having inserted the relevant password.

6.5 MASTER BOARD (ECM1) REPLACEMENT AND SETTING

Machine software contains the software for all the TTC JLG machine models produced till that moment, so that when a new master board (ECM1) is installed on a machine, the machine model need to be selected.

New Master Board

When a new master board (never used) is fitted on the machine, the remote control need to be connected to its ground cable and the control position selected accordingly by the control position selector switch.

Then, turning on the main key, it will require the setting of the machine model and version, as indicated by the here below procedure.

To set the master board, machine must be closed and aligned, it has to be make sure that battery is charged enough or machine need to be plugged to the electric network.

Here follows the calibration procedure:

1. Connect the remote control at its ground cable and select the control position accordingly by the control position selector switch.

CONNECTOR ON
REMOTE
CONTROL THE
GROUND CABLE



2. Turn ON the main key and select the correct machine model with button n.1 (VERSION), the display shows the machine model selected. If it appears "MOD.CODE FAIL!", it means that the machine model selected is not correct, even if that alarm does not appear on the display the machine model selected need to be check.

Here below the example shows on the image A the case of machine model selected is wrong, and on image B the case of machine model selected is the right one.

A

```

VERSION
MODEL:
  LL1570
  ENGINE
  D.RPM
MOD. CODE
  FAIL!
1 VERSION
7 MOTOR
3 SAVE
9 ESC
    
```

**MACHINE MODEL
SELECTED IS WRONG**

B

```

VERSION
MODEL:
  LL1570
  ENGINE
  D.RPM
1 VERSION
7 MOTOR
3 SAVE
9 ESC
    
```

**MACHINE MODEL
SELECTED IS OK**

3. In case of the engine model selected is not correct with button n.7 (MOTOR) select the correct one (for instance "D.RPM" is the diesel Hatz 1B40 and "G.13L" is the gasoline Honda iGX390).
4. Press button n.3 (SAVE) to save the setting.
5. Switch the main key OFF and ON again to restart it.
6. Press and release the remote control emergency button to esc the SAFETY STATE.
7. The display will show "LOAD CAL" and "INCL CAL"; following the procedures of appendixes 2 and 1 calibrate the load cell system and the tilt sensor.
8. Following the relevant procedures set the other settings, as ramps and currents.

PERSONALITY SETTING		
MACHINE	MODEL	ENGINE
X13SJP/X13SJN	LL1370	D.RPM
		B.13I
		LITH.

Already Initialized Master Board

The machine system in some cases, specifically for machine models different on a safety point of view, is able to recognize if the machine model selected is not correct.

This verification is possible because on the load cell board (ECM3) a series of contacts input depends on the machine model.

As soon as another master board, already initialized on another machine, is connected to its connectors, as well as when the contacts on the load cell board (ECM3) have been changed, machine will check if the machine model selected on the master board corresponds to the machine model where it is fitted on.

If the machine model selected on the master board does not correspond to the machine model, the correct machine model must be selected by the VERSION menu.

Software Recovery By Modem

In case of main machine software in the master board software is corrupted or missing, if the modem contains the main machine software it is able to install the software in the master board.

When the modem installs the main machine software on the master board, the first part of the installing process is the erasing of the eventual software on master board, so that the remote control display will show wrong images.

While the installing process is in progress the machine must be left switched on for 10-15 minutes, till the ground green light comes on flashing.

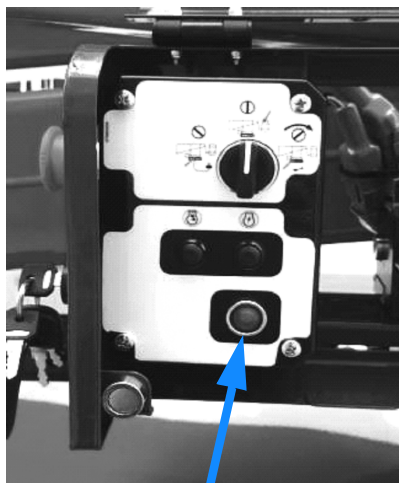

GREEN LIGHT

6.6 CODE MENU

The machine diagnostic system identifies faulty as short circuits and missing connections to the valve coils, further monitoring the circuit load.

For some faulty affecting on aerial part valve coils, which include the gravity emergency descent valves, the summing oil pump valve, the functions could be prevented.

To restart the functions have to turn OFF (ground key OFF) and then ON the machine, as a result all the function are then active with exception the faulty one.

For some faulty affecting on ground part valve coils, which include outrigger movements, track widening, the functions could be prevented.

To restart the functions have to turn OFF (ground key OFF) and then ON the machine, as a result all the function are then active with exception the faulty one.

In case of the display shows the icon FAIL INPUT OUT, as shows here below, it means a faulty issue present on the electric connection.



ELECTRIC CONNECTION ANOMALY IN PROGRESS

NOTE: On X13SJP/X13SJN with fix undercarriage (without tracks widening system), the icon FAIL INPUT OUT could appear also when the tracks widening buttons are pressed.

By the remote control, pressing button 6 - SERVICE and then keeping pressed button 3 - ERR --> COD, it will be displayed the CODE MENU, that is a list of DEVICE with potentially anomalous signal.

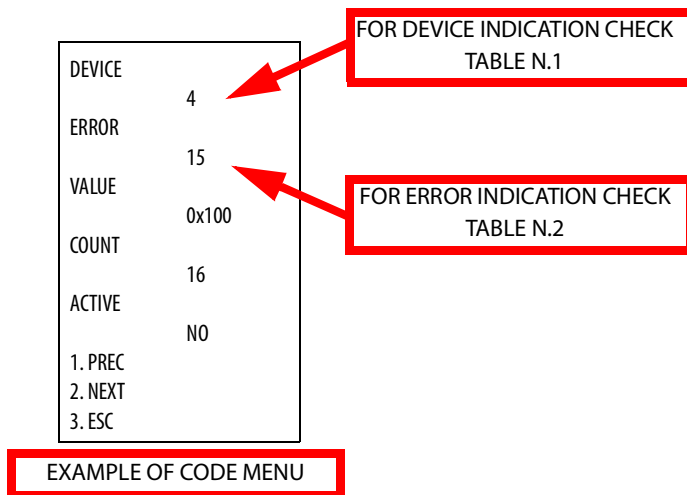

NOTE: By CODE MENU, not all the DEVICES signed with an ERROR and "ACTIVE YES" have to be considered as an anomaly, only in case of the icon FAIL INPUT OUTPUT is displayed there's an anomaly in progress.

Here follows the list of the main DEVICES that could be affected by that kind of anomalies, not all the DEVICES are listed.

Table 6-1. DEVICES

DEVICE CODE	DEVICE DESCRIPTION
22	Ground part right side proportional valve coil
23	Ground part left side proportional valve coil
24	Right track forward valve coil
25	Left track forward valve coil
26	Right track backward valve coil
27	Left track backward valve coil
28	Outrigger n.1 lowering valve coil
29	Outrigger n.2 lowering valve coil
30	Outrigger n.3 lowering valve coil
31	Outrigger n.4 lowering valve coil
32	Outrigger n.1 lifting valve coil
33	Outrigger n.2 lifting valve coil
34	Outrigger n.3 lifting valve coil
35	Outrigger n.4 lifting valve coil
36	1-2 booms lifting valve coil
37	3 boom lifting valve coil
38	1-2 booms lowering valve coil
39	3 boom lowering valve coil
40	Telescope extraction valve coil
41	Telescope retraction valve coil

Table 6-1. DEVICES

DEVICE CODE	DEVICE DESCRIPTION
42	Jib opening valve coil
43	Jib closing valve coil
44	Platform levelling up valve coil
45	Platform levelling down valve coil
46	Turntable right rotation valve coil
47	Turntable left rotation valve coil
48	Platform right rotation valve coil
49	Platform left rotation valve coil
50	Aerial part proportional valve coil
51	Pumps sum valve coil
52	Tracks second speed valve coil
53	Tracks widening valve coil
54	Tracks closing valve coil
55	1-2 booms gravity descent valve coil
56	3 boom gravity descent valve coil
57	Deviator (aerial part/ground part) valve coil

NOTE: On X13SJP the DEVICES 48 and 49 are marked with error 7 because the platform rotation is not available. On LL13.70 with fix undercarriage (without tracks widening system), the DEVICES 53 and 54 are

marked with error 2 because the track widening is not available.

Here follows the list of the main ERRORS, not all the ERRORS are listed.

Table 6-2. ERRORS

ERROR CODE	ERROR DESCRIPTION
0	No error
1	Initialization error
2	Open load error (charge disconnected)
3	Open load error (short circuit)
4	Short circuit to ground
5	Short circuit to battery plus
7	Safety deactivation
8	Out of range error
9	Timeout error
12	Reading error
14	Selection error
15	Occupied
16	Default value not valid

SECTION 6 - JLG CONTROL SYSTEM

EXAMPLES

Here follow some examples of what could be displayed on CODE menu.

EXAMPLE OF A CODE MENU INDICATION WITH NO ERROR IN PROGRESS

STOWED MACHINE WITH NO ERROR		
DEVICE CODE	ERROR CODE	ACTIVE
11	12	NO
12	9	YES
64	2	YES
65	9	NO
66	9	NO
67	4	YES
73	2	NO
89	12	YES
133	1	YES
145	2	YES
154	8	NO
155	8	NO
166	9	YES

NOTE: Some different indications on CODE menu could occur depending on the machine conditions (stabilized, aligned, etc.).

EXAMPLE OF MACHINE WITH A COIL CONNECTION ERROR

In case of the coil of the ON-OFF valve for third boom lifting is disconnected from its cabling or in case of its cable is ripped, when pushing one of the black joysticks, the aerial

part movement will not be carried out and the icon FAIL INPUT OUTPUT will be displayed.

On this case on the CODE MENU at the DEVICE 37 the ERROR 2 (Open load error) or ERROR 5 (Short circuit to battery plus), will be displayed as "ACTIVE YES", while some other DEVICE between the 36 and the 56 will be displayed with ERROR 7 (Safety deactivation).

COIL CONNECTION ERROR EXAMPLE			
DEVICE CODE	ERROR CODE	ACTIVE	
12	9	YES	
36	7	YES	1-2 booms lifting valve coil
<u>37</u>	<u>5</u>	YES	<u>3 boom lifting valve coil</u>
38	7	YES	1-2 booms lowering valve coil
39	7	YES	3 boom lowering valve coil
40	7	YES	Telescope extraction valve coil
41	7	YES	Telescope retraction valve coil
42	7	YES	Jib opening valve coil
43	7	YES	Jib closing valve coil
44	7	YES	Platform levelling up valve coil
45	7	YES	Platform levelling down valve coil
46	7	YES	Turntable right rotation valve coil
47	7	YES	Turntable left rotation valve coil
48	7	YES	Platform right rotation valve coil
49	7	YES	Platform left rotation valve coil
64	2	YES	
65	9	NO	
66	9	NO	

COIL CONNECTION ERROR EXAMPLE		
DEVICE CODE	ERROR CODE	ACTIVE
67	4	YES
73	2	NO
89	12	YES
133	1	YES
145	2	YES
154	8	NO
155	8	NO

EXAMPLE OF MACHINE WITH A COIL CONNECTION ERROR AFTER KEY RESET

From the software release 2.0, resetting the machine by the main key the aerial part movements will be re-acti-

vated, except for the third boom lowering that will be re-activated only after its coil anomaly is restored.

COIL CONNECTION ERROR AFTER KEY RESET EXAMPLE		
DEVICE CODE	ERROR CODE	ACTIVE
12	9	YES
37	2	YES
64	2	YES
65	9	NO
66	9	NO
67	4	YES
73	2	NO
89	12	YES
133	1	YES
145	2	YES
154	8	NO
155	8	NO

3 boom lifting valve coil

SECTION 7. GENERAL ELECTRICAL INFORMATION & SCHEMATICS

7.1 GENERAL

This section contains schematics to be used for locating and correcting most of the operating problems which may develop. If a problem should develop which is not presented in this section or which is not corrected by listed corrective actions, technically qualified guidance should be obtained before proceeding with any maintenance.

NOTICE

IT IS A GOOD PRACTICE TO AVOID PRESSURE-WASHING ELECTRICAL/ELECTRONIC COMPONENTS. SHOULD PRESSURE-WASHING BE UTILIZED TO WASH AREAS CONTAINING ELECTRICAL/ELECTRONIC COMPONENTS, JLG INDUSTRIES, INC. RECOMMENDS A MAXIMUM PRESSURE OF 750 PSI (52 BAR) AT A MINIMUM DISTANCE OF 12 INCHES (30.5 CM) AWAY FROM THESE COMPONENTS. IF ELECTRICAL/ELECTRONIC COMPONENTS ARE SPRAYED, SPRAYING MUST NOT BE DIRECT AND BE FOR BRIEF TIME PERIODS TO AVOID HEAVY SATURATION.

7.2 MULTIMETER BASICS

A wide variety of multimeters or Volt Ohm Meters (VOM) can be used for troubleshooting your equipment. A digital meter with reasonable accuracy (within 7%) is recommended for the measurements in these procedures. This section shows diagrams of a common, digital VOM configured for several different circuit measurements. Instructions for your VOM may vary. Please consult the meter operator's manual for more information.

Grounding

"Grounding the meter" means to take the black lead (which is connected to the COM (common) or negative port) and touch it to a good path to the negative side of the voltage source.

Backprobing

To "backprobe" means to take the measurement by accessing a connector's contact on the same side as the wires, the back of the connector. Readings can be done while maintaining circuit continuity this way. If the connector is the sealed type, great care must be taken to avoid damaging the seal around the wire. It is best to use probes or probe tips specifically designed for this technique, especially on sealed connectors. Whenever possible insert probes into the side of the connector such that the test also checks both terminals of the connection. It is possible to inspect a connection within a closed connector by backprobing both sides of a connector terminal and measuring resistance. Do this after giving each wire a gentle pull to ensure the wires are still attached to the contact and contacts are seated in the connector.

Min/Max

Use of the "Min/Max" recording feature of some meters can help when taking measurements of intermittent conditions while alone. For example, you can read the voltage applied to a solenoid when it is only operational while a switch, far from the solenoid and meter, is held down.

Polarity

Finding a negative voltage or current reading when expecting a positive reading frequently means the leads are reversed. Check what reading is expected, the location of the signal and that the leads are connected to the device under test correctly. Also check that the lead on the "COM" port goes to the ground or negative side of the signal and the lead on the other port goes to the positive side of the signal.

Scale

M = Mega = 1,000,000 * (Displayed Number)

k = kilo = 1,000 * (Displayed Number)

m = milli = (Displayed Number) / 1,000

μ = micro = (Displayed Number) / 1,000,000

Example: 1.2 k Ω = 1200 Ω

Example: 50 mA = 0.05 A

Voltage Measurement

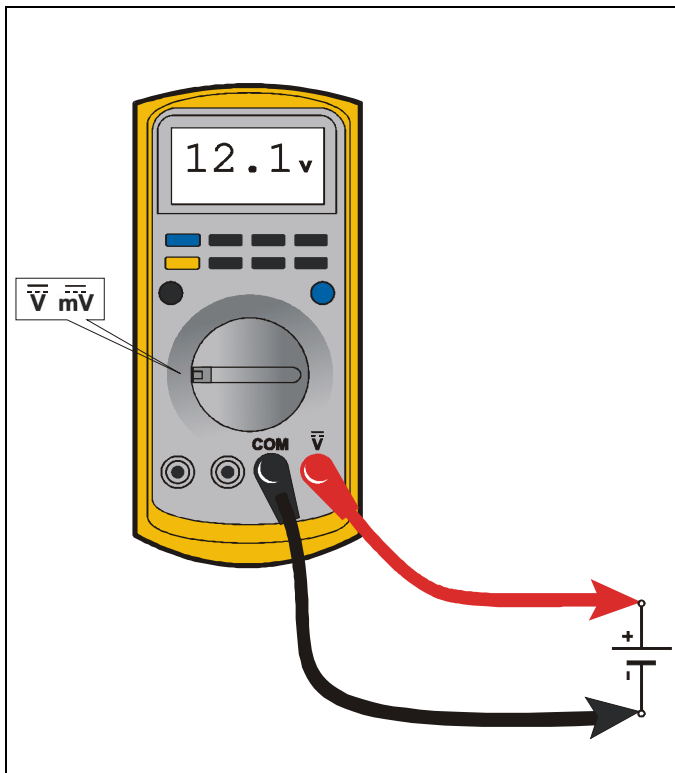

Figure 7-1. Voltage Measurement (DC)

- If meter is not auto ranging, set it to the correct range (See multimeter’s operation manual).
- Use firm contact with meter leads.

Resistance Measurement

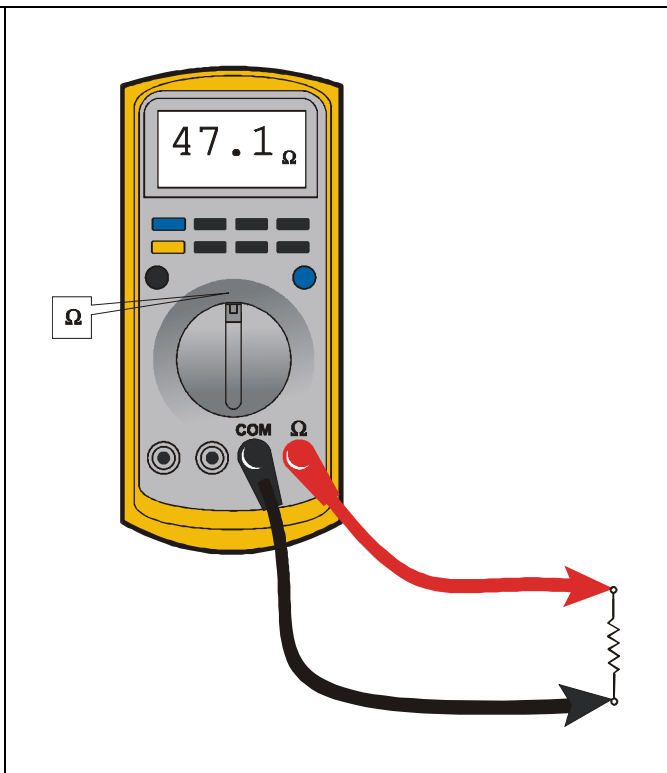
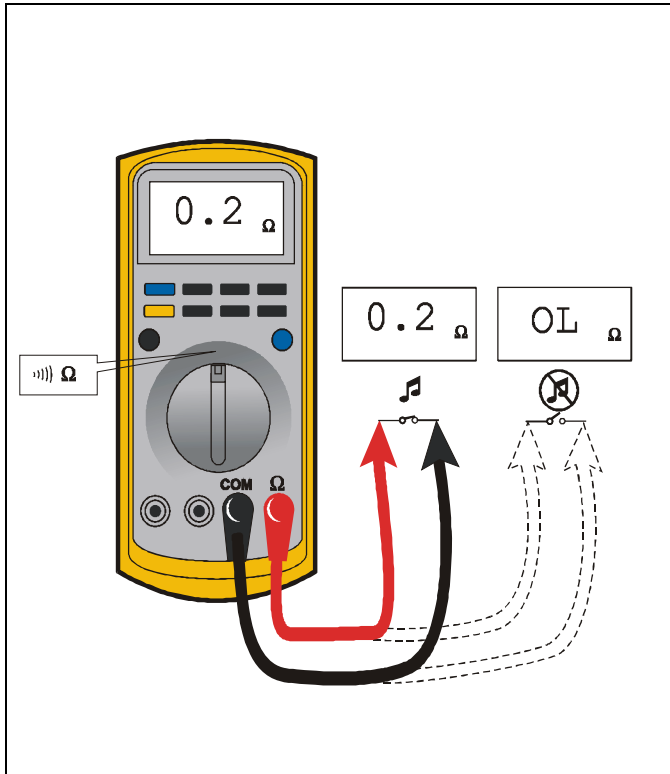
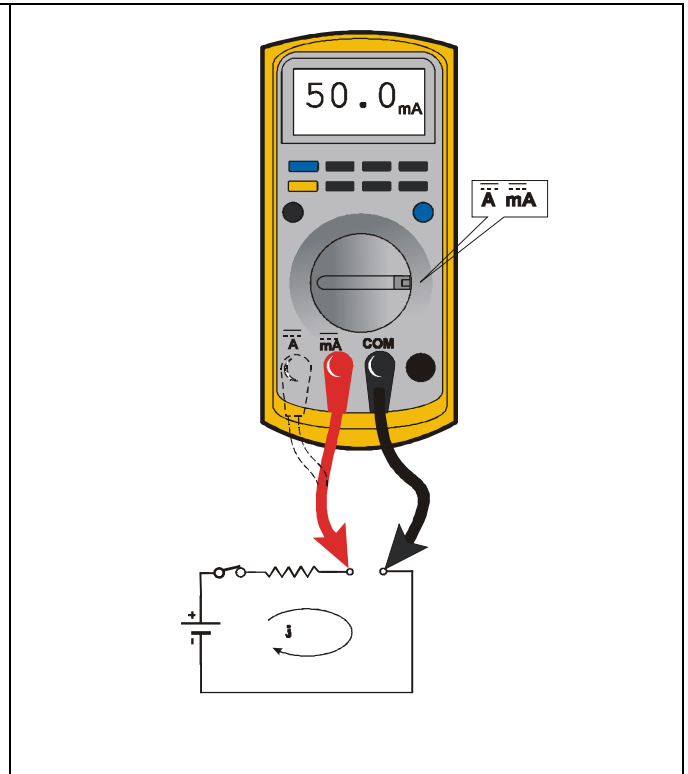

Figure 7-2. Resistance Measurement

- First test meter and leads by touching leads together. Resistance should read a short circuit (very low resistance).
- Circuit power must be turned OFF before testing resistance.
- Disconnect component from circuit before testing.
- If meter is not auto ranging, set it to the correct range (See multimeter’s operation manual).
- Use firm contact with meter leads.

Continuity Measurement**Figure 7-3. Continuity Measurement**

- Some meters require a separate button press to enable audible continuity testing.
- Circuit power must be turned OFF before testing continuity.
- Disconnect component from circuit before testing.
- Use firm contact with meter leads.
- First test meter and leads by touching leads together. Meter should produce an audible alarm, indicating continuity.

Current Measurement**Figure 7-4. Current Measurement (DC)**

- Set up the meter for the expected current range.
- Be sure to connect the meter leads to the correct jacks for the current range you have selected.
- If meter is not auto ranging, set it to the correct range (See multi meter's operation manual).
- Use firm contact with meter leads.

Continuity Measurement Over Long Distances

When trying to determine continuity of a harness or wire, longer than the reach of standard instrument leads, is possible to perform the check without excessively long leads. Using the other wires in the harness one can determine the condition of a particular wire in the harness.

Requirements:

- Harness with at least three separate wires including the wire under test.
- These wires must be able to be isolated from other wires, etc.
- Jumper or method to connect contacts on one side of harness.
- Meter that can measure resistance or continuity.

Procedure

Test multimeter leads resistance. Subtract this value from the measured resistance of the wires to get a more accurate measurement.

Consult the circuit schematic to determine which wires to use in addition to wire under test, here called wire #1 and wire #2, and how to isolate these wires. These wires should appear in the same connectors as the wire under test or are within reach of the jumper.

1. Disconnect all connections associated with the wire under test and the two additional wires. If harness is not completely isolated disconnect battery terminals also, as a precaution.
2. Measure continuity between all three wires, the wire under test, wire #1 and wire #2. These should be open. If not, repair the shorted wires or replace the harness.

3. On one side, jumper from contact of wire #1 and wire #2.
4. Measure continuity between wire #1 and wire #2. If there is continuity, both wires are good and can be used for this test. If there is not continuity, either wire could be bad. Check connections and measurement setup. Redo measurement. If still no continuity, repair wires or consult schematic for other wires to use for test.
5. Jumper from wire under test to wire #1.
6. Measure continuity. If there is continuity, the wire under test is good. Resistance of a wire increases as the length increases and as the diameter decreases.

One can find the continuity of two wires, here #1 and #2, at once by following steps 1 through 4. If there is a problem the third wire is used to troubleshoot the other wires. To find the problem, start at step 1 and use the entire procedure.

7.3 ELECTRICAL SCHEMATICS MANUALS

The electrical schematics manuals are separate from this manual. They are available online (Online Express or www.jlg.com - Manuals) in the same folder where this Service Manual was found.

Here is a listing of the schematic manuals available:

X13SJP, X13SJN.....31222021



An Oshkosh Corporation Company

Corporate Office
JLG Industries, Inc.
1 JLG Drive
McConnellsburg, PA 17233-9533 USA
☎ (717) 485-5161 (Corporate)
☎ (877) 554-5438 (Customer Support)
☎ (717) 485-6417

Visit our website for JLG Worldwide Locations.
www.jlg.com